TECHNICAL MANUAL

**OPERATOR'S, UNIT, DIRECT SUPPORT AND GENERAL SUPPORT
MAINTENANCE MANUAL FOR**

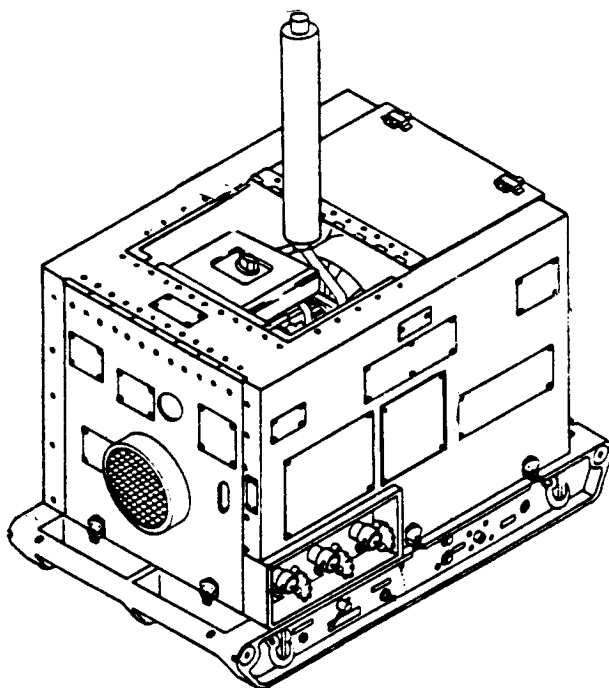

TABLE OF CONTENTS	I
INTRODUCTION	1-1
OPERATING INSTRUCTIONS	2-1
OPERATOR MAINTENANCE	3-1
UNIT MAINTENANCE	4-1
DIRECT SUPPORT MAINTENANCE	5-1
GENERAL SUPPORT MAINTENANCE	6-1

This copy is a reprint which includes current pages from Changes 1 and 2.

**SMALL MOBILE WATER CHILLER
(4130-01-333-6086)**

Approved for public release; distribution is unlimited

* *This manual supersedes Change 4 to TM 5-4130-237-14, dated 17 April 1991.*

**HEADQUARTERS, DEPARTMENT OF THE ARMY
14 November 1991**

CHANGE

NO. 3

HEADQUARTERS
DEPARTMENT OF THE ARMY
WASHINGTON, D.C., 30 SEPTEMBER 1996

Operator's, Unit, Direct Support and General Support
Maintenance Manual

SMALL MOBILE WATER CHILLER
NSN 4130-01-333-6086

DISTRIBUTION STATEMENT A: Approved for public release; distribution is unlimited.

TM 10-4130-239-14, 14 November 1991, is changed as follows:

1. Remove and insert pages as indicated below. New or changed text material is indicated by a vertical bar in the margin. An illustration change is indicated by a miniature pointing hand.

Remove pages
i and ii
4-61 and 4-62

Insert pages
i and ii
4-61 and 4-62

2. Retain this sheet in front of manual for reference purposes.

By Order of the Secretary of the Army:

DENNIS J. REIMER
General, United States Army
Chief of Staff

Official:



JOEL B. HUDSON

Administrative Assistant to the
Secretary of the Army

02607

DISTRIBUTION:

To be distributed in accordance with DA Form 12-25-E, block no. 5428, requirements for TM 10-4130-239-14.

CHANGE

N O . 2

HEADQUARTERS
DEPARTMENT OF THE ARMY
WASHINGTON, D. C., 30 December 1993

Operator's, Unit, Direct Support and General Support
Maintenance Manual

SMALL MOBILE WATER CHILLER
NSN 4130-01-333-0686

DISTRIBUTION STATEMENT A: Approved for public release; distribution is unlimited

TM 10-41 30-239-14, 14 November 1991, is changed as follows:

1. Remove and insert pages as indicated below. New or changed text material is indicated by a vertical bar in the margin. An illustration change is indicated by a miniature pointing hand.

Remove pages

a and b
2-1 1 and 2-12
2-25 and 2-26
4-15 and 4-16
4-53 through 4-58
4-65 and 4-66
4-73 and 4-74
4-105 and 4-106
5-31 and 5-32

Insert pages

a and b
2-1 1 and 2-12
2-25 and 2-26
4-15 and 4-16
4-53 through 4-58
4-65 and 4-66
4-73 and 4-74
4-105 and 4-106
5-31 and 5-32

2. Retain this sheet in front of manual for reference purposes.

By Order of the Secretary of the Army:

Official:

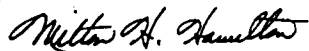

MILTON H. HAMILTON
*Administrative Assistant to the
Secretary of the Army*

05991

GORDON R. SULLIVAN
*General, United States Army
Chief of Staff*

DISTRIBUTION:

To be distributed in accordance with DA Form 12-25-E, block no. 5428, requirements for
TM 10-4130-239-14.

CHANGE

NO. 1

HEADQUARTERS
DEPARTMENT OF THE ARMY
WASHINGTON, D.C., 1 JULY 1992

Operator's, Unit, Direct Support and General Support
Maintenance Manual

SMALL MOBILE WATER CHILLER
NSN 4130-01-333-6086

Approved for public release; Distribution is unlimited

TM 5-4130-239-14, 14 November 1991 is changed as follows:

1. Remove and insert pages as indicated below. New or changed text material is indicated by a vertical bar in the margin. An illustration change is indicated by a miniature pointing hand.

Remove pages

5-3 through 5-6
5-17 and 5-18
B-9 and B-10

Insert pages

5-3 through 5-6
5-17 and 5-18
B-9 and B-10

2. Retain this sheet in front of manual for reference purposes.

By Order of the Secretary of the Army:

Official:

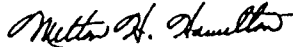

MILTON H. HAMILTON
*Administrative Assistant to the
Secretary of the Army*

01617

GORDON R. SULLIVAN
*General, United States Army
Chief of Staff*

DISTRIBUTION:

To be distributed in accordance with DA Form 12-25E, (qty rqr block no. 2347).

WARNINGS

To prevent electrical shock, make sure power is disconnected from 12 VOLT INPUT FOR STARTING connection before performing this procedure. ■

Solvent may cause toxic fumes. To prevent personal injury, work only in well ventilated area. DO NOT breathe fumes for a long time.

Nitrogen is an inert gas. However, it also presents the danger of suffocation and therefore, must also be discharged in a ventilated location.

When the refrigeration system must be opened for any reason, carefully discharge the refrigerant first. Avoid contact with liquid refrigerant. Severe freezing of body tissues can take place with extreme rapidity. Avoid excessive inhalation of refrigerant gas, and ventilate the area in which it is released.

Refrigerant gas in contact with flame or hot surfaces is converted to phosgene. Phosgene is a highly toxic gas with an odor similar to newly mown grass or hay.

To prevent damage to hearing, wear hearing protection at all times within 4 feet (1.2 meters) of water chiller.

Fuel is flammable. To prevent fire or explosion, DO NOT bring spark or open flame near fuel line.

Solvent is flammable. To prevent fire or explosion, DO NOT bring spark or open flame near solvent.

Polyurethane foam is flammable. Burning foam causes toxic fumes. When soldering, be very careful not to ignite foam.

Death or serious injury may result if personnel fail to observe safety precautions. Use great care to avoid contact with liquid refrigerant or refrigerant gas discharging under pressure. Sudden and irreversible tissue damage can result from freezing. Wear thermal protective gloves and a face protector or goggles in any situation where skin-eye contact is possible.

FOR FIRST AID, SEE FM 21-11.

WARNINGS

Calcium hypochlorite can cause serious injury if not handled properly. Heed all safety measures below. If calcium hypochlorite comes into contact with skin or eyes, flush right away with water. Get medical help.

Do not operate water chiller after shipment or repairs until system has been purged with disinfectant to prevent water contamination. (See paragraph 2-8a.)

All refrigerant must be discharged from the system and the entire system must be purged with dry nitrogen before beginning any debrazing operation.

Nitrogen cylinders are pressurized containers. The pressure in the cylinder can exceed 2000 psi. A nitrogen pressure regulator should be used at all times when nitrogen is used for leak check or purge operations.

To prevent burns, DO NOT try to remove muffler until it cools down.

To prevent personal injury, four persons required to lift.

FOR FIRST AID, SEE FM 21-11.

**Operator's, Unit, Direct Support and General
Support Maintenance Manual
FOR
SMALL MOBILE WATER CHILLER
(4130-01-333-6086)**

REPORTING ERRORS AND RECOMMENDING IMPROVEMENTS

You can help improve this manual. If you find any mistakes, or if you know of a way to improve these procedures, please let us know. Mail your letter or DA Form 2028 (Recommended Changes to Publications and Blank Forms), or DA Form 2028-2 located in the back of this manual directly to: Commander, US Army Aviation and Troop Command, ATTN: AMSAT-I-MP, 4300 Goodfellow Blvd., St. Louis, MO 63120-1798. You may also submit your recommended changes by E-mail directly to <mpmt%avma28@st-louis-emh7.army.mil>. A reply will be furnished directly to you. Instructions for sending an electronic 2028 may be found at the back of this manual immediately preceding the hard copy 2028.

DISTRIBUTION STATEMENT A: Approved for public release; distribution is unlimited.

	Page
How to Use This Manual	iii
I CHAPTER 1 INTRODUCTION I	1-1
Section I General Information	1-1
Section II Equipment Description and Data1-2	
Section III Principles of Operation.....	1-6
CHAPTER 2 OPERATING INSTRUCTIONS I	2-1
Section I Description and Use of Operator's Controls and Indicators.....	2-1
Section II Operator Preventive Maintenance Checks and Services (PMCS)	2-3
Section III Operation Under Usual Conditions	2-16
Section IV Operation Under Unusual Conditions	2-31
CHAPTER 3 OPERATOR MAINTENANCE INSTRUCTIONS I	3-1
Section I Lubrication Instructions.....	3-1
Section II Troubleshooting Procedures.....	3-1
Section III Operator's Maintenance Procedures	3-3

* This manual supersedes Change 4 to TM 5-4130-237-14, dated 17April 1991.

	Page
CHAPTER 4 UNIT MAINTENANCE INSTRUCTIONS	4-1
Section I Lubrication Instructions	4-1
Section II Repair Parts; Special Tools; Test, Measure- ment, and Diagnostic Equipment (TMDE); and Support Equipment	4-2
Section III Service Upon Receipt	4-2
Section IV Unit Preventive Maintenance and Services (PMCS)	4-8
Section V Unit Troubleshooting	4-14
Section VI Maintenance Procedures	4-19
Section VII Preparation for Storage or Shipment	4-104
CHAPTER 5 DIRECT SUPPORT MAINTENANCE	5-1
Section I Troubleshooting	5-1
Section II General Maintenance Procedures	5-3
Section III Maintenance Procedures	5-19
CHAPTER 6 GENERAL SUPPORT MAINTENANCE	6-1
APPENDIX A REFERENCES	A-1
APPENDIX B MAINTENANCE ALLOCATION CHART	B-1
APPENDIX C COMPONENTS OF END ITEM AND BASIC ISSUE ITEMS LISTS	C-1
APPENDIX D ADDITIONAL AUTHORIZATION LIST	D-1
APPENDIX E EXPENDABLE/DURABLE SUPPLIES AND MATERIALS LIST	E-1
APPENDIX F ILLUSTRATED LIST OF MANUFACTURED ITEMS	F-1
INDEX	Index-1

HOW TO USE THIS MANUAL

This manual is designed to help you operate and maintain the Small Mobile Water Chiller. The front cover table of contents is provided for quick reference to important information. There is also an index located in the final pages for use in locating specific items of information.

Measurements in the manual are given in both US standard and metric units. A metric to US standard conversion chart can be found on the inside back cover.

Read all preliminary information found at the beginning of each task. It has important information and safety instructions you must follow before beginning the task.

Warning pages are located in the front of this manual. You should read the warnings before operating or doing maintenance on the equipment.

A subject index appears at the beginning of each chapter listing sections that are included in that chapter. A more specific index is located at the beginning of each section to help you find the exact paragraph you're looking for.

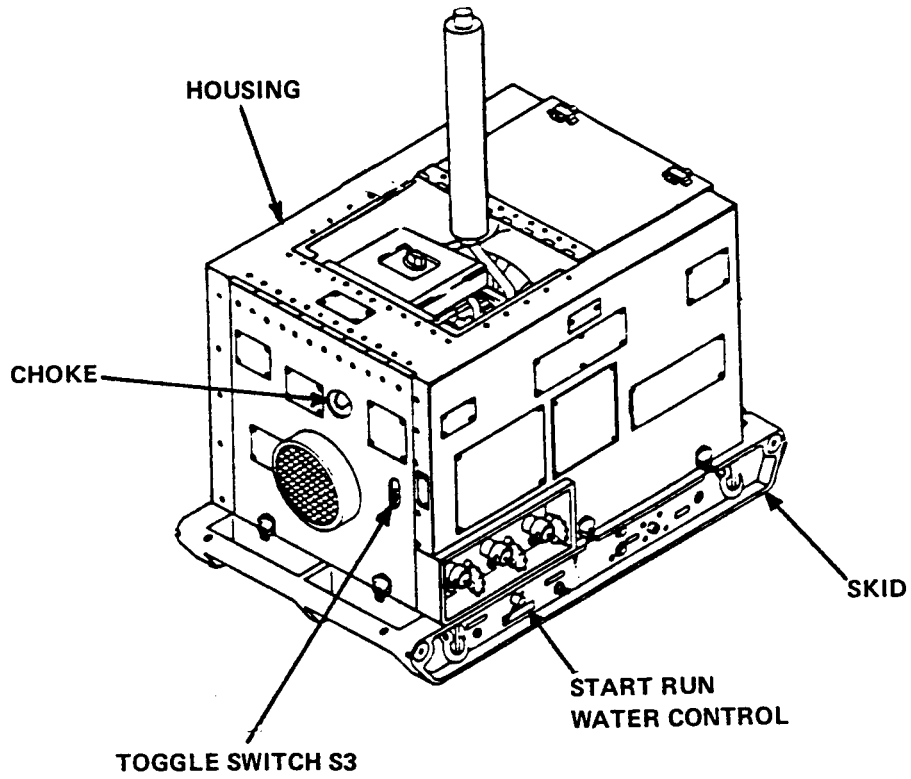

CHAPTER 1

INTRODUCTION

INDEX

SECTION	TITLE	PAGE
I.	GENERAL INFORMATION	1-1
II.	EQUIPMENT DESCRIPTION AND DATA	1-2
III.	PRINCIPLES OF OPERATION	1-6

Section I. GENERAL INFORMATION

1-1. SCOPE.

a. Type of Manual: Operator's, Unit, Direct and General Support Maintenance.

b. Model Number and Equipment Name: Airtacs model A-WC40-G/E, Small Mobile Water Chiller, 40 GPH at 70 Degrees with Support Kit and Trailer Mounting Kits.

Purpose of Equipment: The water chiller cools intake water to 60°F (16°C) and delivers it at 40 gallons (151 liters) per hour.

1-2. MAINTENANCE FORMS, RECORDS AND REPORTS. Department of the Army forms and procedures used for equipment maintenance will be those prescribed by DA PAM 738-750, The Army Maintenance Management System (TAMMS) .

1-3. DESTRUCTION OF ARMY MATERIAL TO PREVENT ENEMY USE. Refer to TM-750-244-3, Procedures for Destruction of Equipment to Prevent Enemy Use, for information about destruction.

1-4. PREPARATION FOR STORAGE OR SHIPMENT.

a. Placement of equipment in administrative storage should be for short periods of time when a shortage of maintenance effort exists. Items should be in mission readiness within 24 hours or within the time factors as determined by the directing authority. During the storage period appropriate maintenance records will be kept.

b. Before placing equipment in administrative storage, next scheduled maintenance service should be completed, shortcomings and deficiencies should be corrected, and all Modification Work Orders (MWO'S) should be applied.

1-4. PREPARATION FOR STORAGE OR SHIPMENT (CONT)

c. Storage site selection. Inside storage is preferred for items selected for administrative storage. If inside storage is not available, trucks, vans, conex containers and other containers may be used.

1-5. REPORTING EQUIPMENT IMPROVEMENT RECOMMENDATIONS (EIR). If your water chiller needs improvement, let us know. Send us an EIR. You, the user, are the only one who can tell us what you do not like about your equipment. Let us know why you do not like the design. Tell us why you don't like the design or performance. Put it on a SF 368 (Quality Deficiency Report). Mail it to us at: Command, U.S. Army Troop Support Command, ATTN: AMSTR-MOF, 4300 Goodfellow Boulevard, St. Louis, MO 63120-1798. We'll send you a reply:

1-6. LIST OF ABBREVIATIONS.

BTU/HR	British Thermal Units per Hour
C	Celsius
CC	cubic centimeters
F	Fahrenheit
gph	gallons per hour
gpm	gallons per minute
Hg	mercury
hp	horsepower
in	inch
kg	kilogram
kg/m ²	kilogram per square meter
kg/cm ²	kilogram per square centimeter
Kpm	Kilograms per meter
l	liter
lb	pound
ml	millimeters
Nu	Newton meters
OD	outside dimension
psi	pounds force per square inch
psig	pounds force per square inch gauge
pt	pint
rpm	revolutions per minute
V	volts
VDC	Volts Direct Current

Section II. EQUIPMENT DESCRIPTION AND DATA

1-7. EQUIPMENT CHARACTERISTICS, CAPABILITIES, AND FEATURES.

a. Characteristics.

- 1 Powered by an air-cooled, gasoline-driven engine.
- 2 Used on M149 series trailers.

1-7. **EQUIPMENT CHARACTERISTICS, CAPABILITIES, AND FEATURES (CONT)**

3 Compatible with 400-gallon (1514 liter) water trailer, 250-gallon (946 liter) and 500-gallon (1893 liter) fabric drums, and 5-gallon (19 liter) cans.

b. Capabilities and Features.

1 Cools intake water of 120° F (49°C) to about 60°F (16°).

2 Delivers water at a rate of 40-gallons (151 liters) per hour.

3 Skid-mounted for ease of transport; four-man portable for short distance.

4 Started with either rope or with 12 volt power source.

1-8. **LOCATION AND DESCRIPTION OF MAJOR COMPONENTS.**

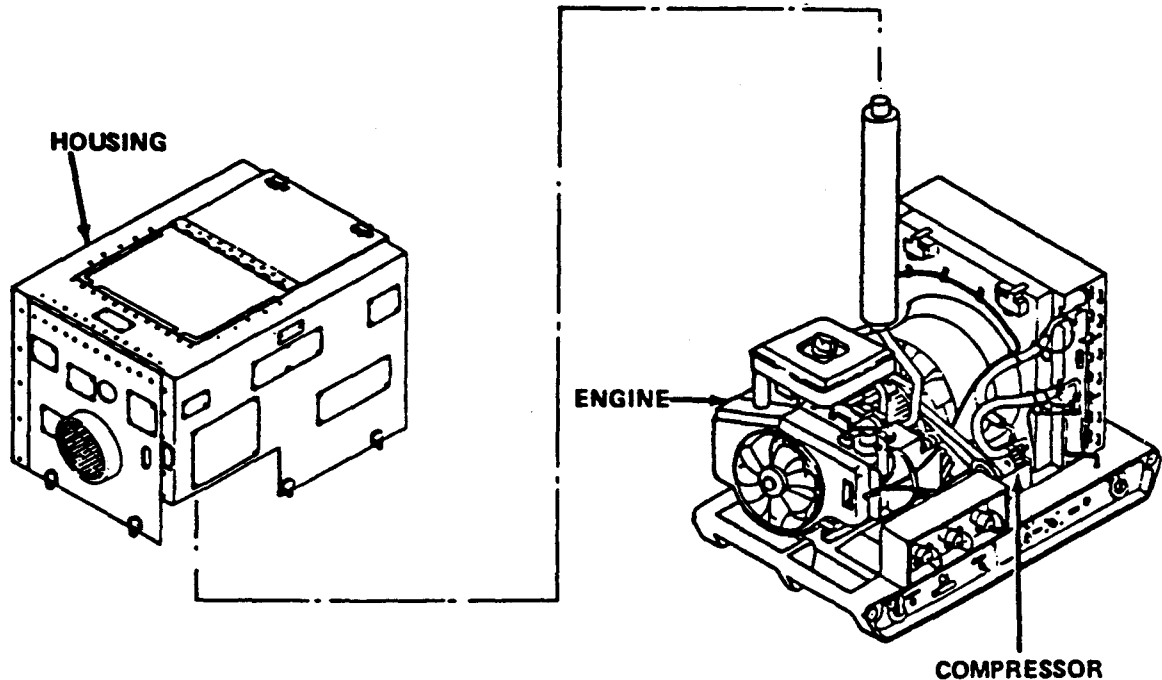

HOUSING. Protects water chiller from damage. Covers moving parts.

ENGINE . Powers belts which drive the compressor and water pump.

COMPRESSOR. Compresses and circulates refrigerant.

1-8. LOCATION AND DESCRIPTION OF MAJOR COMPONENTS (CONT)

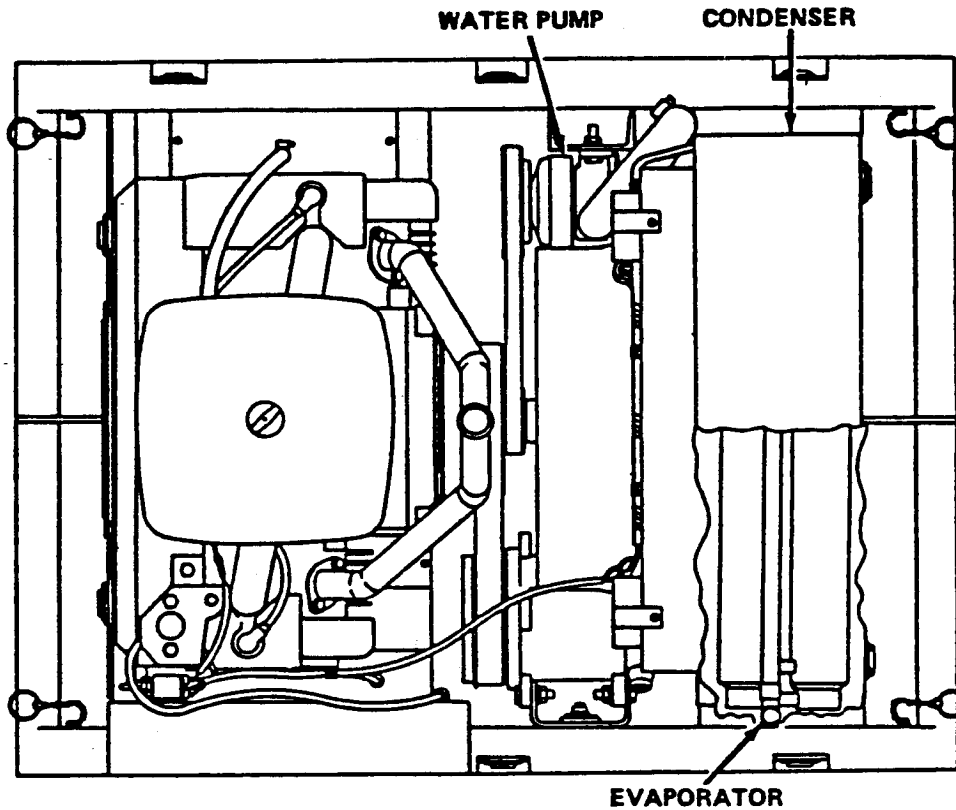

CONDENSER. Changes gas refrigerant to liquid.

WATER PUMP. Pumps water through evaporator.

EVAPORATOR . Absorbs heat from water.

1-9. **EQUIPMENT DATA.** The following listing contains the performance and dimensional data relating to unit maintenance functions.

Water Chiller

Height, cover.	20 in (51 cm)
Width cover.	25 in (64 cm)
Length, cover.	29 in (74 cm)
Height, overall.	24 in (61 cm)
Width, overall.	26 in (66 cm)
Length, overall.	34 in (86 cm)
Gross weight.315 lb (143 kg)
Operating range	
Temperature in:60°F (16°C) to 120°F (49°C)
Temperature out:	50°F (10°C) to 70°F (21°C)
Capacity	0.7 gpm +/- 0.3 gpm at 120°F (49°C) inlet water

1-9. EQUIPMENT DATA (CONT)

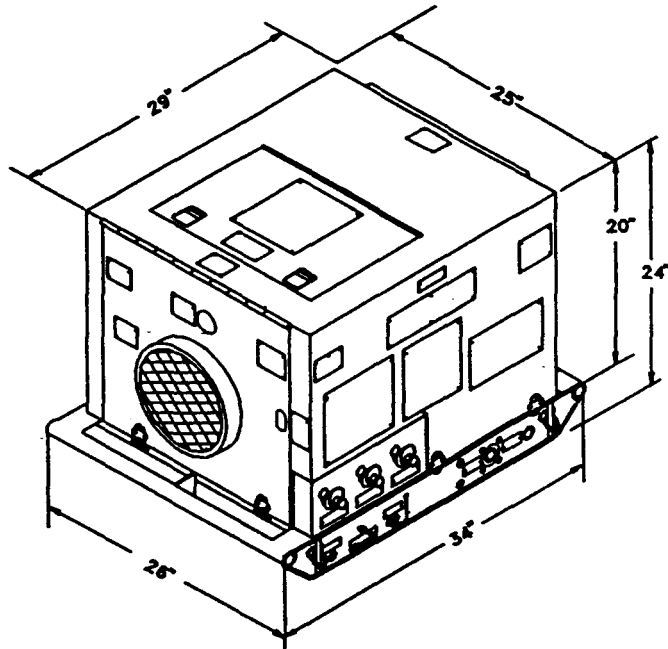

Gasoline Engine

Manufacture.	Briggs & Stratton
Type.	2 cylinder
Cycles.	4
Model.422435
Type.1199
Code.01
Horsepower.18 @ 3600 RPM
Torque.28.6 ft. lbs @ 2600 RPM
Engine speed (no load).	2700 RPM
Bore.3.44 in. (8.74cm)
Stroke.	2.16in. (5.49 cm)
Displacement.42.33 in. (688 cm ³)
Ignition.	Electronic Inductive Storage
Spark plug gap (resistor type).0.030 (0.76 mm)
Crankcase oil capacity.	3.0 pt (1.4 l)
Weight.106 lb (48 kg)

Refrigerant System

Amount of refrigerant	3.75 lb (1.6 kg)
Type of refrigerant	R-12
Compressor (model).	SD-507
Manufacture.	Sanko
Compressor (oil charge)	5.5 oz (198 g)
Weight.9 lb (4.0 kg)
Expansion valve super heat setting.	12°F +/- 1°F
Relief valve pressure setting325 psig (2,241 Nm)

1-9. EQUIPMENT DATA (CONT)

Refrigerant System (cont)

High pressure switch setting . . .286-304 psig (1,972-2,096 kN/M²)
Low pressure switch setting 24 psig (165 kN/M²)

Kits

Support kit
Gross weight 47 lb (21 kg)
Trailer mounting kit
Gross weight 69 lb (31 kg)

See Appendix C located at end of manual for listing of contents of each kit.

Shipping Container

Length. 41 in (104 cm)
Width.32 in(81 cm)
Height. 44 in (112 cm)
Approximate shipping weight. 679 lb (308 kg)

Section III. PRINCIPLES OF OPERATION

1-10. GENERAL OPERATION. The water chiller consists of three major components. A gasoline engine, a refrigerant system, and a water system.

a. The gasoline engine powers the refrigerant compressor (B1) and water pump (P1). A centrifugal clutch on the engine drive shaft will allow the engine to start up and gain speed with a load or run even if the refrigerant compressor locks-up. To simplify starting the engine with the rope starter, a pneumatic timer switch (S8) is incorporated. This will allow pulling the rope without having to hold the starter switch (S3) at the same time. The engine speed is preset and governor controlled.

b. The refrigerant system transfers heat absorbed in the evaporator (E1) and discharges that heat to the condenser coil (C1). Pressure switches (S1 and S2) prevent damage to components in the event of failures.

c. Warm water flows into the water chiller through a hose. In the initial starting phase, water is by-passed around the thermostatic blending valve (V4) by the "START-RUN" water control valve (V5). Once the engine is up to speed, the "START-RUN" valve is turned and water is run through the thermostatic valve. The valve will automatically either recirculate the water to reduce the temperature, or will open and allow more warm water into the system. Cool water will be available within three minutes of starting at the dispense nozzle. Water that is not dispensed will be returned to the water tank

1-10. GENERAL OPERATION (CONT)

mounted on the trailer. A small heat exchanger (E2) is used to cool the fuel to prevent vapor lock in high ambient situations. If water fails to flow or the water is cooled to a preset temperature in the tank, a sensor will shut-down the engine.

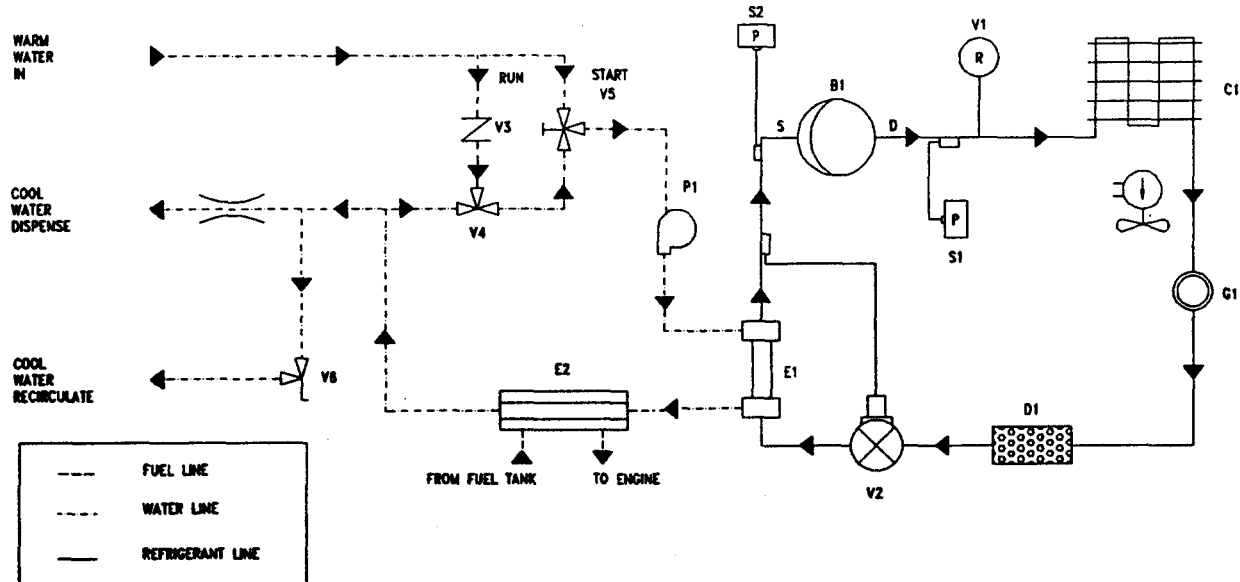

1 MAJOR SYSTEMS

(a) Water System

- (1) Water storage container (not furnished). The water storage container is a source of treated potable water and is connected by flexible hose to the water chiller for cooling.
- (2) Start run valve. The start run valve directs the flow of water from the storage container. To start the engine the start run valve must be in the start position. In this position the water by-passes the blending valve. After a few minutes turn the start run valve to the run position. Water is now circulated through the blending valve.
- (3) Blending valve. The thermostatically controlled blending valve controls the flow of water for tempering warm water from the storage container with cool water from the evaporator to provide a constant load to the evaporator heat exchanger inlet.
- (4) Water pump. The water pump circulates the potable water through the evaporator jacket for cooling or through the blending valve for recirculating as

1-10. GENERAL OPERATION (CONT)

required by the thermostatically controlled blending valve.

- (5) Heat exchanger. The heat exchanger is used to cool the fuel before

(b) Power System

- (1) Engine. The water chiller engine is of the same basic 4 stroke cycle design used in automobiles, trucks and tractors. As the name indicates, there are four strokes to one complete power cycle, intake compression, power, and exhaust.
- (2) Starter. The starter motor uses a gear type engagement method, similar to an automobile starter. The starter motor shaft drives a pinion gear into engagement with a ring gear attached to the engine flywheel and cranks the engine.
- (3) Carburetor. The carburetor incorporates an independent high speed fuel circuit and a separate idle speed fuel circuit. An integral vacuum pulse type fuel pump allows remote fuel source. The pump will prime at 18 in. (457 mm) maximum lift.
- (4) Ignition. The ignition system consists of a self-contained transistor module (no moving parts) mounted on the ignition armature, and a flywheel with magnets.
- (5) Governor. The governor spring tends to pull the throttle open. The force of the counter weights, which are operated by centrifugal force, tends to close the throttle. The engine speed at which these two forces balance is called the governed speed.
- (6) Lubrication. Oil has four purposes. It cools, cleans, seals and lubricates. The engine is lubricated with a connecting rod dipper.

(c) Refrigerant System. The major components of the refrigerant system are as follows:

- (1) Compressor. The compressor is used to compress and circulate R-12 refrigerant through the system.
- (2) Condenser Coil. The condenser coil air-cools the compressed gas refrigerant reduces it to a liquid at high pressure.

1-10. GENERAL OPERATION (CONT)

- (3) Fan. The fan draws outside air through the condenser coil to dissipate the heat generated by compressed refrigerant.
- (4) Sight Glass. The sight glass is an inline liquid indicator that provides a visual means of determining the condition of refrigerant flowing through the system as follows:
 - A dark green center indicates no moisture in the refrigerant.
 - A light green center indicates an acceptable moisture content in the refrigerant.
 - A yellow center indicates too much moisture in the refrigerant.
 - Milky white or bubbly liquid indicates a low refrigerant charge.
 - Clear bubble-free refrigerant indicates a fully charged system.
- (5) Expansion Valve. The expansion valve controls expansion of liquid refrigerant to gas.
- (6) Evaporator. The heat exchanger transfers the heat from the water to the refrigerant.
- (7) Automatic Pressure Control Switches. The automatic control switches are provided as high and low pressure control devices for the refrigerant system.
 - a. Low Pressure Switch. The low pressure switch stops the water chiller when the suction line pressure drops to the minimum pressure allowed.
 - b. High Pressure Switch. The high pressure switch stops the water chiller when the allowable maximum working pressure is exceeded.
- (8) Refrigerant Service Ports. The service ports are provided to service the high and low side of the refrigerant system.
- (9) Pressure Relief Valve. The pressure relief valve vents the refrigerant system to the atmosphere when the maximum allowable pressure is exceeded.

CHAPTER 2
OPERATING INSTRUCTIONS

INDEX

SECTION	TITLE	PAGE
I.	DESCRIPTION AND USE OF OPERATOR'S CONTROLS AND INDICATORS	2-1
II.	OPERATOR PREVENTIVE MAINTENANCE CHECKS AND SERVICES	2-3
III.	OPERATION UNDER USUAL CONDITIONS	2-16
IV.	OPERATION UNDER UNUSUAL CONDITIONS	2-31

Section I. DESCRIPTION AND USE OF OPERATOR'S CONTROLS AND INDICATORS

2-1. GENERAL . The water chiller is intended for cooling treated potable water stored in transport tanks and containers. The water chiller draws water from the storage container, reduces the water temperature, and delivers the cooled water at a preselected temperature to a dispenser, storage, or transport container.

2-2. OPERATOR'S CONTROLS AND INDICATORS.

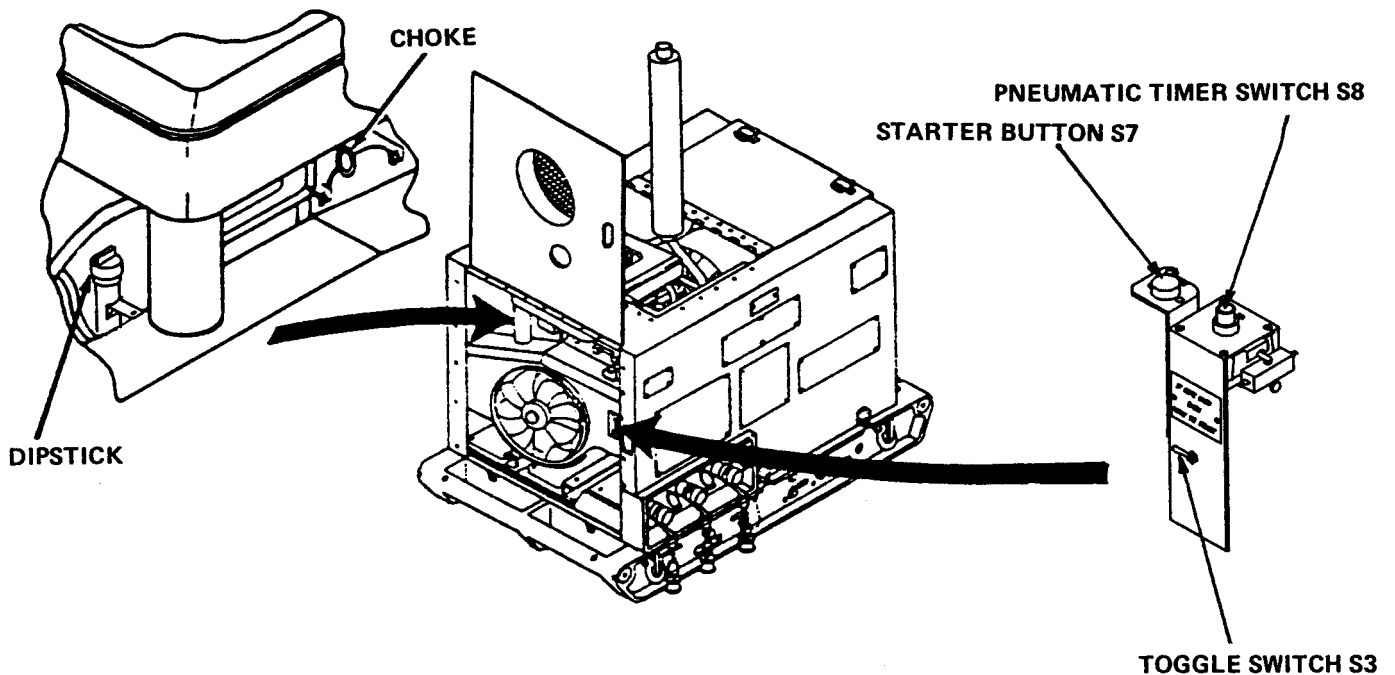

2-2. OPERATOR'S CONTROLS AND INDICATORS (CONT)

Control or Indicator	Function
Dipstick	Used to check oil level.
Choke	Pulled out to engage. Increases gas flow to engine. Push in as engine warms.
Starter Button S7	Engages starter when pressed. Disengages starter when released.
Toggle Switch S3	Used to place equipment in STOP, RUN, or START mode.
Pneumatic Timer Switch S8	Used to start engine when using rope starter.

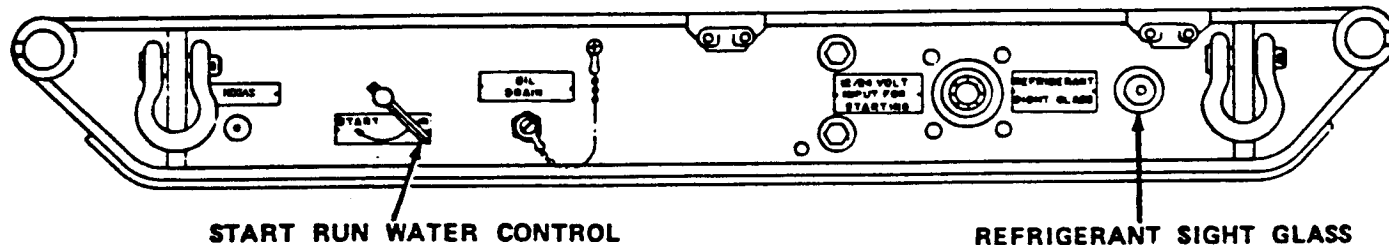

Control or Indicator	Function
START RUN Water Control	Placed in START position for starting and in RUN position for circulating water.
REFRIGERANT SIGHT GLASS	Shows amount of moisture in refrigerant and status of refrigerant charge as follows: Dark green center - no moisture Light green center - acceptable moisture content Yellow center - too much moisture

2-2. OPERATOR'S CONTROLS AND INDICATORS (CONT)

Control or Indicator	Function
REFRIGERANT SIGHT GLASS (Cent)	<p>Milky white or bubbly liquid - low refrigerant charge</p> <p>Clear, bubble-free refrigerant - fully charged system</p>

Section II. OPERATOR PREVENTIVE MAINTENANCE CHECKS AND SERVICES (PMCS)

2-3. GENERAL

a. Before You Operate. Always keep in mind the CAUTIONS and WARNINGS. Perform your before (B) PMCS prior to the equipment performing its intended mission.

b. While You Operate. Always keep in mind the CAUTIONS and WARNINGS. Perform your during (D) PMCS when the equipment is being used in its intended mission.

c. After You Operate. Be sure to perform your after (A) PMCS after the equipment has been taken out of its mission mode or returned to its containment area.

d. If Your Equipment Fails to Operate. Troubleshoot using proper equipment. Report any deficiencies using proper forms. Refer to DA Pam 738-750.

2-4. PMCS PROCEDURES

a. The PMCS table lists the inspections and care of your equipment required to keep it in good operating condition.

b. The Interval column of the PMCS table tells you when to do a certain check or service.

c. The Item to Be Inspected Procedure column of the PMCS table tells you what to inspect and how to do the required checks and services. Carefully follow these instructions.

d. If your equipment does not perform as required, notify unit maintenance. Report any malfunctions or failures on DA Form 2404, or refer to DA Pam 738-750.

e. If the PMCS table requires removal of assemblies or equipment, refer to the maintenance paragraph listed.

2-5. EQUIPMENT IS NOT READY/AVAILABLE IF PROCEDURES. The Equipment Is Not Ready/Available If: column tells you when and why your equipment cannot be used.

NOTE

Both terms "ready/available" and "mission capable" indicate equipment is on hand and is able to perform its combat missions. (See DA Pam 738-750.)

CAUTION

- Equipment operation is allowable with minor leakages (Class I or II). (See note below.) Of course, you must consider the fluid capacity in the item/system being checked/inspected. When in doubt, notify your supervisor.
- When operating with Class I or Class II leaks, continue to check fluid levels as required in your PMCS.
- Class III leaks should be reported to your supervisor or unit maintenance.

NOTE

- Leakage for operator/crew PMCS shall be classified as follows:
 - Class I Seepage of fluid (as indicated by wetness or discoloration) not great enough to form drops.
 - Class II Leakage of fluid great enough to form drops but not enough to cause drops to drip from item being checked/inspected.
 - Class III Leakage of fluid great enough to form drops that fall from the item being checked/inspected.
- Perform weekly as well as before operations PMCS if:
 - (1) You are the assigned operator and have not operated the item since last weekly PMCS.
 - (2) You are operating the item for the first time.

- The Item No. column is used as source of item numbers for the TM Number column on DA Form 2404, Equipment Inspection and Maintenance Worksheet, in recording results of PMCS.

Table 2-1. Operator Preventive Maintenance Checks and Services

NOTE

If the equipment must be kept in continuous operation, check and service only those items that can be checked and serviced without disturbing operation. Make the complete checks and services when the equipment can be shut down.

B - Before D - During A - After
 W - Weekly M - Monthly H - Hourly

Item No.	Interval						Item To Be Inspected procedure	Equipment Is Not Ready/Available If:
	B	D	A	W	H	M		
								
							<p style="text-align: center;">CAUTION</p> <p>Items marked "*" may require daily checking under extreme heat operational conditions.</p>	
*1	•	•					<p>Housing. Check for cracks, breaks, and proper fastening. Check grilles for dirt and debris. Clean as necessary.</p>	Housing or doors missing.
2	•						<p>Choke Control. Check for proper movement.</p>	Choke not working properly.

Table 2-1. Operator Preventive Maintenance Checks and Services (Cont)

B - Before
W - Weekly

D - During
M - Monthly

A - After
H - Hourly

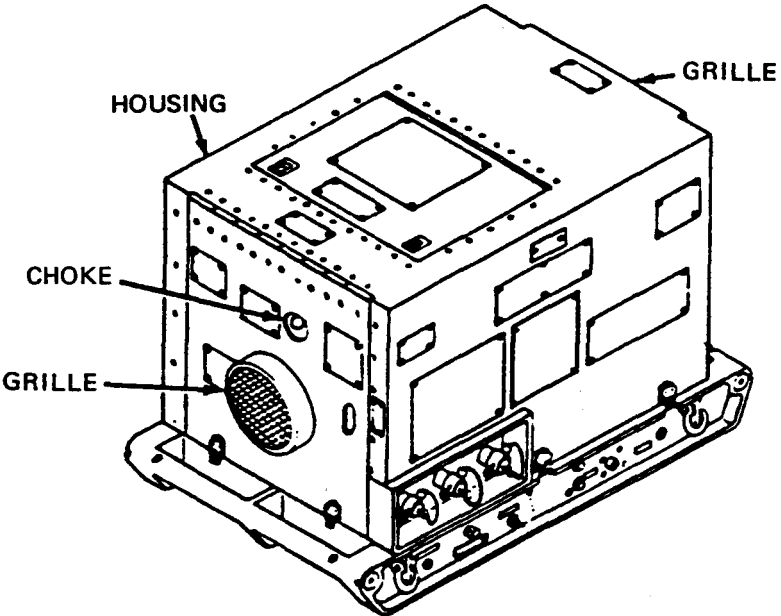
Item No.	Interval						Item To Be Inspected Procedure	Equipment Is Not Ready/Available If:
	B	D	A	W	H	M		
								
3	•	•					<p>Exhaust System. Check muffler for tightness against locknuts. If needed, hand-tighten. Check muffler and manifold for cracks or leaks.</p>	Muffler leaks, cracked or missing.
4	•						<p>Fan. Check for tightness, cracks, and bends.</p>	Fan loose, cracked, or bent.

Table 2-1. Operator Preventive Maintenance Checks and Services (Cont)

B - Before
W - Weekly

D - During
M - Monthly

A - After
H - Hourly

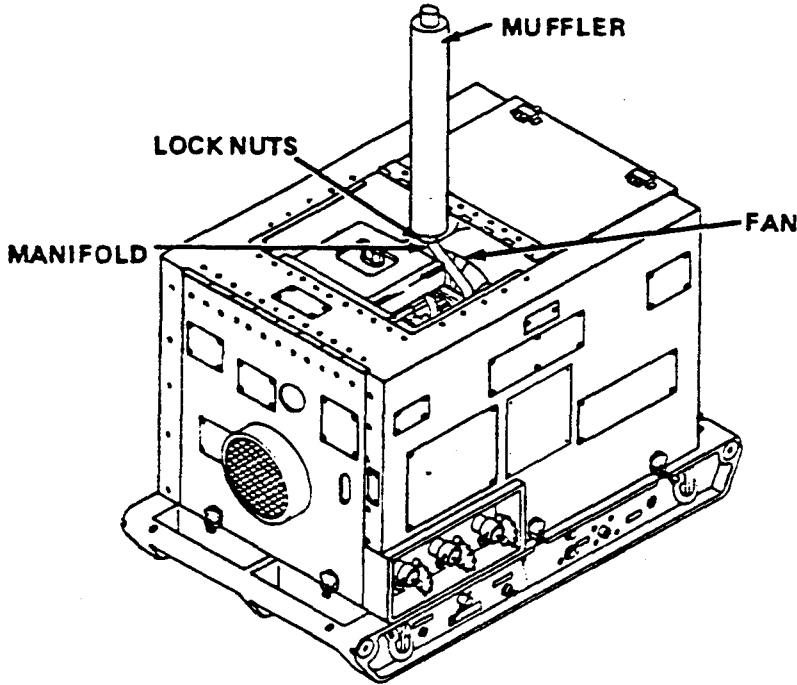
Item No.	Interval						Item To Be Inspected Procedure	Equipment Is Not Ready/Available If:
	B	D	A	W	H	M		
5					•			<p>Belts. Check for wear, cracks, missing teeth, and tightness.</p> <p>Belt worn, cracked, missing teeth, or loose.</p>

Table 2-1. Operator Preventive Maintenance Checks and Services (Cont)

B - Before
W - Weekly

D - During
M - Monthly

A - After
H - Hourly

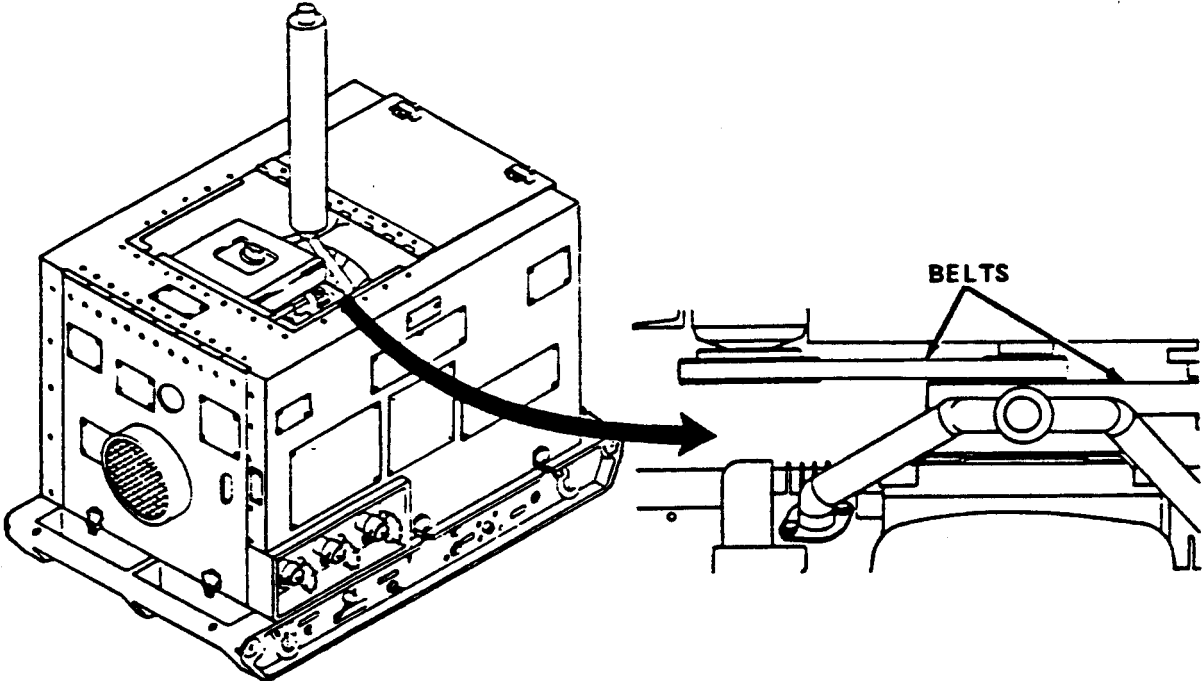
Item No.	Interval						Item To Be Inspected Procedure	Equipment Is Not Ready/Available If:
	B	D	A	W	H	M		
							 <p style="text-align: center;">CAUTION</p> <p>Items marked "*" may require daily checking under saltwater or high humidity operational conditions.</p>	
*6				●			<p>Wiring Harness, Toggle Switch and Pressure Switch Assemblies. Inspect for loose connections, bare wires, and corrosion.</p>	<p>Connections are loose, or wires are bare or corroded.</p>

Table 2-1. Operator Preventive Maintenance Checks and Services (Cont)

B - Before
W - Weekly

D - During
M - Monthly

A - After
H - Hourly

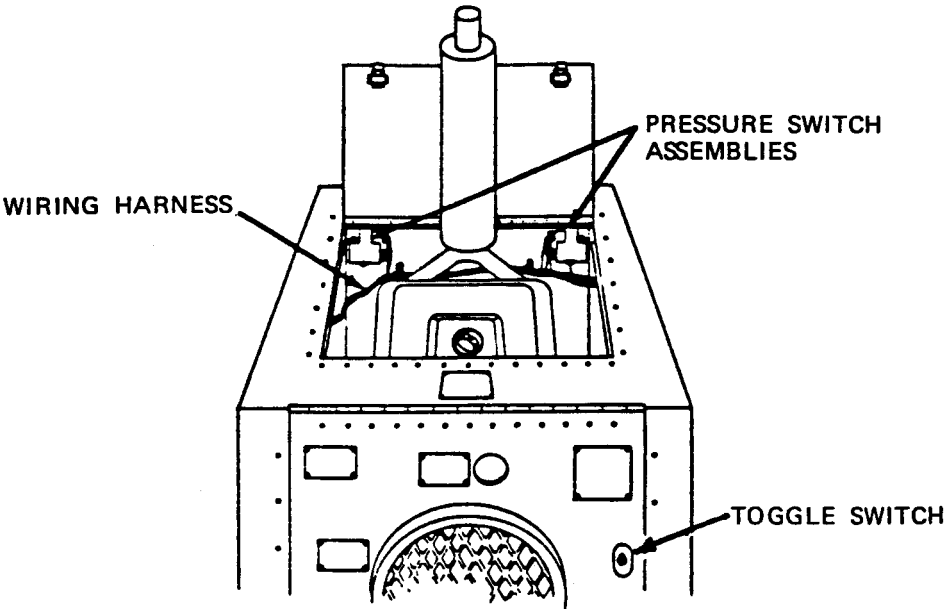
Item No.	Interval						Item To Be Inspected Procedure	Equipment Is Not Ready/Available If:
	B	D	A	W	H	M		
7	•	•					<p>Hoses. Inspect hoses for leakage, chafing, and loose fittings.</p>	<p>Hose leaks, chafing or loose fittings.</p>

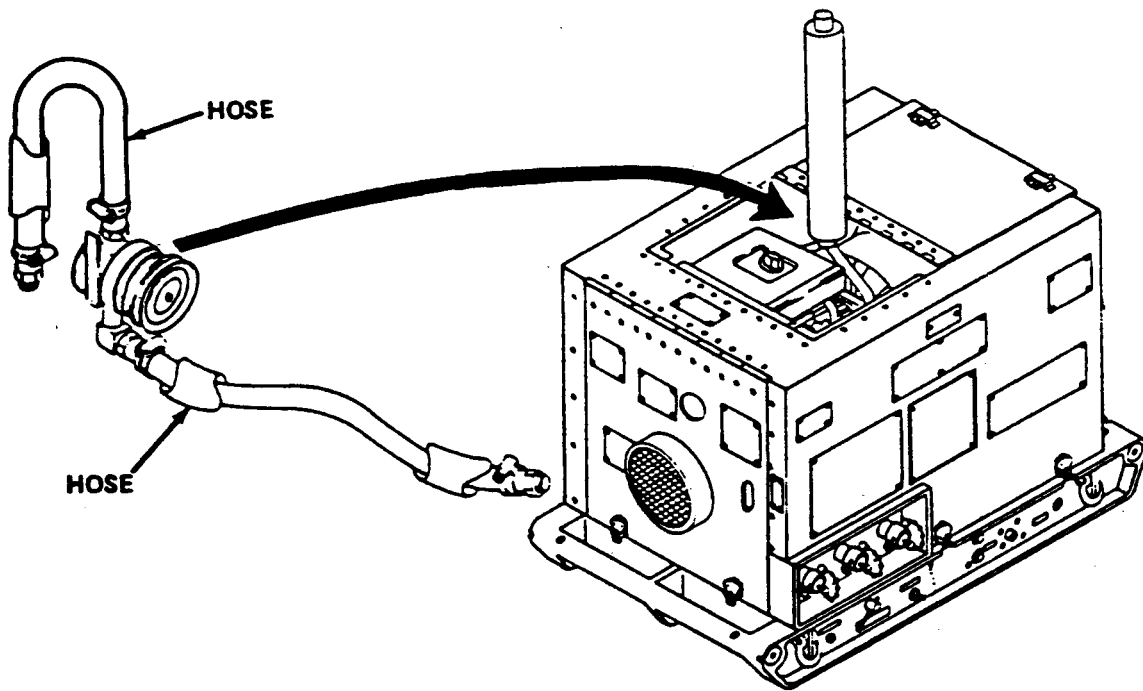

Table 2-1. Operator Preventive Maintenance Checks and Services (Cont)

B - Before
W - Weekly

D - During
M - Monthly

A - After
H - Hourly

Item No.	Interval						Item To Be Inspected Procedure	Equipment Is Not Ready/Available If:
	B	D	A	W	H	M		
* 8	•		•				 <p style="text-align: center;">CAUTION</p> <p>Items marked "*" may require daily checking under extreme heat operational conditions.</p> <p>Crankcase Oil. Check level. Add oil (item 17, appendix E) as necessary to FULL mark of dipstick.</p> <p>Oil level below ADD mark on dipstick.</p>	

Table 2-1. Operator Preventive Maintenance Checks and Services (Cont)

B - Before
W - Weekly

D - During
M - Monthly

A - After
H - Hourly

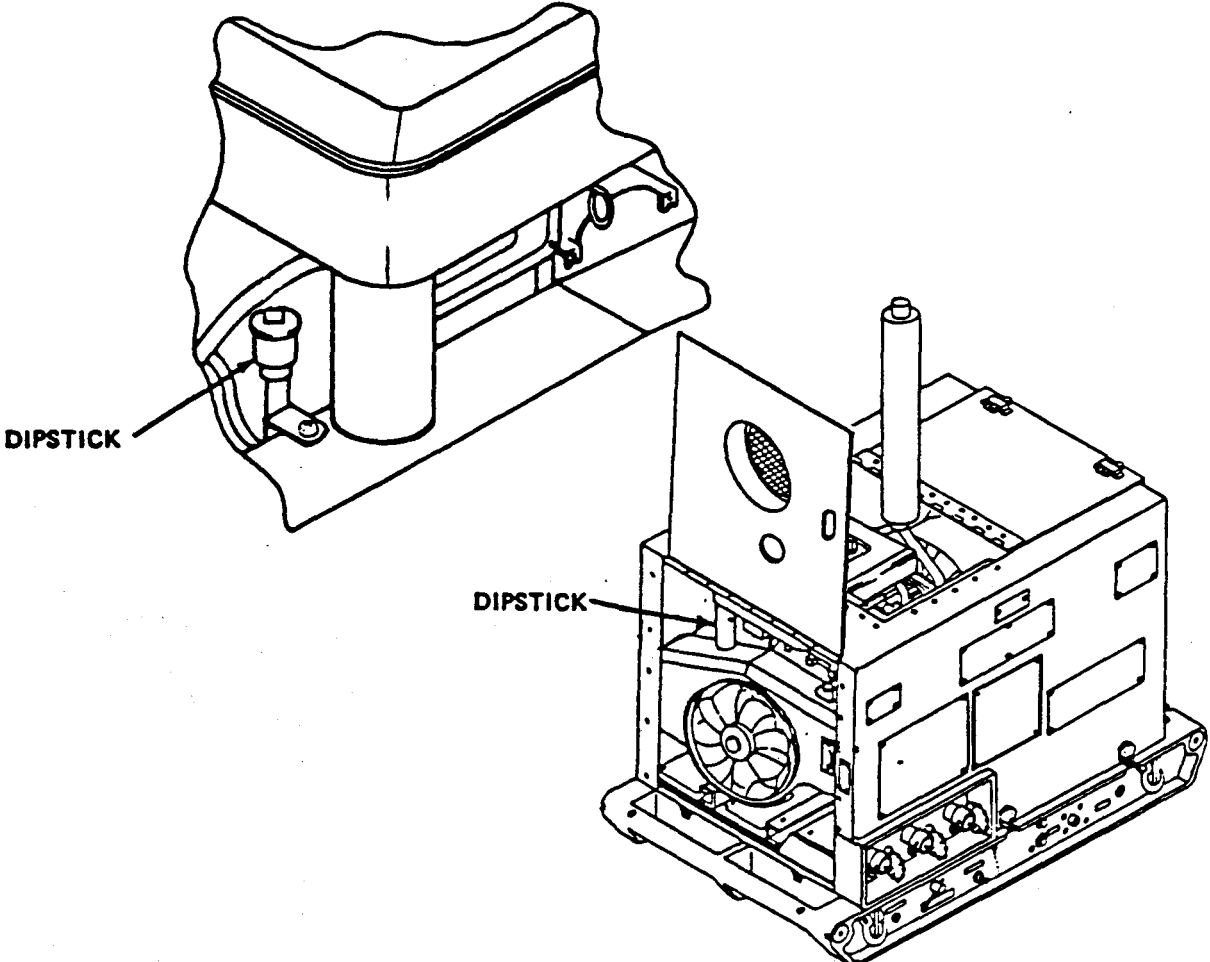
Item No.	Interval						Item To Be Inspected Procedure	Equipment Is Not Ready/Available If:
	B	D	A	W	H	M		

CAUTION

Items marked "*" may require daily servicing under dusty or sandy operational conditions.

*9				●		25	Air Cleaner Foam Precleaned. After 25 hours of engine operation or weekly, whichever comes first, remove and service. (See paragraph 3-5.)	Foam precleaned dirty.
*10						100 ●	Air Cleaner Paper Cartridge. After 100 hours of engine operation or monthly, whichever comes first, remove and clean. (See paragraph 3-6.)	Cartridge dirty.

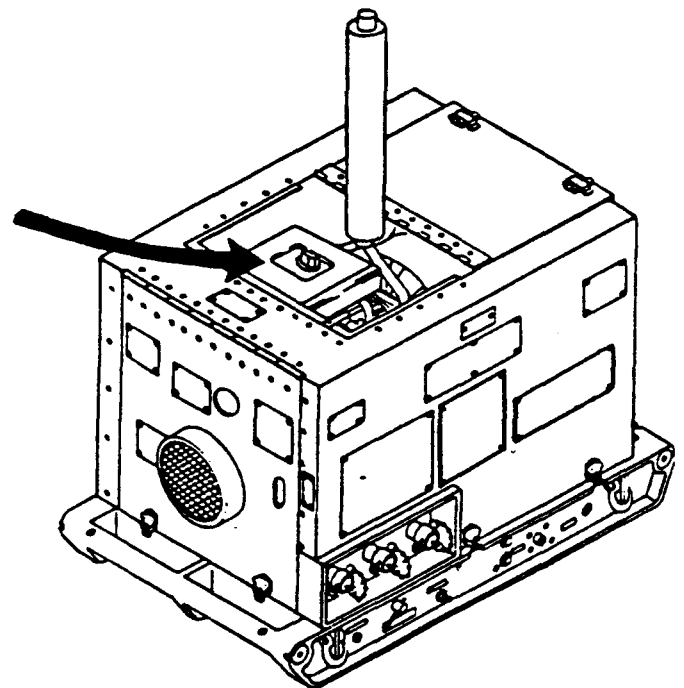
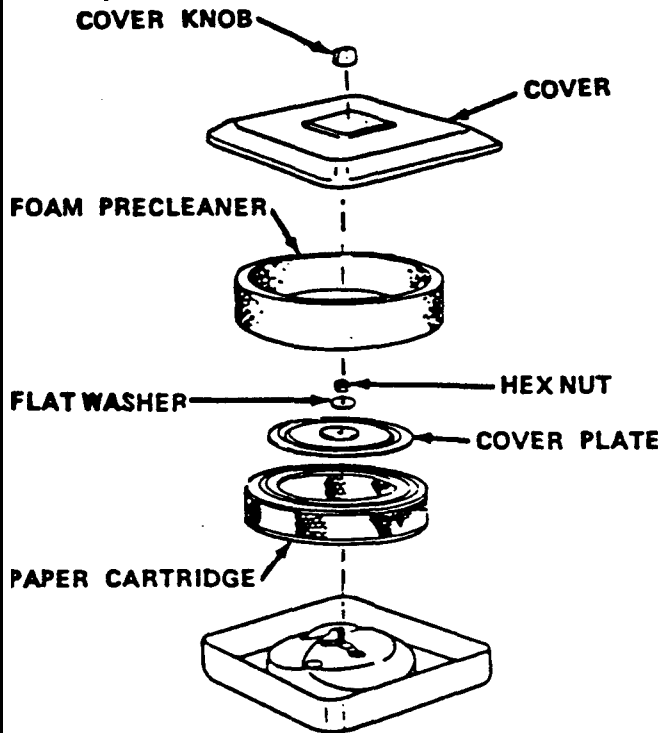

Table 2-1. Operator Preventive Maintenance Checks and Services (Cont)

B - Before
W - Weekly

D - During
M - Monthly

A - After
H - Hourly

Item No.	Interval						Item To Be Inspected Procedure	Equipment Is Not Ready/Available If
	B	D	A	W	H	M		
							 <p>12 VOLT INPUT FOR STARTING CONNECTION</p> <p>START RUN WATER CONTROL</p> <p>REFRIGERANT SIGHT GLASS</p>	
11	●						<p>START RUN Water Control. (Ball Valve Assembly) Turn control back and forth to check operation.</p>	Control will not move.
12			●				<p>12 VOLT INPUT FOR STARTING Connection. Check for damage.</p>	Starting connection damaged.
13		●					<p>Refrigerant. Look through REFRIGERANT SIGHT GLASS after 15 to 20 minutes of operation.</p>	REFRIGERANT SIGHT GLASS not showing clear, bubble-free refrigerant with green center.

Table 2-1. Operator Preventive Maintenance Checks and Services (Cont)

B - Before
W - Weekly

D - During
M - Monthly

A - After
H - Hourly

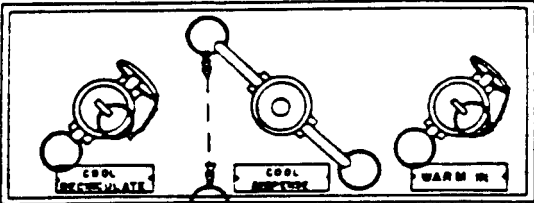
Item No.	Interval						Item To Be Inspected Procedure	Equipment Is Not Ready/Available If:
	B	D	A	W	H	M		
14	•						<p>Skid. Check for cracks and broken welds. Clean as needed. Check quick release pins securing carrying handles. Check carrying handles.</p>	<p>Skid cracked or weld broken. Quick release pins damaged or missing. Carrying handles damaged or missing.</p>
CAUTION								
Items marked "*" may require daily checking under dusty or sandy operational conditions.								
*15				•			<p>Condenser. Check for dirt and debris.</p>	<p>Condenser full of dirt or debris.</p>

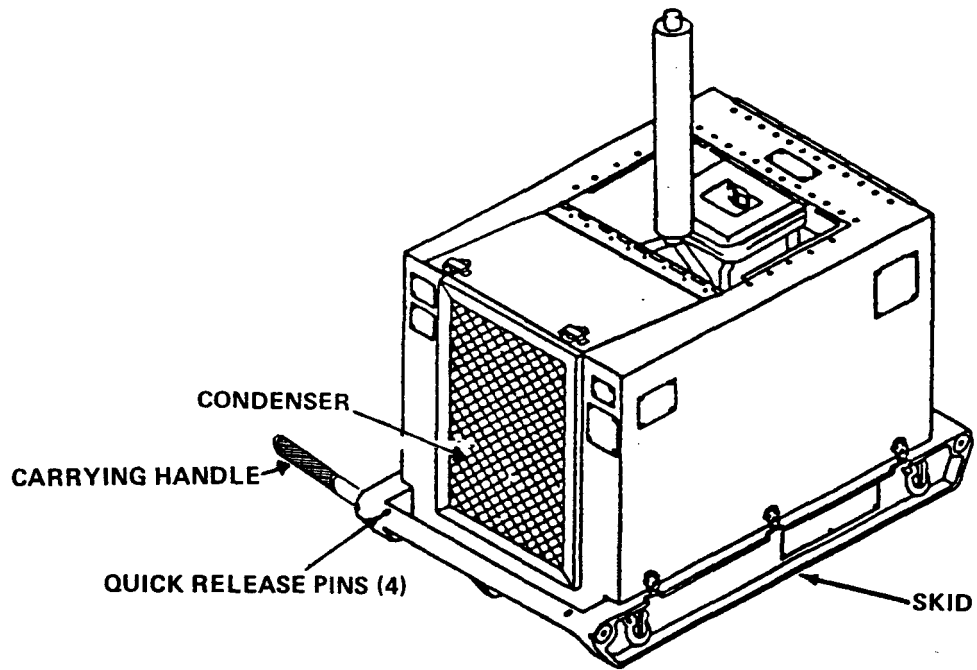

Table 2-1. Operator Preventive Maintenance Checks and Services (Cont)

B - Before
W - Weekly

D - During
M - Monthly

A - After
H - Hourly

Item No.	Interval						Item To Be Inspected Procedure	Equipment Is Not Ready/Available If:
	B	D	A	W	H	M		
							 <p>TRAILER MOUNTING KIT</p>	
16	●						<p>Trailer Mounting Kit. Check that mounting hardware is tight.</p>	Mounting hardware loose.
17	●						<p>Fuel Line. Check for damage and leaks.</p>	Any fuel leak or line damage.

Table 2-1. Operator Preventive Maintenance Checks and Services (Cont)

B - Before
W - Weekly

D - During
M - Monthly

A - After
H - Hourly

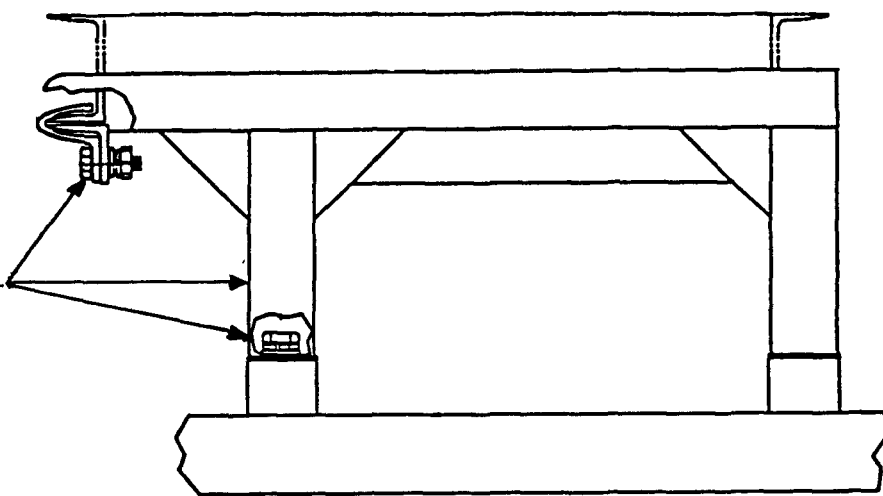
Item No.	Interval						Item To Be Inspected Procedure	Equipment Is Not Ready/Available If:
	B	D	A	W	H	M		
18	•	•	•				<p>Fuel. Check level. Fill as required.</p>	Fuel level low.
19	•	•					<p>Water Hoses. Check all water hoses for leaks and cracks.</p>	Hoses are leaking or cracked.
20	•	•					<p>Water Storage. Check supply. Refill with potable water as necessary.</p>	Water supply low.

Section III. OPERATION UNDER USUAL CONDITIONS

2-6. ASSEMBLY AND PREPARATION FOR USE

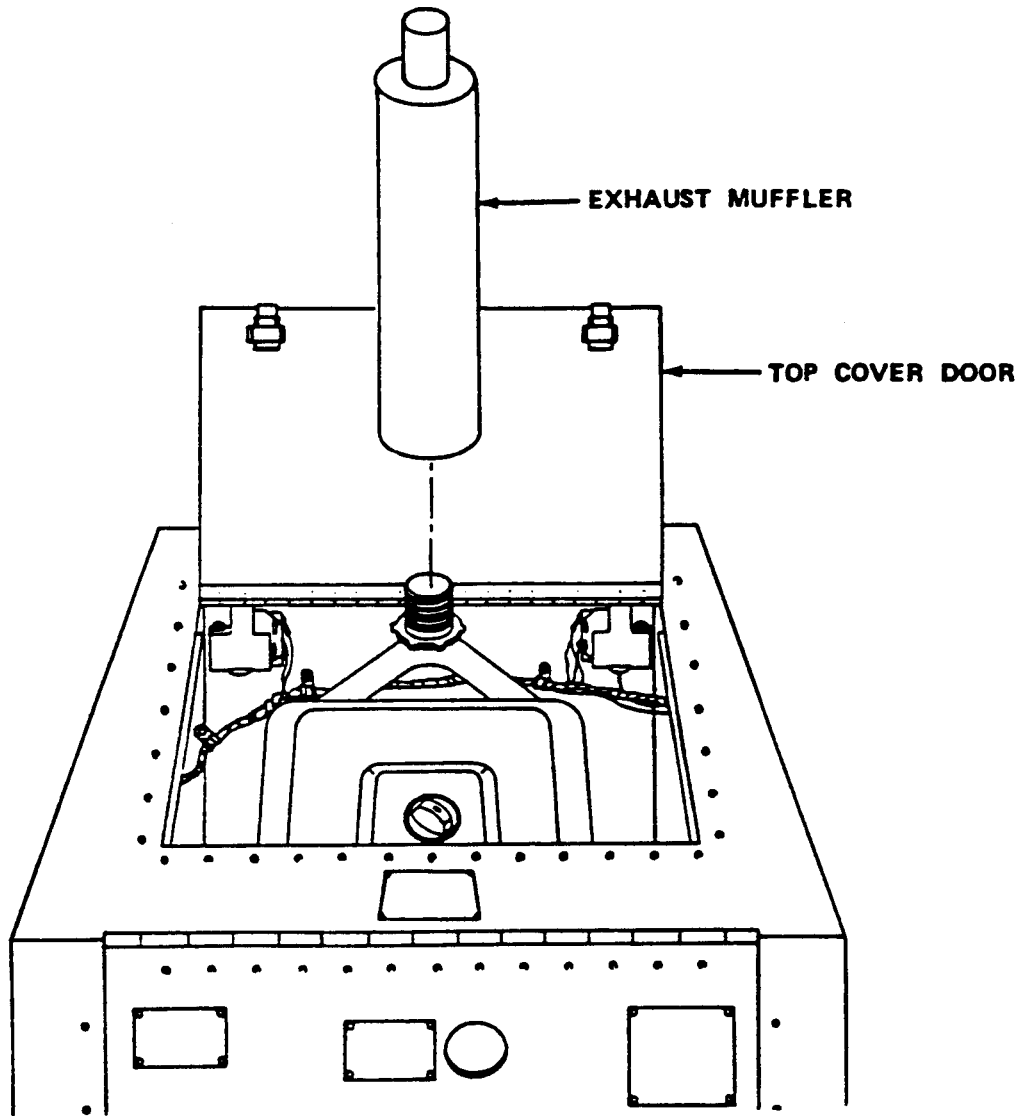

- 1 Unlatch and open top cover door of water chiller.
- 2 Remove muffler from support kit duffle bag. Install exhaust muffler on engine exhaust port. Hand-tighten on existing locknuts.

2-6. ASSEMBLY AND PREPARATION FOR USE (CONT)

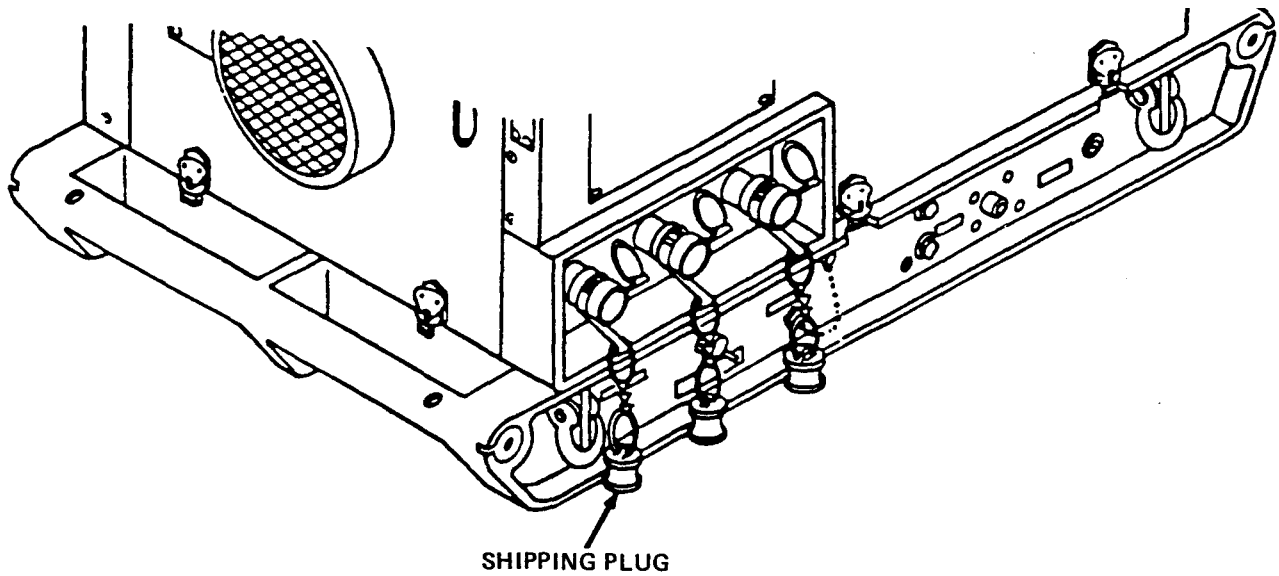

3 Remove shipping plugs from COOL RECIRCULATE, COOL DISPENSE, and WARM IN connections. Make sure no foreign matter is in openings.

4 Remove fuel line nozzle assembly, four water hoses, and strainer assembly from support kit duffle bag.

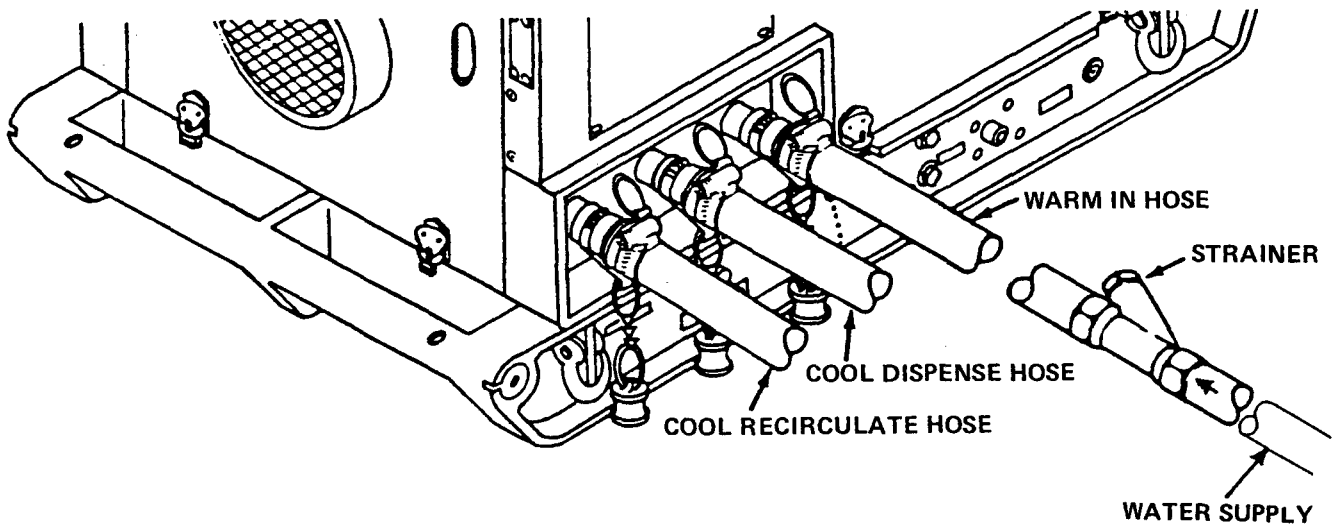

5 Install three hoses in connections on water chiller. Connect free end of hose attached to WARM IN connection to strainer assembly. Connect fourth hose from water supply to other end of strainer assembly. Turn strainer so that arrow on side agrees with flow direction.

2-6. ASSEMBLY AND PREPARATION FOR USE (CONT)

- 6 Route hose from COOL RECIRCULATE connection to return cool water to water supply.
- 7 Attach dispense nozzle assembly to hose connected to COOL DISPENSE connection.

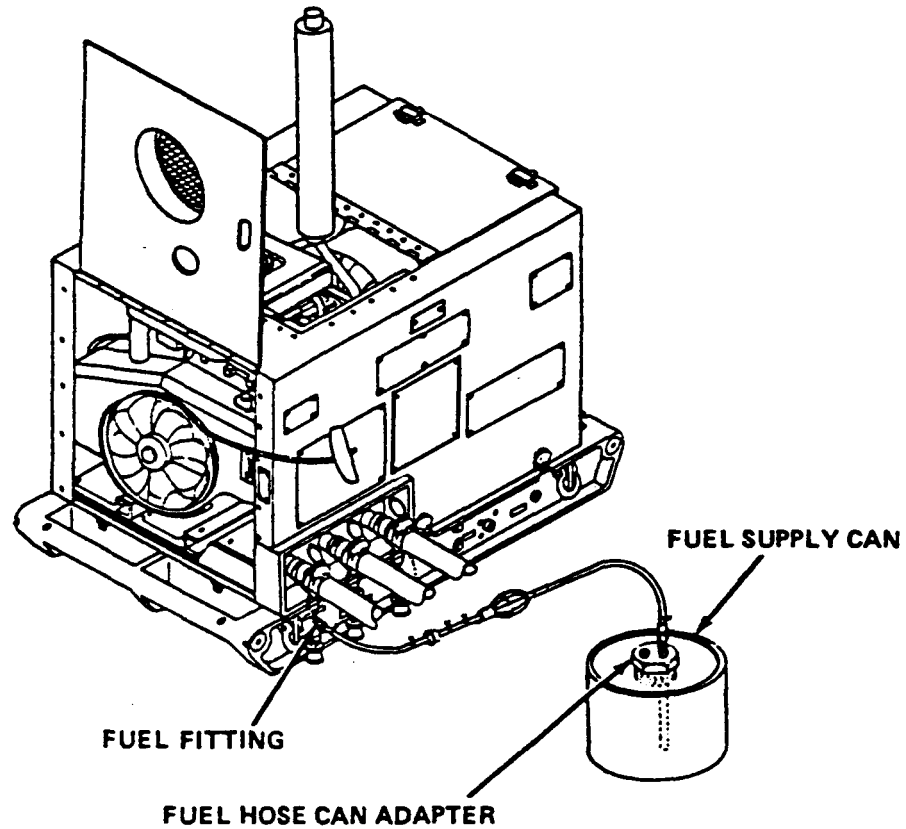

WARNING

Fuel is flammable. To prevent possible fire or explosion, DO NOT bring sparks or open flame near fuel.

- 8 Screw can adapter and fuel hose into fuel supply can. Connect other end of fuel hose to quick-disconnect MOGAS fitting on front of water chiller.

2-7. INITIAL ADJUSTMENTS AND DAILY CHECKS.

- a. Follow "Assembly And Preparations For Use" instructions before proceeding, 2-6.
- b. Inspect all covers, panels, grilles for loose mounting, obstructions, or shipping damage. Report any deficiencies to unit maintenance.
- c. Perform the preventive maintenance checks and services listed in table 2-1.

2-8. OPERATING PROCEDURE.**WARNING**

- Calcium hypochlorite can cause serious injury if not handled properly. Heed all safety measures below. If calcium hypochlorite comes into contact with skin or eyes, flush right away with water. Get medical help.
- Mix only in accordance with directions for use. DO NOT allow calcium hypochlorite to mix with any other materials, such as fuels, oils, paint products, or ammonia. This may cause fire or hazardous gases.

CAUTION

- Store calcium hypochlorite in cool, dry place. Keep container closed.

NOTE

Before using the water chiller after shipment or repairs, the system must be purged with disinfectant.

a. Purging the Water System.

- 1 Fill two 5-gallon (19-liter) pails with water. Add 0.1 ounce (2.8 grams) of calcium hypochlorite powder (item 8, appendix E) to each. Stir each pail with a wooden paddle until powder is dissolved.

2-8. OPERATING PROCEDURE (CONT)

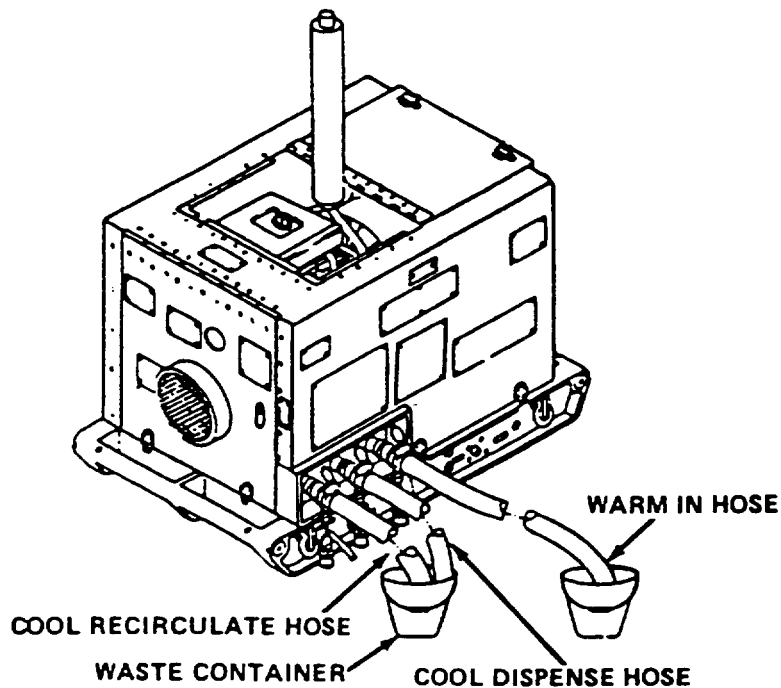

CAUTION

To prevent clogging, do not operate chiller without strainer in WARM IN hose.

- 2 Disconnect hose from water supply at strainer assembly. Place end of WARM IN hose in pail of solution.
- 3 Remove COOL RECIRCULATE hose from top of water supply and place in waste container (5 gallon pail).
- 4 Start water chiller (see paragraph 2-8b, steps 1-6).

2-8. OPERATING PROCEDURE (CONT)

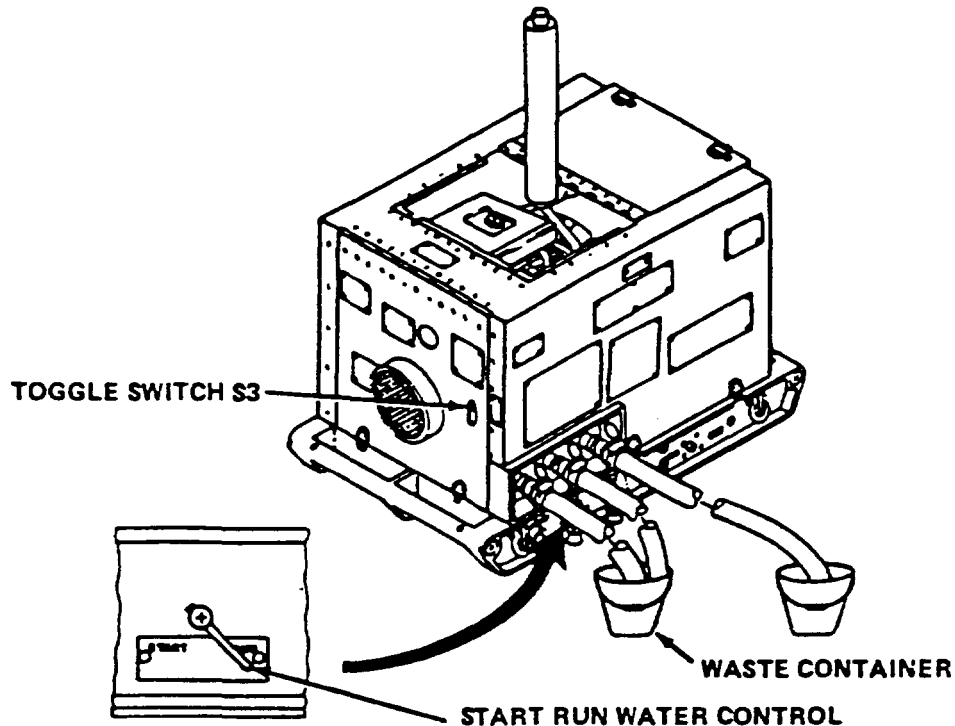
**CAUTION**

To prevent undissolved hypochlorite crystals from entering system, do not use water from bottom of pail. Leave about 1/2 gallon (2 liters) of solution in each pail.

- 5 With engine running, and water flowing out of COOL RECIRCULATE hose place START RUN water control in RUN position.
- 6 Allow chlorine solution to circulate through water system until depleted. Open nozzle on dispensing hose periodically during the cycle and dispense chlorine solution until both pails are empty. Place toggle switch S3 in STOP position. Remove warm in hose from pail.
- 7 Connect WARM IN hose to strainer assembly.

2-8. OPERATING PROCEDURE (CONT)

8 Start engine. (See paragraph 2-8b.) Flush water system thoroughly, discharging water from COOL DISPENSE hose to waste container. Connect COOL RECIRCULATE hose to potable water supply. Water chiller is now ready for operation.

WARNING

- To prevent damage to hearing, wear hearing protection at all times within 4 feet (1.2 meters) of water chiller.
- Do not operate water chiller after shipment or repairs until system has been purged with disinfectant to prevent water contamination. (See paragraph 2-8a.)

CAUTION

- To prevent clogging, DO NOT operate water chiller without strainer. (See para 2-6, step 5.)
- Failure to connect all water hoses may cause damage to equipment. DO NOT operate water chiller without adequate water supply.

NOTE

- Install exhaust muffler and connect water hoses before starting engine. (See paragraph 2-6, step 2).
- Perform before (B) PMCS.

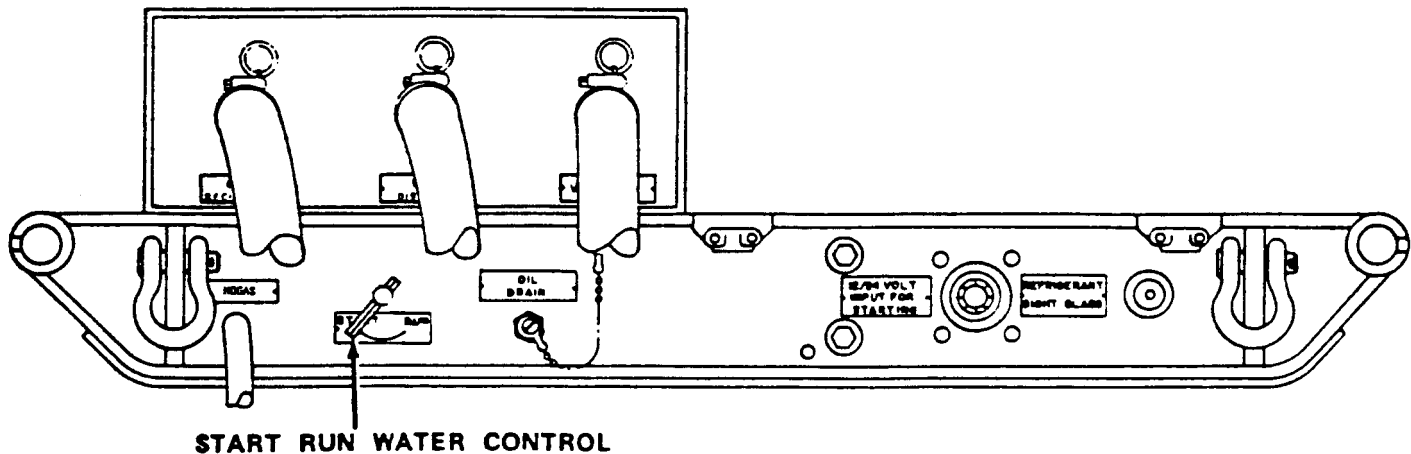

2-8. OPERATING PROCEDURE (CONT)

b. Startup

1 Place START RUN water control in START position.

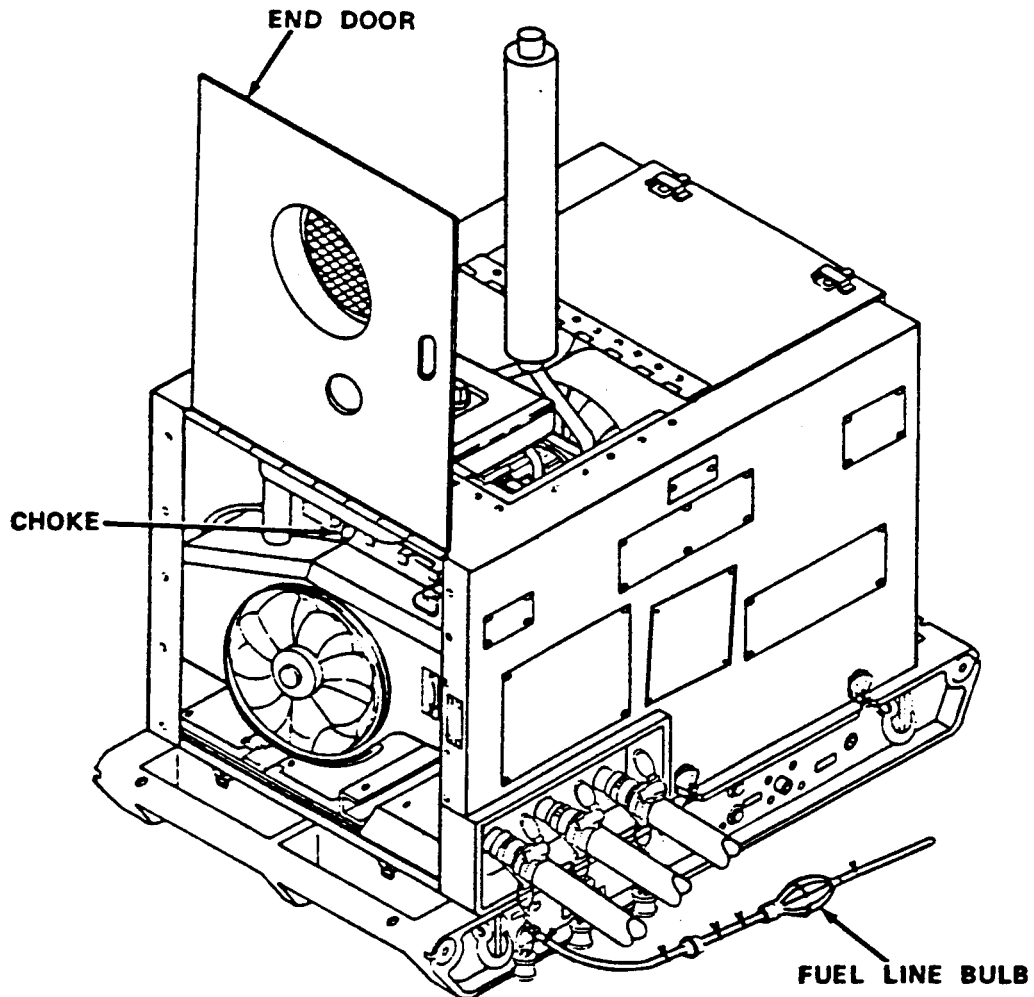

2 Open end door.

NOTE

Choking is usually not required for restarting within 30 minutes after engine temperature reaches 90°F (32°C).

3 If needed, pull out choke to engage.

4 Squeeze and release bulb in fuel line until pressure is felt.

2-8. OPERATING PROCEDURE (CONT)

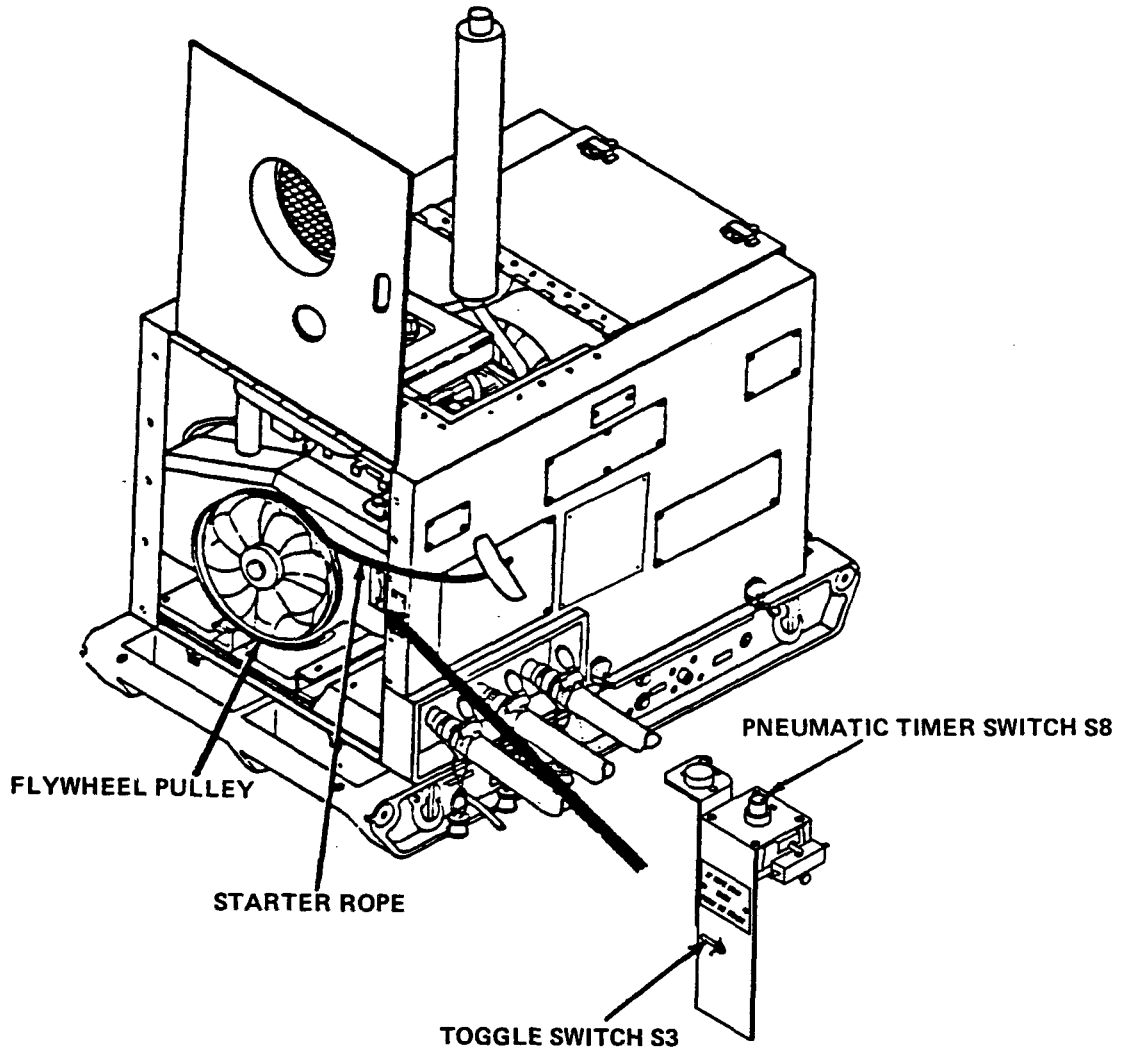

NOTE

Step 5 is for starting when 12 volt power source is not available. Two persons may be required for this step. Step 6 is for starting using 12 volt power source.

- 5 If 12 volt power source unavailable: Wrap starter rope from left to right around flywheel pulley. Push pneumatic timer switch (S8). Pull starter rope. Proceed to step 7.

2-8. OPERATING PROCEDURE (CONT)

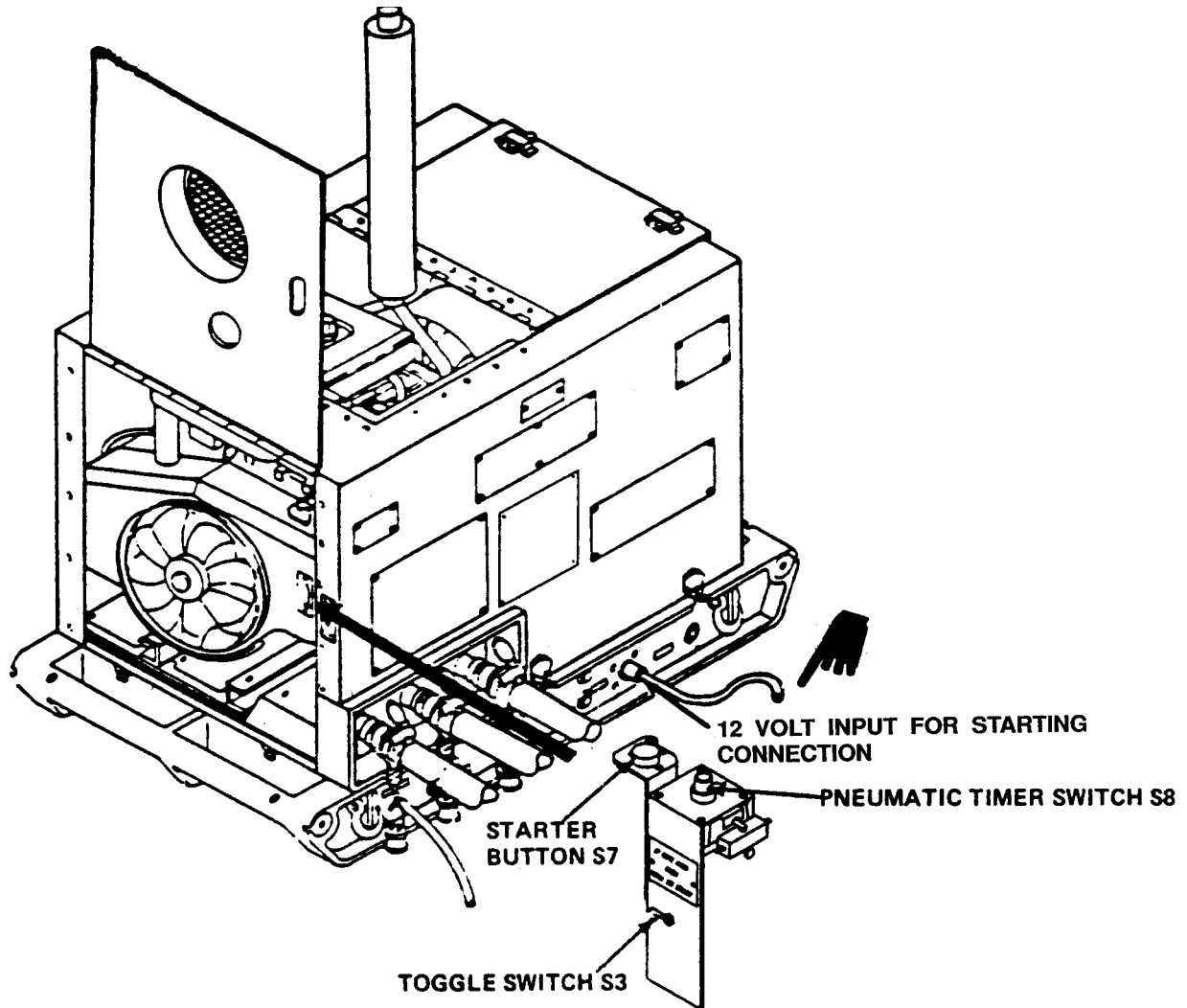
**CAUTION**

To prevent damage to starter:

- If engine fails to start within 15 seconds, release starter button.
- Allow starter to cool at least 10 minutes before trying to restart.
- If only 24 volt power source available, reduce power source to 12 volts.

6. If 12 volt power source available: Insert cable from source into 12 VOLT INPUT FOR STARTING connection. Hold toggle switch S3 in START position. Push starter button S7.

2-8. OPERATING PROCEDURE (CONT)

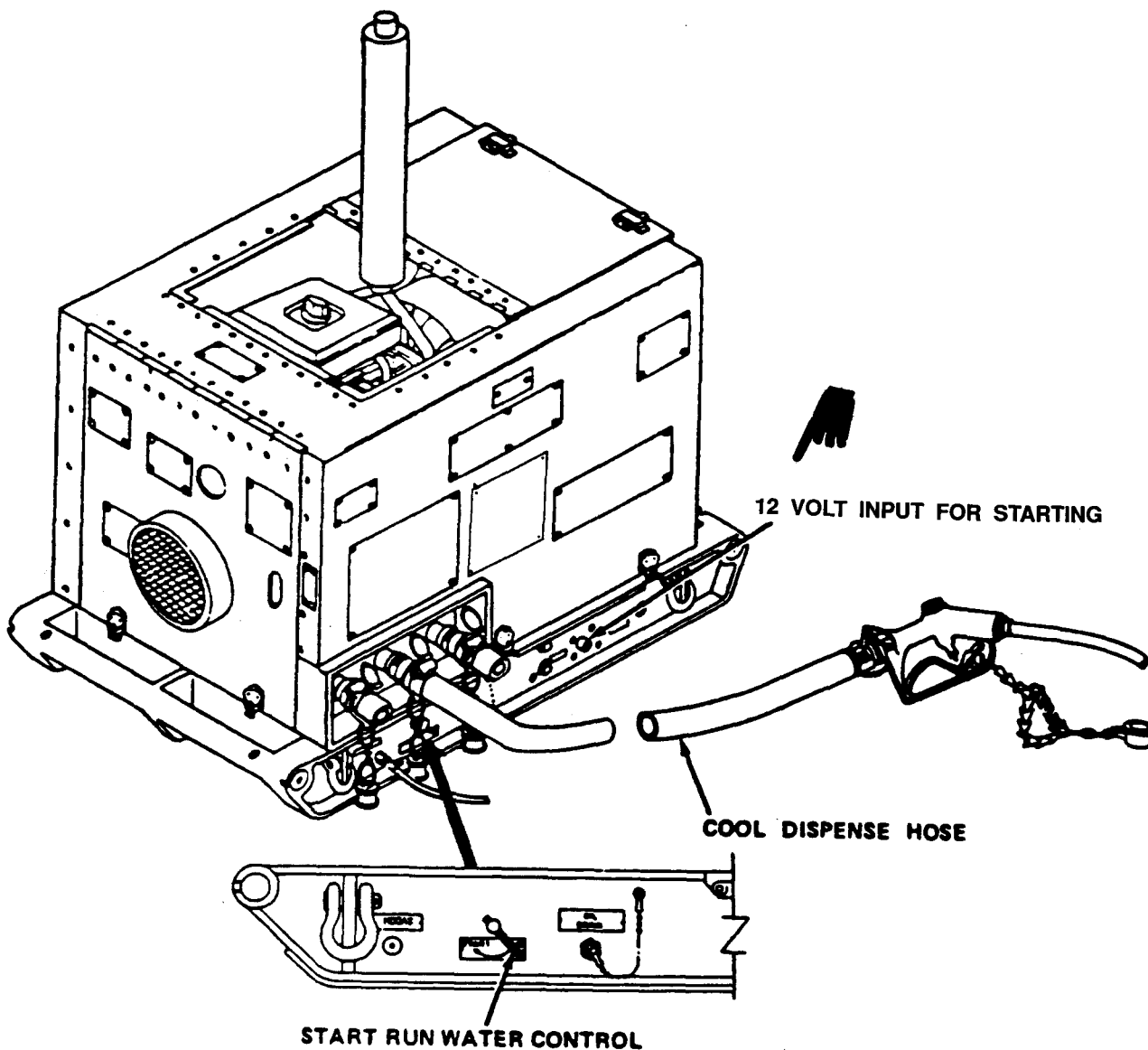

7. Open dispense nozzle. When there are few or no air bubbles in water from cool dispense hose, place START RUN control in RUN position.

■ 8. If used, disconnect power cable from 12 VOLT INPUT FOR STARTING connection.

c. Automatic Shutdown. The water chiller will be automatically shutdown by safety switches under the following conditions:

- Refrigerant pressure too high.
- Refrigerant pressure too low.

2-8. OPERATING PROCEDURE (CONT)

- Water temperature too high.
- Water temperature too low.

d. Shutdown.

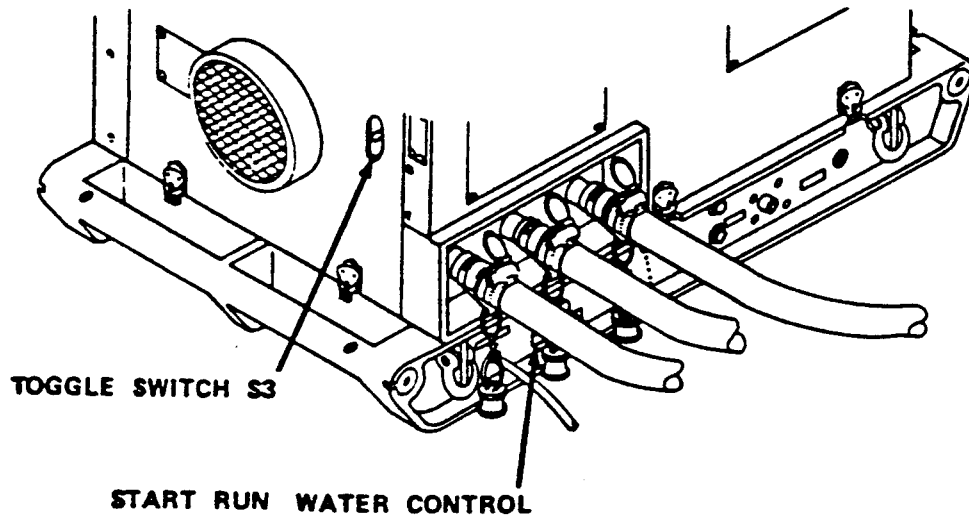

- 1 Hold toggle switch S3 in STOP position until engine stops, then release. Place START RUN water control lever in START position. (Equipment is now in standby condition.)

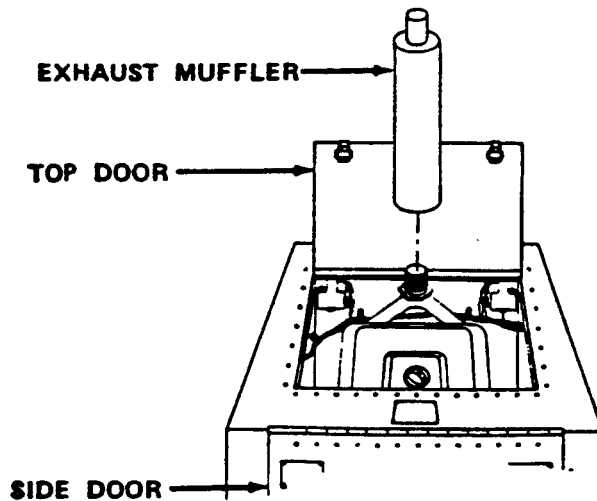

WARNING

To prevent burns, wait until exhaust muffler cools before trying to remove it.

- 2 Remove exhaust muffler. Place in support kit duffle bag.

2-8. OPERATING PROCEDURE (CONT)

3 Close and latch top and side doors.

4 Disconnect fuel line and place in support kit duffle bag.

2-9. PREPARATION FOR MOVEMENT.

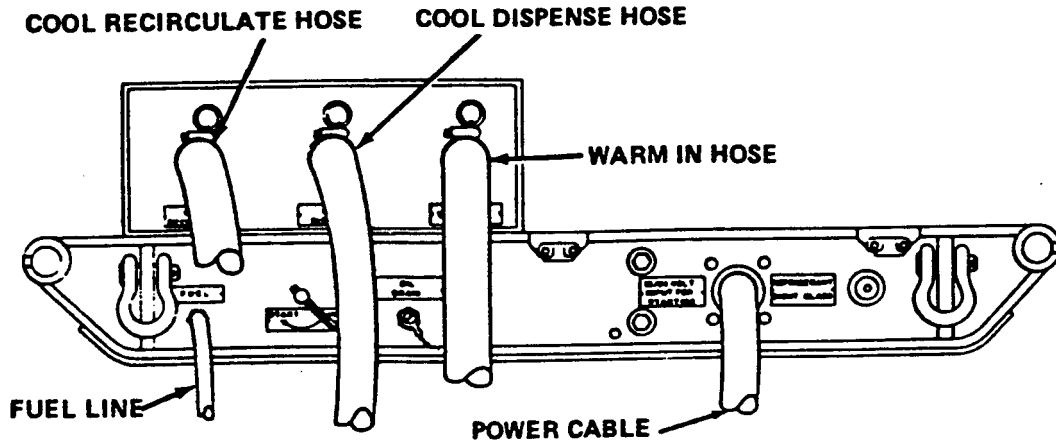

1 Shutdown water chiller. (See paragraph 2-8d.)

WARNING

Fuel is flammable. To prevent possible fire or explosion, DO NOT bring sparks or open flame near fuel.

- 2 Disconnect fuel hose from water chiller and from fuel supply. Drain and place in support kit duffle bag.
- 3 Disconnect three water hoses from water chiller connections. Install shipping plugs. Disconnect hose from water storage tank tee and strainer assembly. Drain hose strainer assembly and nozzle assembly and place in support kit duffle bag.

2-10. OPERATING INSTRUCTIONS ON DECALS AND INSTRUCTION PLATES

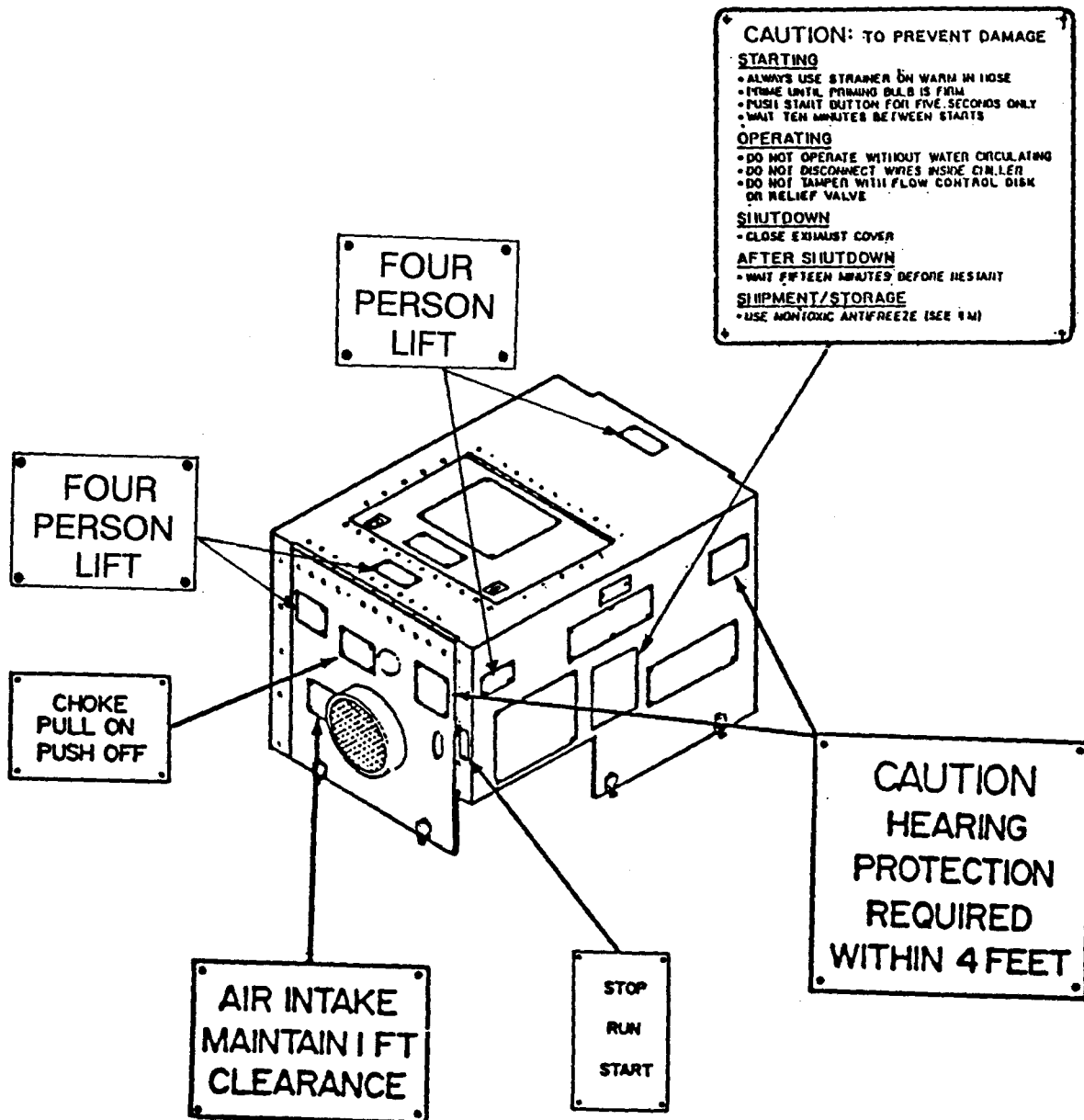

2-10. OPERATING INSTRUCTIONS ON DECALS AND INSTRUCTION PLATES (CONT)

SMWC

OPERATING PROCEDURE: Refer to O & M Manual regarding sanitizing and maintenance,

START-UP PREPARATION

- Remove auxiliary equipment from duffle bag
- Route water hose from supply source and connect to strainer kit assembly
- Turn strainer so that arrow on side agrees with flow direction
- Connect a second hose between strainer and WARM IN fitting on SMWC

CAUTION: DO NOT OPERATE WITHOUT STRAINER

- Route a third water hose to return cooled water to supply source
- Connect to COOL RECIRCULATE fitting on SMWC
- Connect nozzle hose to COOL DISPENSE fitting on SMWC
- Open hinged lid of SMWC Leave open while operating
- Check engine oil level, add oil if required. NSN 9150-00-166-6705 (15W40)
- Attach fuel hose to FUEL fitting on SMWC and other end to fuel source, NSN 9130-00-160-1817 (Combat Automotive Type 1)
- Install muffler on exhaust manifold
- Be sure water valves at tanks, if provided, are open
- Hold engine switch in START position
- Turn START RUN handle of SMWC to START position
- Pull CHOKE for cold start

CAUTION: DO NOT RUN ENGINE UNLESS WATER HOSES ARE CONNECTED

Start engine with pull cord or with 24 or 12 volt DC power source to SLAVE RECEPTACLE. After approximately 10 seconds of operation, turn START RUN handle to RUN position. Release engine switch to return to RUN. Water will automatically recirculate to supply source when COOL DISPENSE nozzle is not in use.

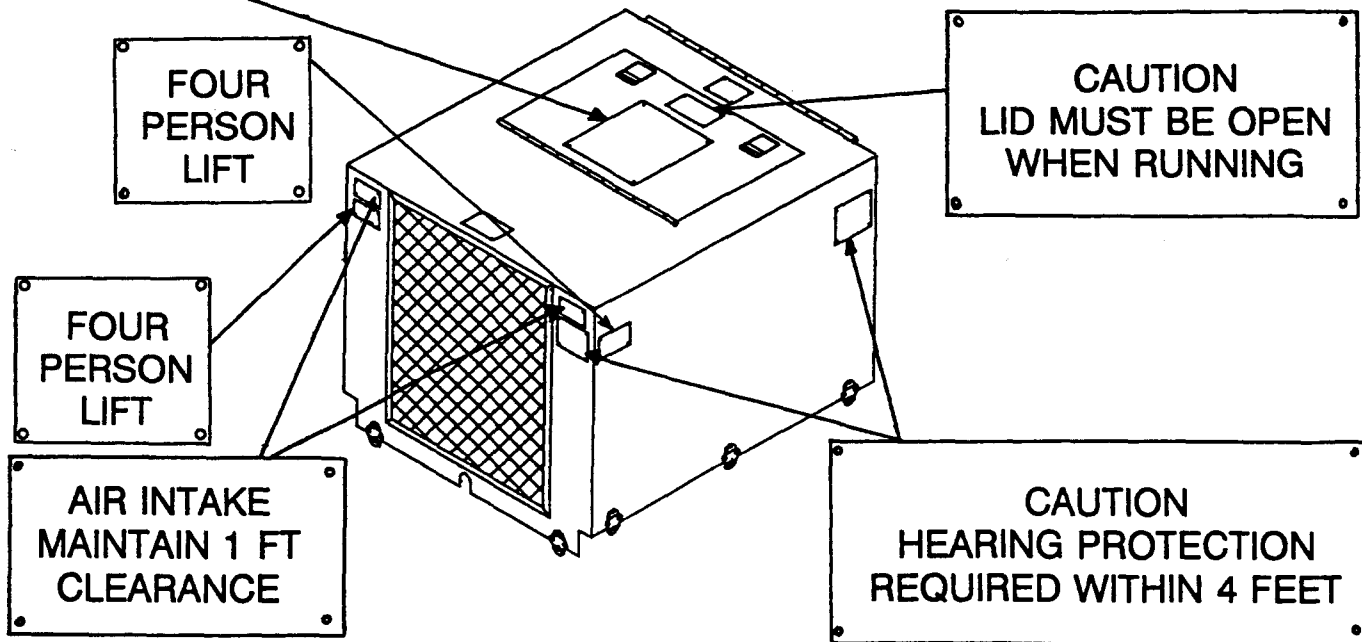

Section IV. OPERATION UNDER UNUSUAL CONDITIONS

2-11. GENERAL. The Small Mobile Water Chiller is designed to operate normally within a wide range of climatic conditions. However, some extreme conditions require special operating and servicing procedures to prevent undue loading and excessive wear on the equipment.

2-12. OPERATION IN EXTREME HEAT. The water chiller is designed to operate in temperatures up to 120°F (49°C). Extra care should be taken to minimize the cooling load when operating in extreme high moist or dry temperatures. Some of the steps that may be taken are:

- a. When possible, use shades or awnings to shut out direct rays of the sun.
- b. Check that the fan belts are tight and not slipping.
- c. Store water containers in shade prior to filling.
- d. Shade the water to be cooled as long as possible prior to cooling in order to get the best results.

2-13. OPERATION IN SALT AIR/SEA SPRAY. Exposed areas should be spray-rinsed or sponged with clear water periodically to remove salt encrustations.

2-14. OPERATION IN SANDY/DUSTY CONDITIONS.

- a. Sand and dust can seriously reduce the efficiency of the water chiller by obstructing the paper cartridge and foam precleaned reducing airflow. Clean cartridge and precleaned daily if necessary.
- b. Check the condenser for blockage reducing the air flow through the coil. Clean condenser daily if necessary to provide unobstructed air flow.
- c. Replace fuel filter weekly.

2-15. OPERATION IN HIGH ALTITUDES. Operating efficiency will be reduced with the increase in altitude. A loss of approximately 20% will be realized at one mile.

2-16. EMERGENCY PROCEDURES .

a. General. The water chiller may be operated in an emergency if non-critical damage occurs to external components or it becomes inoperative due to a shutdown by built-in safety devices.

b. Damage.

(1) Case/Exhaust System. If the water chiller case or muffler becomes damaged, remove the damaged component(s) and operate the unit

2-16. EMERGENCY PROCEDURES (CONT)

as instructed in paragraph 2-8b. Special caution should be taken because moving parts may be exposed.

(2) Fuel Line or Quick-Disconnect. If the fuel line or quick-disconnect become damaged, connect a temporary fuel hose to carburetor fuel inlet barb. Prime the carburetor fuel bowl. Start the water chiller and run in the normal operating mode (paragraph 2-8b.) . (Because the fuel cooler will be bypassed, vapor lock and fuel loss to the engine may occur during high temperature operation.)

CAUTION

Do not allow the water chiller to operate more than ten seconds without water circulating through the system. Check the water outlet to ensure water circulation, to prevent damage to the water pump impeller. It is protected by the temperature sensor only when ignition switch is in run position.

c. Automatic Shutdown. The water chiller is designed to shutdown automatically when the water pump temperature sensor exceeds 130°F (54.5°C). This safety feature is to protect the water pump neoprene impeller from damage by running dry. To reset the temperature sensor, the water pump housing and/or water temperature must be reduced below 130°F (54.5°C). Water can be circulated through the system by bypassing the safety sensors. This can be accomplished by placing the water valve in the RUN position and holding the spring-loaded ignition switch (S3) in the START position. When the water temperature and/or pump housing temperature drops below 130°F (54.5°C), release the spring-loaded ignition switch (S3) allowing it to return to the RUN position.

CAUTION

Inlet water temperature should not be higher than 100°F (38°C) in the water transfer mode.

d. Water Transfer. The water chiller may be used to transfer (pump) water from one source to another at the rate of approximately five gallons per minute. This can be accomplished by connecting the warm inlet hose to the water source and the recirculating (outlet) hose to a storage container and operating the water chiller with the water valve in the START position.

CHAPTER 3

OPERATOR MAINTENANCE INSTRUCTIONS

INDEX

SECTION	TITLE	PAGE
I.	LUBRICATION INSTRUCTIONS	3-1
II.	TROUBLESHOOTING PROCEDURES	3-1
III.	OPERATOR'S MAINTENANCE PROCEDURES	3-3

Section I. LUBRICATION INSTRUCTIONS

3-1. ENGINE . No operator lubrication instruction for small mobile water chiller engine.

3-2. FAN, WATER PUMP AND COMPRESSOR MOTOR LUBRICATION. The fan drive and water pump bearings are permanently lubricated and sealed. The compressor motor is permanently lubricated. The compressor is complete with lubricant. The rotating parts do not need any additional lubrication.

Section II. TROUBLESHOOTING PROCEDURES

3-3. GENERAL . Table 3-1 contains troubleshooting instructions designed to be useful in diagnosing and correcting unsatisfactory operation or failure of the Water Chiller.

a. The table lists the most common malfunctions which you may find during the operation or maintenance of the water chiller or its components. You should perform the test/inspections and corrective actions in the order listed.

b. This manual cannot list all malfunctions which may occur, nor all tests or inspections and corrective actions. If a malfunction is not listed or is not corrected by listed corrective actions, notify your supervisor.

c. Report any trouble or corrective action beyond the scope of operator maintenance to your supervisor.

Table 3-1. Operator's Troubleshooting

MALFUNCTION	TEST OR INSPECTION	CORRECTIVE ACTION
-------------	--------------------	-------------------

1. CHILLER FAILS TO RUN.

Step 1. Check for supply of fuel.

Replenish fuel supply and check fuel cap vent for restrictions.

Step 2. Check water source for low temperature (below 60°F (16°C)).

The water temperature must be above 65°F (18.3°C) for Normal operation and to prevent automatic shutdown by low temperature water control.

Step 3. Check water source for high temperature (above 130°F (54.4°C)).

The water temperature must be below 125°F (51.7°C) for Normal operation and to prevent automatic shutdown by high temperature water control.

Step 4. Check for below normal water flow.

Clean strainer and or restricted fittings.

Remove kinks from hose.

Step 5. Check for seized engine.

Try to turn engine over with starter cord. If engine will not turn notify Unit Maintenance.

Step 6. Check pressure switches.

Press reset buttons.

Step 7. Check air filter/foam pre-cleaner.

Remove air cleaner cover and inspect filter and foam. Clean or replace dirty items.

3-3. GENERAL (CONT)

Table 3-1. Operator's Troubleshooting (Cont)

MALFUNCTION	TEST OR INSPECTION	CORRECTIVE ACTION
2. UNUSUAL NOISE OR VIBRATION.	Check for loose or damaged muffler.	Tighten or replace muffler.
3. INSUFFICIENT OR NO WATER COOLING.	Check sight glass for milky white or bubbly liquid indicating low or inadequate refrigerant charge.	Notify Unit Maintenance.
4. INSUFFICIENT OR NO WATER FLOW.	Step 1. Verify water supply.	Replenish water supply.
	Step 2. Check for blockage of water strainer.	Clean strainer as necessary.
	Step 3. Check for kinks in water hoses.	Remove kinks from water hoses.

Section III. OPERATOR'S MAINTENANCE PROCEDURES

3-4. GENERAL. This section contains operator/crew maintenance instructions authorized by the Maintenance Allocation Chart (MAC), appendix B, and by the source, maintenance, and recoverability (SMR) coded items to support the water chiller.

3-5. AIR CLEANER FOAM PRECLEANER SERVICE.

DESCRIPTION

This task covers: Service

INITIAL SETUP

Materials/Parts:

Engine oil, item 17, Appendix E

Liquid detergent, item 10, Appendix E

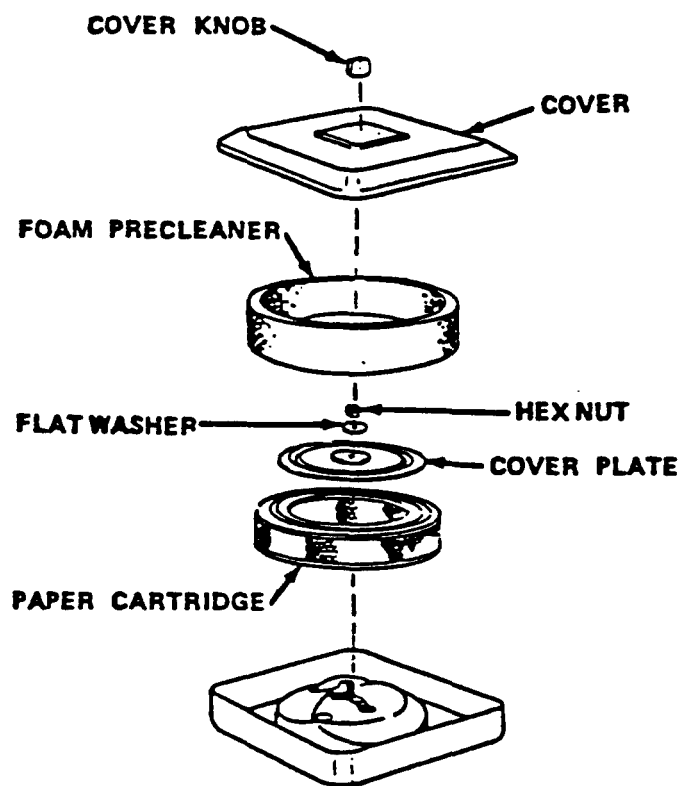

REMOVAL

1. Remove cover knob. Lift off cover.
Remove foam precleaned from around paper cartridge.

CLEANING

1. Wash foam precleaned with liquid detergent and water. Rinse and squeeze dry.
2. Oil with 1 oz (30 cc) of engine oil. Squeeze to spread oil evenly.

3-5. AIR CLEANER FOAM PRECLEANED SERVICE (CONT)

INSTALLATION

1. Install foam precleaned around paper cartridge.
 2. Install cover. Install cover knob.
-

3-6. AIR CLEANER PAPER CARTRIDGE SERVICE.

DESCRIPTION

This task covers: Service

Equipment Condition:

Housing removed.

Materials/Parts:

Rags, Wiping, item 23, Appendix E

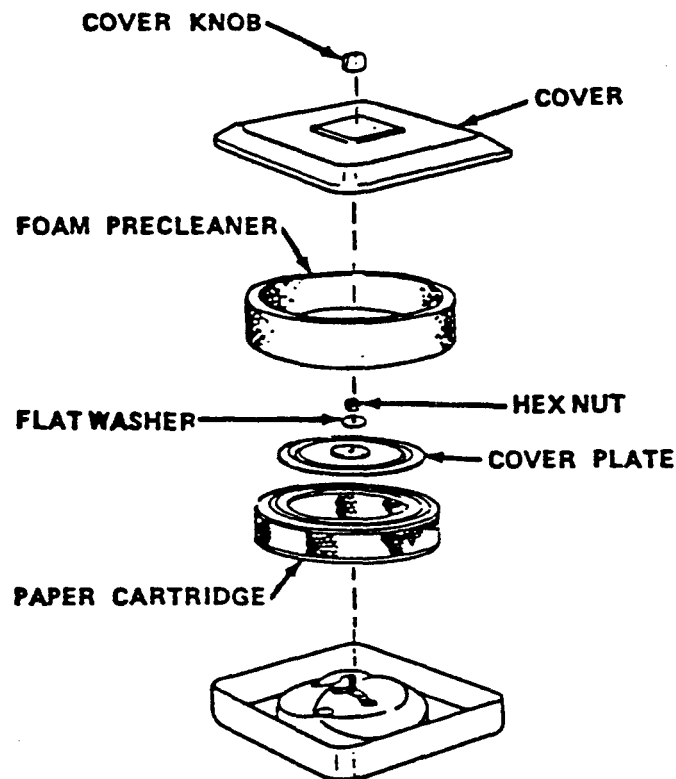

3-6. AIR CLEANER PAPER CARTRIDGE SERVICE (CONT)

REMOVAL

1. Remove cover knob. Lift off cover.
2. Remove foam precleaned from around paper cartridge and clean it (para 3-5).
3. Remove hexnut and flatwasher.
4. Lift off cover plate. Remove paper cartridge.

CLEANING

1. Tap cartridge gently on hard surface and wipe out air cleaner housing with rag.
2. Wipe off cover plate with clean rag.

INSTALLATION

1. Install paper cartridge and cover plate.
2. Install flatwasher and hexnut. Hand-tighten.
3. Install foam precleaned around paper cartridge.
4. Install cover and cover knob.

CHAPTER 4

UNIT MAINTENANCE INSTRUCTIONS

This chapter contains the following frequently used maintenance information.

INDEX		
SECTION	TITLE	PAGE
I.	LUBRICATION INSTRUCTIONS	4-1
II.	REPAIR PARTS; SPECIAL TOOLS; TEST, MEASUREMENT, AND DIAGNOSTIC EQUIPMENT (TMDE); AND SUPPORT EQUIPMENT	4-2
III.	SERVICE UPON RECEIPT	4-2
IV.	UNIT PREVENTIVE MAINTENANCE AND SERVICES (PMCS)	4-8
V.	UNIT TROUBLESHOOTING	4-14
VI.	UNIT MAINTENANCE PROCEDURES	4-19
VII.	PREPARATION FOR STORAGE OR SHIPMENT	4-104

Section I. LUBRICATION INSTRUCTIONS

4-1. ENGINE . The only necessary lubrication for the water chiller is oil for the crankcase. Oil should be changed after 25 hours of operation. During normal engine operation, small particles of metal

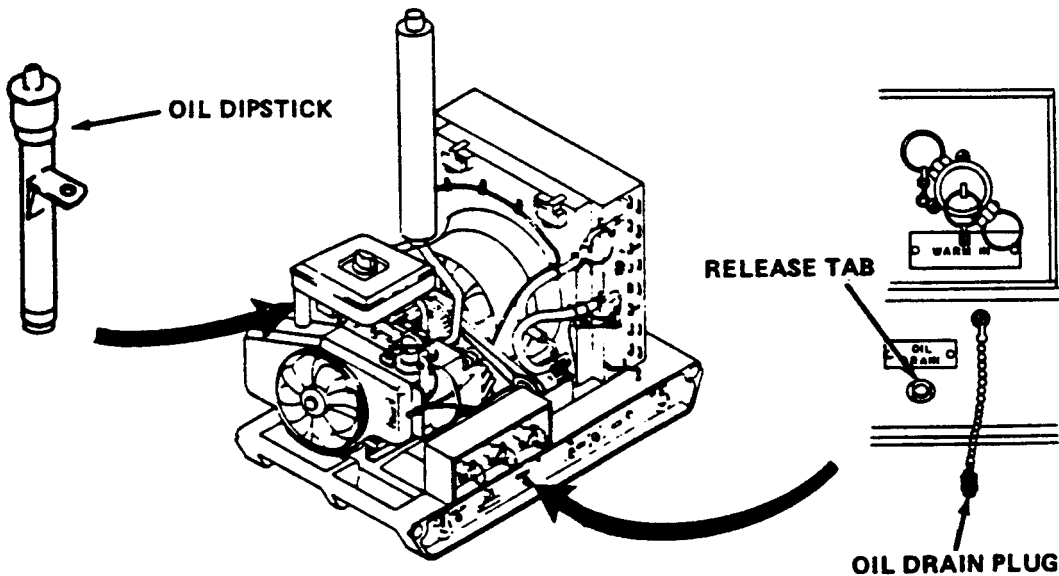

4-1. ENGINE (CONT)

from the cylinder walls, pistons and bearings will gradually contaminate the oil. Dust particles from the air will also contaminate the oil. If the oil is not changed regularly, these foreign particles cause increased friction and a grinding action which shortens the life of the engine. Fresh oil also assists in cooling, old oil gradually becomes thick and loses its cooling ability as well as its lubrication qualities.

1. Place oil drain pan (Appendix D) under OIL DRAIN.
2. Press release tab, pull oil drain plug. Depress plunger and let oil drain. Install plug. Discard waste oil.
3. Pull out dipstick. Fill engine with 3.0 pints (1.42 liters) of oil (item 17, Appendix E) through oil filler tube. Top up to FULL mark on dipstick. Install dipstick.

Section II. REPAIR PARTS; SPECIAL TOOLS; TEST, MEASUREMENT, AND DIAGNOSTIC EQUIPMENT (TMDE); AND SUPPORT EQUIPMENT

4-2. MAINTENANCE REPAIR PARTS. Repair parts are listed and illustrated in TM 10-4130-239-24P, Repair Parts and Special Tools List (RPSTL) , covering Unit, Direct Support, and General Support Maintenance for this equipment.

4-3. COMMON TOOLS AND EQUIPMENT. For authorized common tools and equipment refer to the Modified Table of Organization and Equipment (MTOE) applicable to your unit.

4-4. SPECIAL TOOLS AND TEST EQUIPMENT. Test, Maintenance, Diagnostic Equipment (TMDE) and support equipment include standard equipment found in any unit maintenance shop. A list of illustrated manufactured items are found in Appendix F.

4-5. CONSUMABLE MATERIALS. Refer to Appendix E, Section II for a list of expendable supplies and materials.

Section III. SERVICE UPON RECEIPT

4-6. SERVICE UPON RECEIPT.

a. General. The basic water chiller, support kit and trailer mounting kit are crated and shipped as one item. The support kit and the trailer mounting kit are boxed together and placed inside the crate on top of the water chiller, or on the base of the shipping crate.

b. Unloading. The crated unit should be placed as close as possible to point of use before uncrating.

c. Unpacking.

- 1 Place crated unit as close as possible to point of use.
- 2 Remove steel bands from top of crate, being careful not to damage water chiller components.
- 3 Remove cardboard box containing kits from top of water chiller.
- 4 Open cardboard box and remove contents.
- 5 Inspect all contents for damage.

NOTE

- The cardboard box contains a duffel bag for storing components of support kit after removal from packing box. Select components required for installation from support kit. Store spare support kit components in duffel bag for later use.
 - Check contents using Appendix C, Components of End Item and Basic Issue Items Lists.
- 6 Check support kit contents. These items are required for setting up water chiller as operational unit.
 - 7 Check contents of trailer mounting kit. Do not remove from shipping case until ready for installation.
 - 8 Remove crating from around water chiller and remove hold-down bolts from skid base.
 - 9 Remove water chiller from crating and place at point of operation.

d. Checking Unpacked Equipment.

- 1 Inspect the equipment for damage incurred during shipment. If the equipment has been damaged, report the damage on DD SF 364, Report of discrepancy.
- 2 Check the equipment against the packing slip to see if the shipment is complete. Report all discrepancies in accordance with the instructions of DA PAM 738-750. The Army Maintenance Management System (TAMMS).
- 3 Check to see if equipment has been modified.

4-7. INSTALLATION INSTRUCTION. The basic water chiller is a skid mounted unit which can be used with various types of stationary or mobile potable water storage containers. To provide a self-contained potable water storage and mobile water chiller unit, a trailer mounting kit is provided for modifying the M149A 400 gallon trailer for water chiller installation, as shown in figure 4-1.

4-8. TOOLS, TEST EQUIPMENT, AND MATERIALS REQUIRED FOR INSTALLATION. No special tools required.

4-9 . TRAILER MOUNTING PROCEDURES.

a. Chassis Modifications. If trailer has not been modified with mounting blocks (view B, figure 4-2) refer to Direct Support Maintenance for trailer mounting kit installation.

b. Tank Modifications.

NOTE

ALL parts needed for tank modifications are located in Support Kit Duffle Bag.

- 1 Remove pipe plug from vent hole in tank fill cover.
- 2 Screw quick disconnect elbow connection into existing vent hole (view C, figure 4-1) for water recirculating (return) hose.
- 3 Loosen clamp on hose coupling (view B, figure 4-1) and remove hose coupling from manifold pipe.
- 4 Remove pipe nipple from tank shutoff valve and replace with T-connection with quick disconnect.
- 5 Replace hose coupling (view B, figure 4-1) and secure with hose clamps.

c. Mounting Water Chiller on Trailer.

- 1 If trailer has been modified with mounting blocks, bolt cradle to trailer (view B, figure 4-2).
- 2 Slide water chiller in the cradle. until it stops against the back and locks under tabs (view A, figure 4-2).
- 3 Bolt grab hooks to cradle locking down the front of the water chiller (view B, figure 4-2).
- 4 Figure 4-3 shows water chiller mounted.

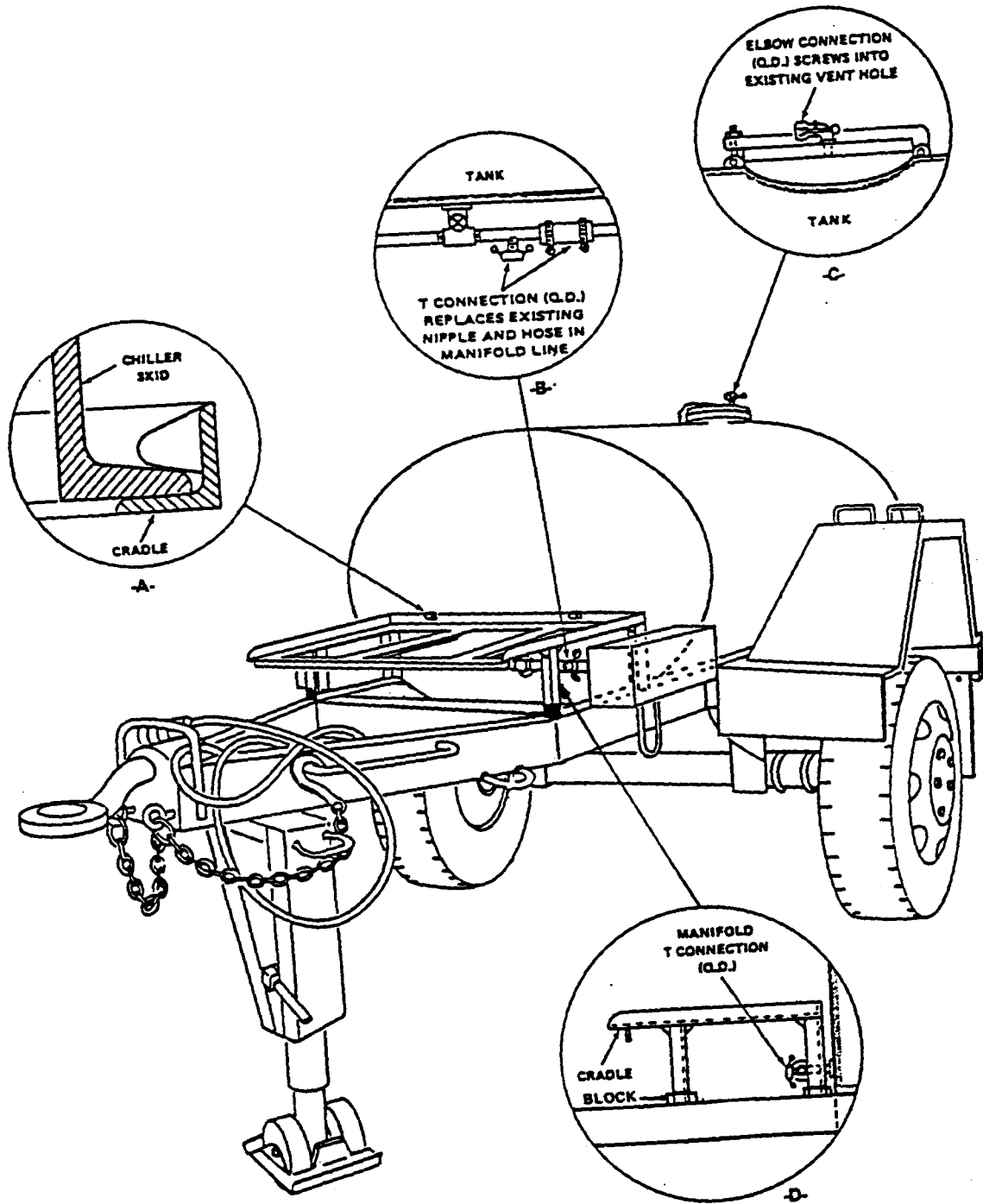

Figure 4-1. Modification of M149A 400 Gallon Trailer Tank for Small Mobile Water Chiller Installation

4-10. **ASSEMBLY OF EQUIPMENT.** Follow "Assembly and Preparations for Use" instructions, paragraph 2-5 and "Initial Adjustments and Daily Checks" instructions, paragraph 2-6.

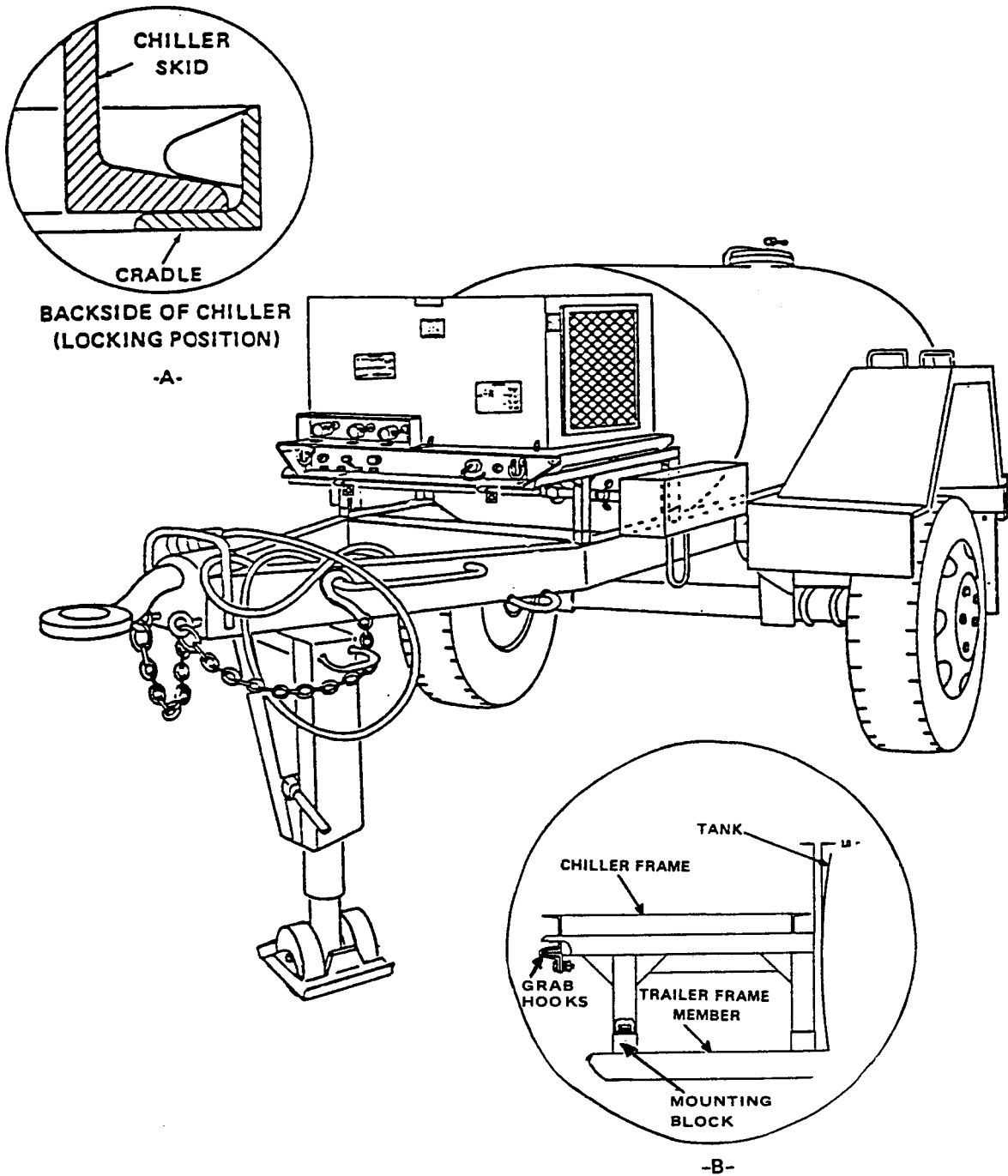

Figure 4-2. Installation of Small Mobile Water Chiller Kit

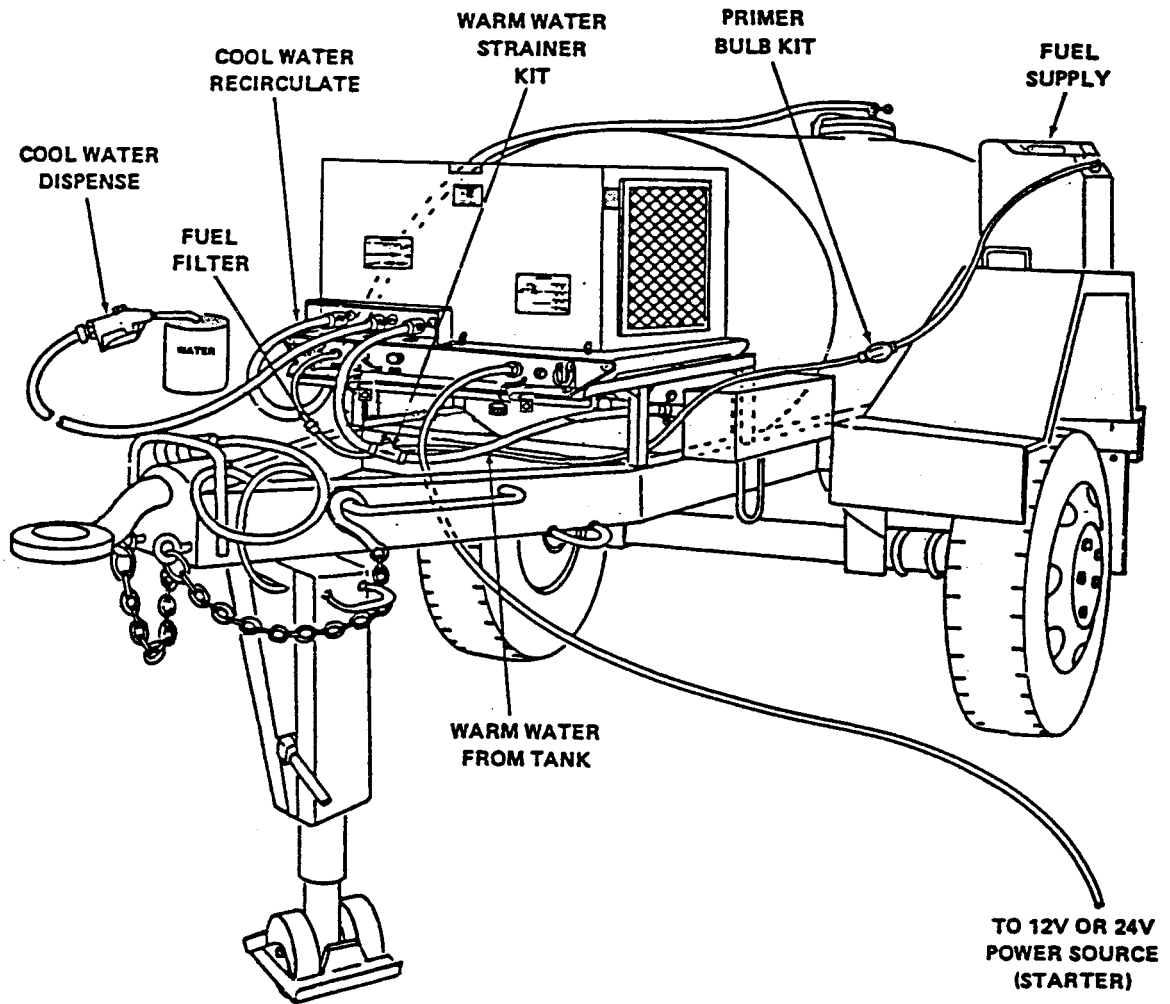

Figure 4-3. Modified M149A 400 Gallon Trailer Tank for Small Mobile Water Chiller Field Use

Section IV. UNIT PREVENTIVE MAINTENANCE AND SERVICES (PMCS)

4-11. GENERAL .

a. Always keep in mind the WARNINGS and CAUTIONS while performing PMCS.

b. Preventative Maintenance Checks and Services (PMCS, Table 4-1) are to be completed to ensure the water chiller is ready to use at all times. These checks and services help you find and repair defects before the water chiller is damaged or fails.

c. All deficiencies and shortcomings shall be recorded together with the corrective action taken on DA Form 2404 (Equipment Inspection and Maintenance Worksheet) at the earliest opportunity.

d. If your equipment fails to operate, troubleshoot with proper equipment. Report any deficiencies using proper forms. (See DA PAM 738-750).

4-12. PMCS PROCEDURE.

a. Purpose. The PMCS table lists the inspections and care of the equipment required to keep it in good operating condition.

b. Use. To perform PMCS, follow the directions listed for each column below.

(1) Item No. This column numbers the checks and services in order of performance. It is the source of item numbers for the TM Number Column on DA Form 2404, Equipment Inspection and Maintenance Worksheet.

(2) Interval. This column tells you when to do a certain check or service. The codes in this column are as follows:

W - Perform these checks and services once per week.

M - Perform these checks and services once per month and upon receipt of new equipment.

H - Perform these checks and services after the number of hours of equipment operation listed in the column.

(3) Item to be Inspected Procedure. This column tells you what item is to be inspected. It also tells you how to do the required checks and services. Carefully follow these instructions. If directed by the procedure, or if you do not have the required tools, refer the equipment to Direct Support maintenance.

4-12. PMCS PROCEDURES (CONT)

c. Housing Removal/Reinstallation. Before performing PMCS, remove muffler and housing. After PMCS, reinstall housing and muffler. (See Paragraphs 4-10 and 4-18.)

Table 4-1. Unit Preventive Maintenance Checks and Services

W - Weekly

M - Monthly

H - Hourly

Item No.	Interval			Item to be Inspected Procedure
	W	M	H	
				
1		•		<p>Carburetor. Remove air cleaner element and air cleaner housing (para 4-26). Check for fuel leakage at fuel and vacuum lines. If leakage is present, replace hose clamp or line. Check for loose mounting bolts and tighten if necessary. Check for cracks. If carburetor is cracked, replace it (para 4-27). Check fuel pump for cracks and for leakage at mounting screws. Tighten mounting screws if necessary. If pump is cracked or leakage still present, replace carburetor (para 4-27) .</p>
2		•		<p>Intake Manifold. Check for cracks or vacuum leaks. Replace cracked manifold or gaskets. Check for loose or missing mounting bolts. Tighten or replace as necessary.</p>

Table 4-1. Unit Preventive Maintenance Checks and Services (Cont)

W - Weekly

M - Monthly

H - Hourly

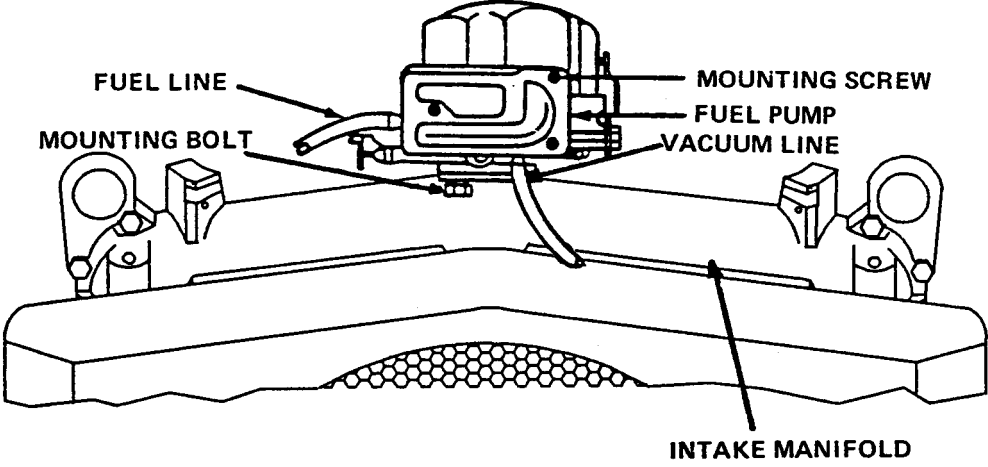
Item No.	Interval			Item to be Inspected procedure
	W	M	H	
3		•		 <p>Starter. Check for loose cable connections. Tighten loose cable connections (para 4-33).</p>
4		•		 <p>Governor Control Assembly. Check for loose mounting bolts. Check governor lever and springs for damage. Tighten loose mounting bolts. Replace governor lever and springs if damaged (para 4-28).</p>

Table 4-1. Unit Preventive Maintenance Checks and Services (Cont)

W - Weekly

M - Monthly

H - Hourly

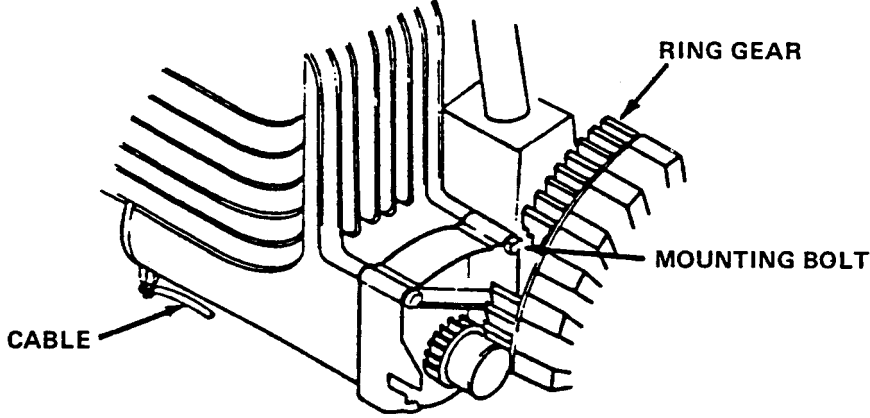
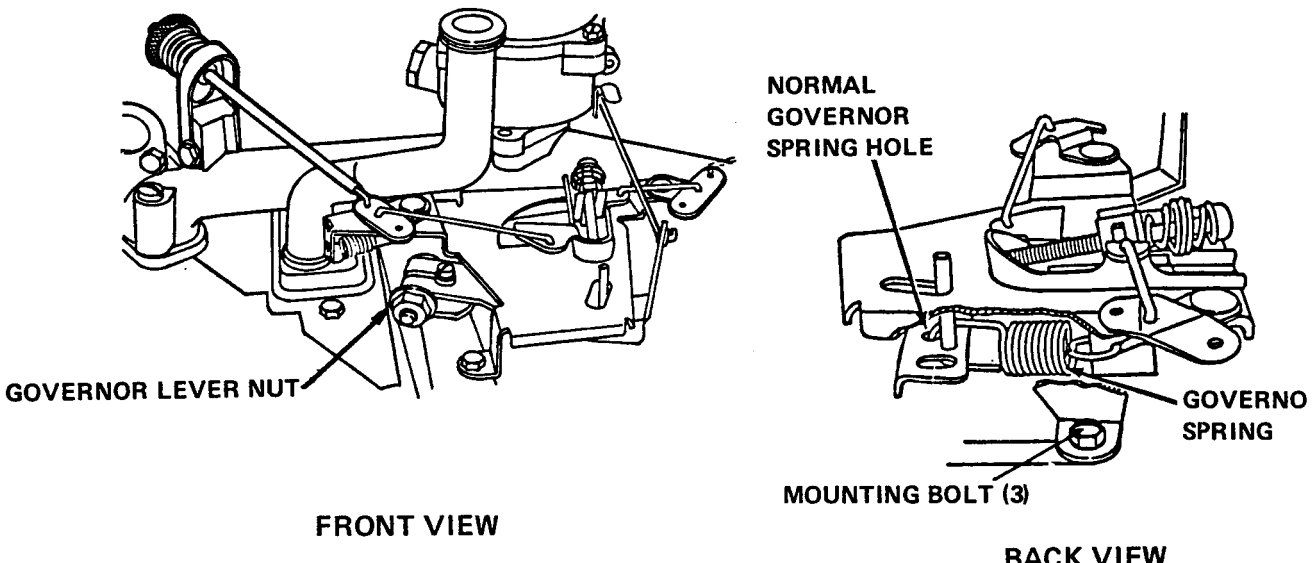
Item No.	Interval			Item to be Inspected procedure
	W	M	H	
5	•			 <p>Engine. Check for leaks at engine base gasket, crankcase cover gaskets, and breather assembly gaskets. Check for loose mounting bolts. If needed, tighten engine base, crankcase cover, and breather assembly mounting bolts.</p>
6		•		 <p>Compressor. Start up engine (para 2-8b). Check compressor for unusual noise, leaks, irregular pulley motion, loose mounting bolts and belt adjustment. If mounting bolts loose, adjust belt (para 4-21). If other problem exists, notify Direct Support maintenance.</p>

Table 4-1. Unit Prevent Maintenance Checks and Services (Cont)

W - Weekly

M - Monthly

H - Hourly

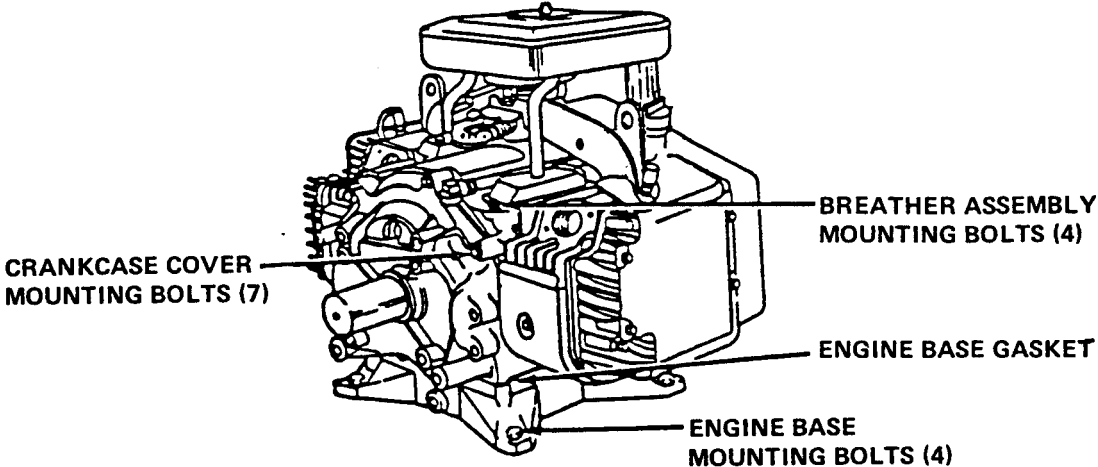
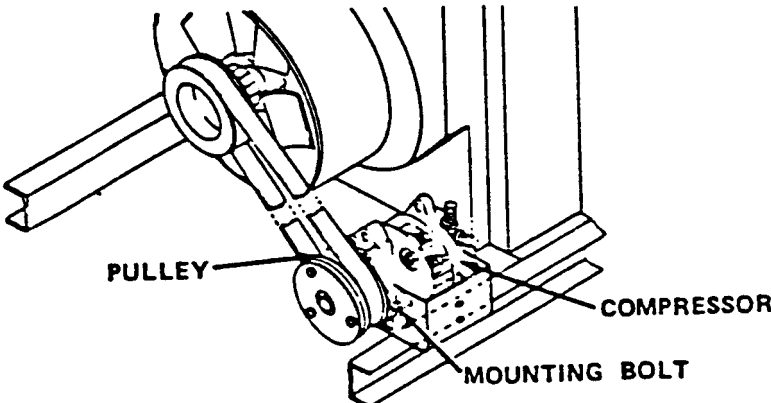
Item No.	Interval			Item to be Inspected Procedure
	W	M	H	
7		●		 <p>Water Pump. Check for cracks, leaks, and loose mounting bolts. If mounting bolts loose, adjust bolts (para 4-20). Replace water pump if needed (para 4-20). Check high temperature thermal switch for damage. Replace if damaged.</p>

Table 4-1. Unit Prevent Maintenance Checks and Services (Cont)

W - Weekly

M - Monthly

H - Hourly

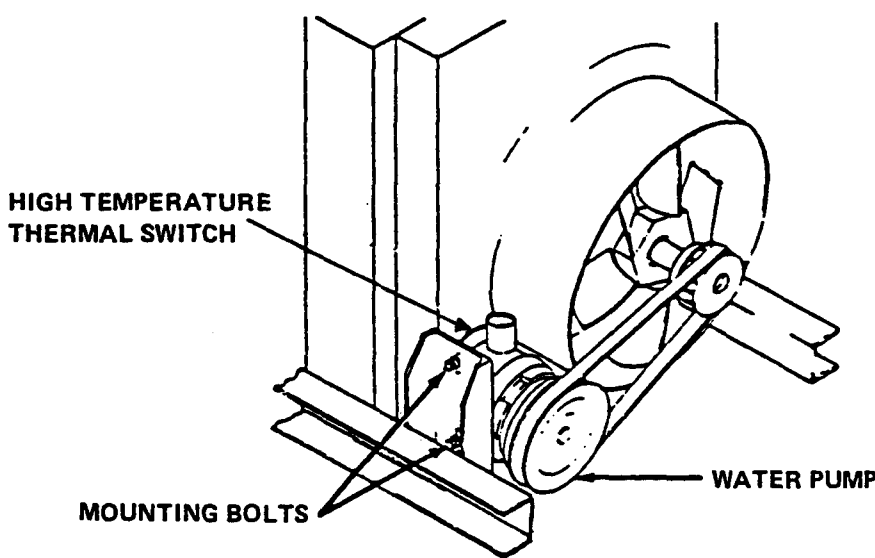
Item No.	Interval			Item to be Inspected Procedure
	W	M	H	
8		•	200	
				<p>Spark Plugs. Remove and clean after 200 hours of operation or monthly, whichever comes first. Check for cracks, burning, fouling and regap as necessary. Replace if cracked, burnt, or fouled (para 4-30).</p>
9		•		
				<p>Condenser. Clean condenser by removing any collected dirt and debris.</p>

Table 4-1. Unit Prevent Maintenance Checks and Services (Cont)

W - Weekly

M - Monthly

H - Hourly

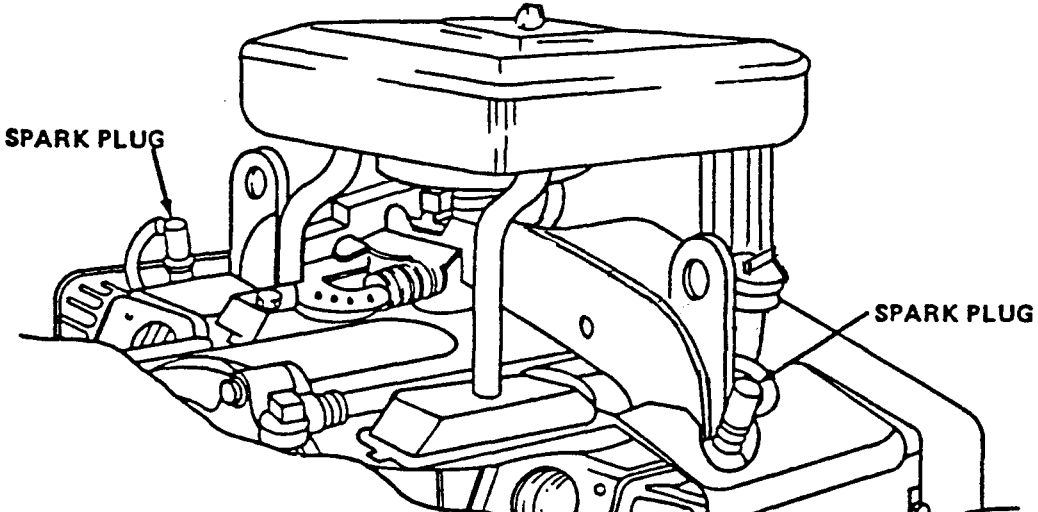
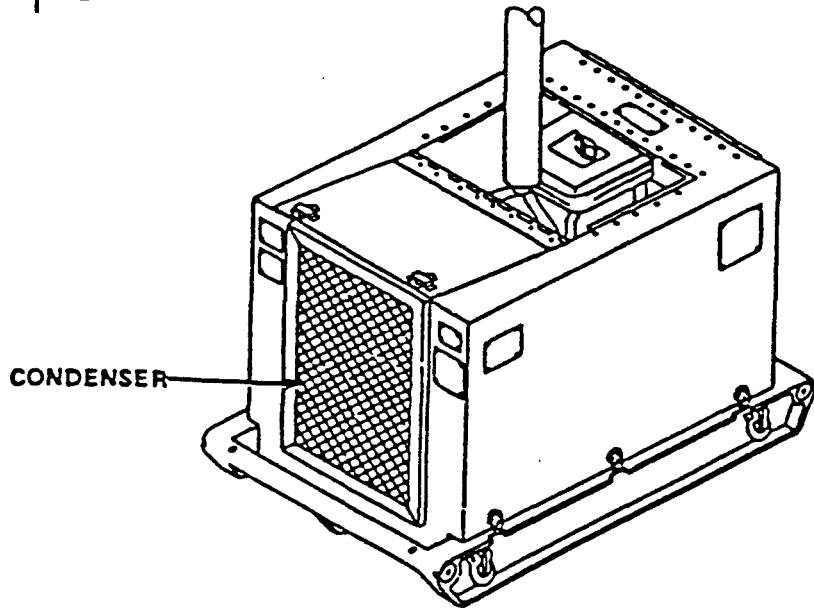
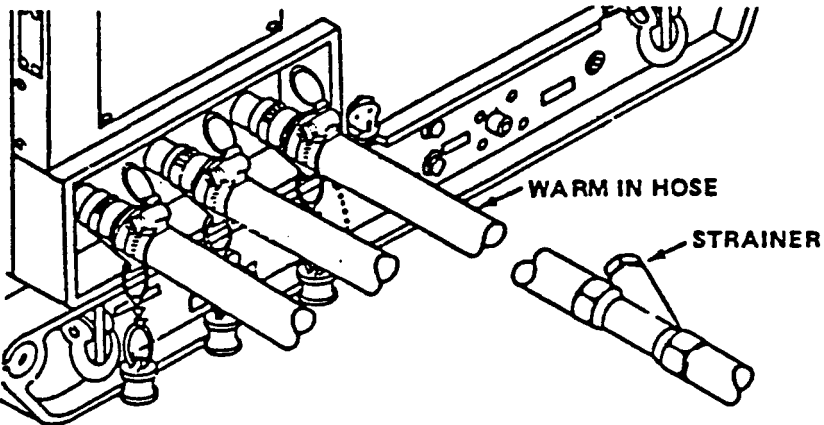
Item No.	Interval			Item to be Inspected procedure
	W	M	H	
10		•		 <p>Strainer. Inspect and clean strainer in WARM IN HOSE .</p>

Section V. UNIT TROUBLESHOOTING

4-13. TROUBLESHOOTING . Table 4-2, Unit Troubleshooting, lists common malfunctions which may be found during normal operation or during an inspection, check procedure, or scheduled testing. Perform the tests/inspections and corrective actions in order listed. This manual cannot list all malfunctions that may occur or list all tests/inspections and corrective actions. If a malfunction occurs that is not listed or covered in corrective action, notify your supervisor.

Table 4-2. Unit Troubleshooting

MALFUNCTION	TEST OR INSPECTION	CORRECTIVE ACTION
1. ENGINE FAILS TO START WITHOUT EXTERNAL POWER OR CRANKS BUT FAILS TO START WITH EXTERNAL POWER.	Step 1. Inspect choke for proper operation.	Adjust choke as required (para 4-27).
	Step 2. Check fuel line and fuel filter for damage or blockage.	Repair fuel line or replace fuel filter (para 4-43) .
	Step 3. Check spark plugs for gap, fouling or damage.	Clean, adjust or replace spark plugs (para 4-30).
	Step 4. Check carburetor for damage or blockage.	Replace carburetor (para 4-27).
	Step 5. Test toggle switch S3 (para 4-18) and pneumatic timer switch (S8) (para 4-19).	Replace toggle switch S3 (para 4-18) or pneumatic timer switch (S8) (para 4-19).
	Step 6. Test armature group (para 4-31).	Replace armature group (para 4-31).
	Step 7. Check engine compression (para 4-25). Should not vary more than 25 percent between cylinders.	If greater than 25 percent variance, notify your supervisor.

Table 4-2. Unit Troubleshooting (Cont)

MALFUNCTION	TEST OF INSPECTION	CORRECTIVE ACTION
-------------	--------------------	-------------------

2. ENGINE FAILS TO CRANK WITH EXTERNAL POWER.

- Step 1. Check for proper voltage to 12 VOLT INPUT FOR STARTING connection.
Obtain proper voltage (12 volts).
- Step 2. Check for proper voltage (12 volts) at back of 12 VOLT INPUT FOR STARTING connection (para 4-41).
If voltage incorrect, replace connection (para 4-41).
- Step 3. Test starter button S7 and cables for voltage (para 4-29).
Replace battery cable or starter button S7 (para 4-29).
- Step 4. Check for proper voltage (12 volts) at starter (para 4-33).
Replace starter cable or starter (para 4-33).
- Step 5. Check ring gear for damage (para 4-34).
Replace flywheel (para 4-34). If problem not corrected, notify your supervisor.

3. ENGINE STOPS SUDDENLY

- Step 1. Inspect inline fuel filter for restricted gas flow.
Replace with clean filter (para 4-43).

Table 4-2. Unit Troubleshooting (Cont)

MALFUNCTION	TEST OR INSPECTION	CORRECTIVE ACTION
	Step 2.	Test high temperature thermal switch for continuity (para 4-38). Replace switch (para 4-37).
	Step 3.	Test high and low pressure switches and low temperature thermal switch for continuity (para 4-35, 4-36, and 4-40). If any switch fails test, notify your supervisor.
4.	LOW ENGINE SPEED.	
	Step 1.	Check for fouled spark plug(s), grounded or open plug wire(s) . Clean or replace spark plug(s) (para 4-30) or replace armature assembly (para 4-31).
	Step 2.	Inspect muffler for restriction or damage. Remove restriction or replace muffler as necessary.
	Step 3.	Check operation of governor controls (para 4-28). Adjust or replace governor controls (para 4-28).
	Step 4.	Check for water in fuel supply. Replace with fresh fuel.
	Step 5.	Inspect for seized compressor. Notify Direct Support.
5.	ENGINE SMOKES EXCESSIVELY OR LEAKS OIL.	
	Step 1.	Check oil level. Drain excess oil.
	Step 2.	Check breathers for blockage (para 4-45). Replace blocked or damaged breathers.

Table 4-2. Unit Troubleshooting (Cont)

MALFUNCTION	TEST OR INSPECTION	CORRECTIVE ACTION
6. PRODUCT WATER NOT COOL.	Step 1. Check for loose or broken belt(s).	Adjust or replace belt(s) (para 4-20 and 4-21).
	Step 2. Check fan for loose or missing blades.	Replace fan assembly (para 4-22).
	Step 3. Inspect water pump for impeller or bearing failure.	Repair or replace water pump as necessary (para 4-37) .
	Step 4. Check engine speed (MALFUNCTION 4).	If problem not corrected, notify your supervisor.
7. LOW OUTLET WATER PRESSURE.	Step 1. Check for loose or broken water pump drivebelt.	Adjust or replace water pump drivebelt (para 4-20) .
	Step 2. Check water pump for proper operation.	Replace water pump (para 4-37).
	Step 3. Check operation of relief valve.	Adjust relief valve (para 4-39).
	Step 4. Check engine speed (MALFUNCTION 4).	If problem not corrected, notify your supervisor.

Section VI. UNIT MAINTENANCE PROCEDURES

INDEX

	PARA
General	4-14
Housing Replacement	4-15
Housing Repair	4-16
Wiring Harness Repair	4-17
Toggle Switch S3 Replacement	4-18
Pneumatic Timer Switch S8	4-19
Water Pump Drivebelt Replacement	4-20
Compressor Drivebelt Replacement	4-21
Fan Assembly Replacement	4-22
Centrifugal Clutch Replacement	4-23
Exhaust System Replacement	4-24
Engine Assembly Replacement	4-25
Air Cleaner Elements Replacement	4-26
Carburetor and Intake Manifold Replacement	4-27
Governor Control Replacement	4-28
Starter Panel Assembly Replacement	4-29
Spark Plugs Replacement	4-30
Armature Group Replacement/Repair	4-31
Dipstick and Tube Assembly Replacement	4-32
Starter Replacement	4-33
Flywheel and Ring Gear Assembly Replacement/Repair	4-34
High Pressure Switch Continuity Test	4-35
Low Pressure Switch Continuity Test	4-36
Water Pump Replacement	4-37
High Temperature Thermal Switch Replacement	4-38
Relief Valve Adjustment	4-39
Low Temperature Thermal Switch Test	4-40
Starting Connection Assembly Replacement	4-41
Skid Repair (Carrying Handle)	4-42
Fuel Hose Repair	4-43
Water Hose Repair	4-44
Breather Assembly Replacement	4-45

4-14. GENERAL

Scope. This section contains Unit maintenance instructions authorized by the Maintenance Allocation Chart (MAC), Appendix B, and by the Source, Maintenance, and Recoverability (SMR) coded items to support the water chiller.

4-15. HOUSING REPLACEMENT.

DESCRIPTION

This task covers: Removal, Installation.

INITIAL SETUP

Equipment
Condition

<u>Para</u>	<u>Condition Description</u>
2-8	Engine stopped.

Personnel Required:

Two to lift housing.

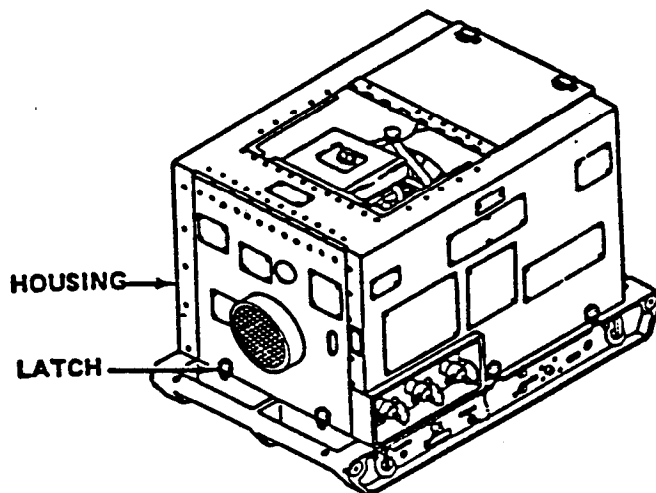

REMOVAL

1. Turn nine latches left to lengthen. Pull away from slot. Turn right to shorten to prevent catching on slot.
2. With one person at each end, slowly lift housing. Tilt as needed to clear engine and condenser. Remove housing.

INSTALLATION

1. With one person at each end, slowly lower housing over water chiller. Tilt as needed to clear engine and condenser.
2. Fasten nine latches.

4-16. HOUSING REPAIR.

DESCRIPTION

This task covers repair only.

INITIAL SETUP

Equipment
Condition

<u>Para</u>	<u>Condition Description</u>
2-8	Engine stopped.

Tools

- Tool Kit, General
Mechanic's, item 1,
Appendix B
- Drill, portable, 1/4 in.
(5130-00-807-3009)
item 3, Appendix B
- Drill set, twist
(5133-00-293-098)
item 3, Appendix B
- Riveter, Blind, Hand
(5120-00-017-2849)
item 10, Appendix B.

Materials/Parts:

- Rivets MS20470AD4-6
- Rivets MS20426AD4-6
- Rivets 13214E3789-3
- Adhesive, item 4, Appendix E
- Rubber strip, para F-2
- Primer coating, item 21, Appendix E

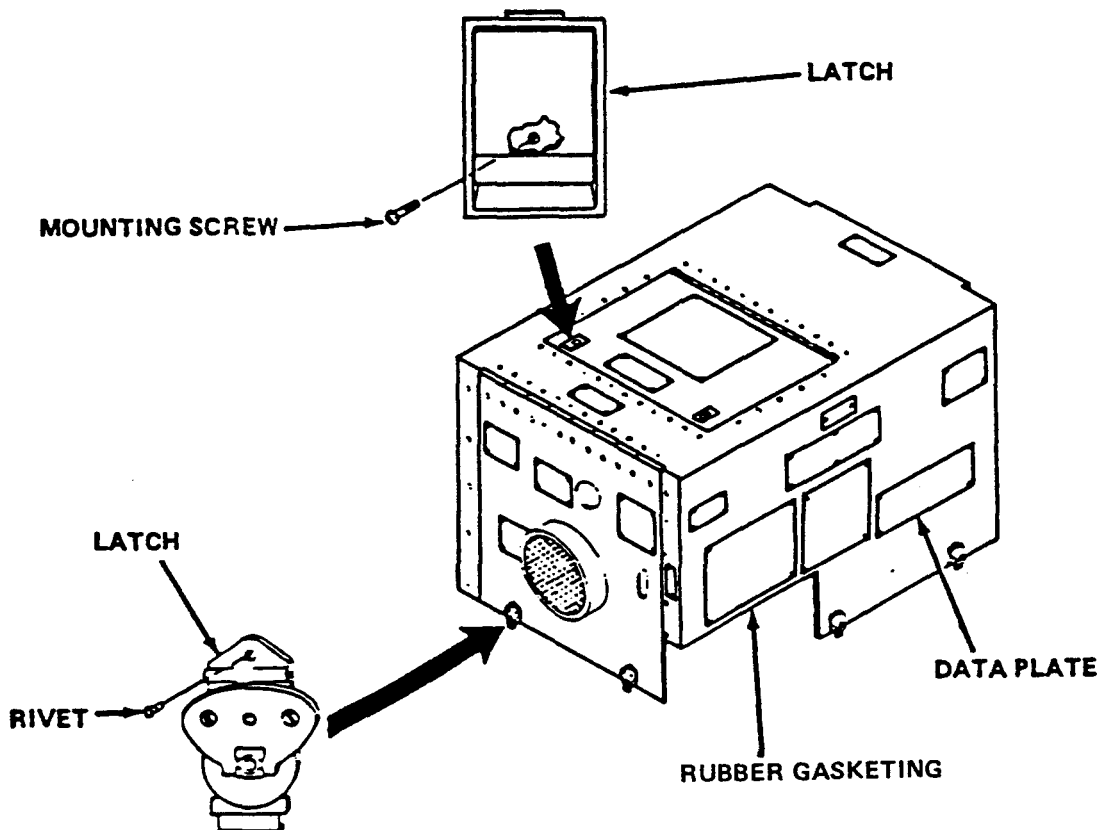

4-16. HOUSING REPAIR (CONT)

REPLACEMENT OF SIDE LATCHES AND RIVETS

1. Drill out rivets. Remove latch.
2. Install latch.
3. Coat stem of rivet with primer paint.
4. Install rivet.

REPLACEMENT OF TOP LATCHES

1. Hold top latch in open position. Remove mounting screw and bracket. Remove top latch.
2. Hold top latch in open position. Install mounting screw through top latch into bracket.

REPLACEMENT OF DATA PLATES

1. Drill out existing rivets on data plate. Remove data plate from housing.
2. Install data plate on housing. Aline mounting holes.
3. Install pop rivets in mounting holes.

REPLACEMENT OF RUBBER STRIP

1. Remove existing rubber strip.
2. Cut new rubber to correct length. Apply adhesive to one side of rubber strip and to housing. Install rubber strip with adhesive side against housing. Trim any excess.

4-17. WIRING HARNESS REPAIR.

DESCRIPTION

This task covers: Testing and Repair

INITIAL SETUP

Equipment
Condition

Para	Condition Description
2-8	Engine stopped.
4-15	Housing

Tools

Tool Kit General
Mechanic's, item 1,
Appendix B
Multimeter, item 2,
Appendix B

Materials/Parts:

Wire, para F-3.
Tubing, para F-4.

ELECTRICAL DIAGRAM

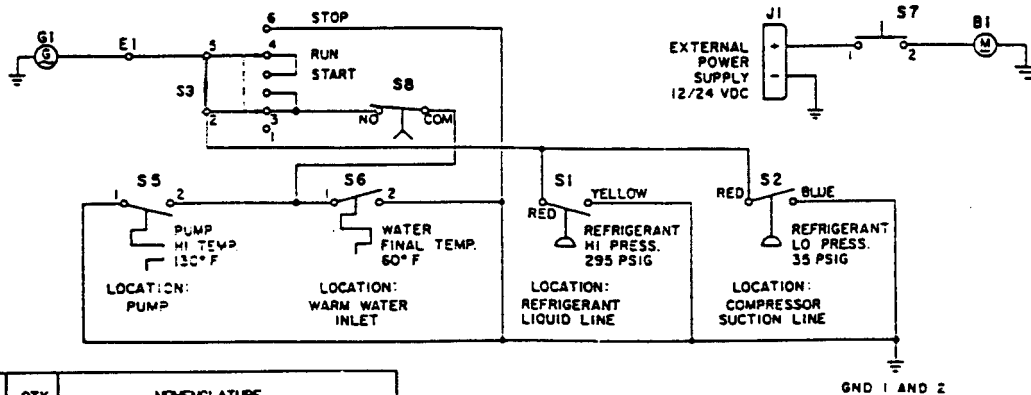

REF DES	QTY	NOMENCLATURE
B1	1	STARTER MOTOR
E1	1	TERMINAL
G1	1	MAGNET
J1	1	SLAVE RECEPTACLE
S1	1	SWITCH HIGH PRESSURE
S2	1	SWITCH LOW PRESSURE
S3	1	SWITCH DPDT
S5	1	SWITCH THERMAL, HIGH TEMPERATURE
S6	1	SWITCH THERMAL, FINAL TEMPERATURE
S7	1	SWITCH STARTER
S8	1	SWITCH PNEUMATIC TIMER

NOTE

Due to the nature of operation, the pneumatic timer switch S8 operates opposite from normal. Terminal NO is closed and terminal NC is open.

4-17. WIRING HARNESS REPAIR (CONT)

TESTING

1. Disconnect prepare multimeter for continuity test.
2. Disconnect one end of wire. Place red lead on one end of wire section to be tested. Place black lead on other end of wire section to be tested.
3. Multimeter should display less than 1 ohm. If it displays more than 1 ohm, replace wire.

REPAIR

1. Unwrap harness cover as needed. Remove damaged wire from wiring harness.
2. Cut correct length of wire from bulk wire. (See para F-3). Crimp terminal to each end of wire.
3. Install wire in wiring harness. Rewrap cover as needed.

4-18. TOGGLE SWITCH S3 REPLACEMENT.

DESCRIPTION

This task covers: Testing, Removal, and Installation

INITIAL SETUP

Equipment
Condition

<u>Para</u>	<u>Condition Description</u>	<u>Tools</u>
2-8	Engine stopped.	Tool Kit, Generals Mechanic, item 1,
4-15	Housing removed.	Appendix B Multimeter, item 2,

Materials/Parts:

Tags, item 32, Appendix E

4-18. TOGGLE SWITCH S3 REPLACEMENT (CONT)

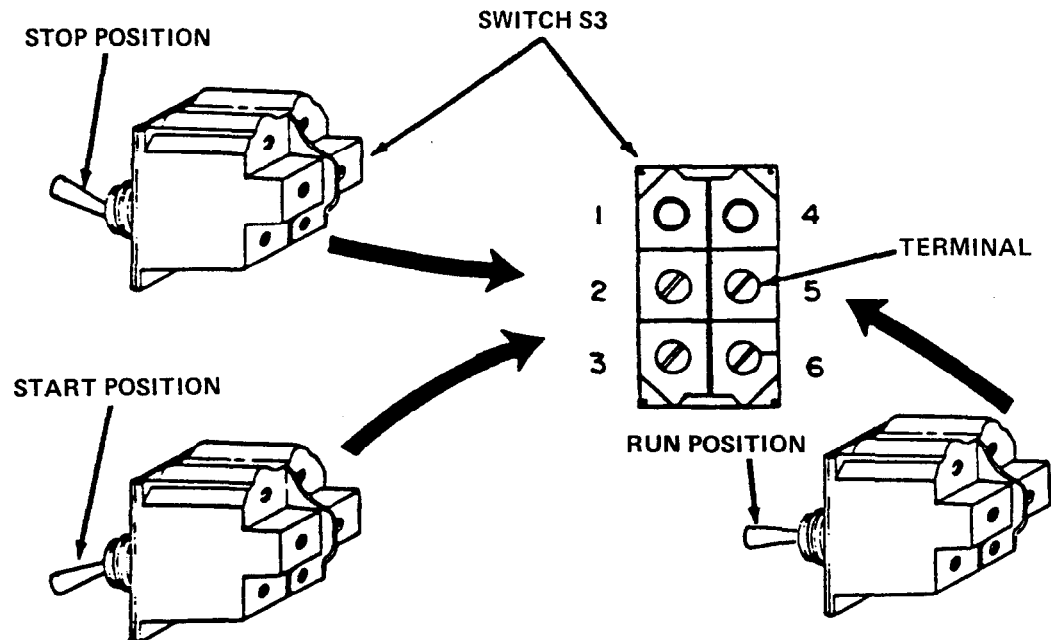
**TESTING**

1. Tag and remove six wires from back of switch.
2. Prepare multimeter for continuity test. Place switch S3 in RUN position. Place red lead on terminal 2 and black lead on terminal 3. Measure and record continuity. Place red lead on terminal 4 and black lead on terminal 5. Measure and record continuity.
3. If multimeter does not show continuity during either test, replace switch.
4. Place switch S3 in STOP position. Place red lead on terminal 5 and black lead on terminal 6. Measure and record continuity. Place red lead on terminal 2 and black lead on terminal 3. Measure and record continuity.
5. If multimeter does not show continuity during either test, replace switch.
6. Place switch S3 in START position. Place red lead on terminal 1 and black lead on terminal 2. Measure and record continuity. Place red lead on terminal 4 and black lead on terminal 5. Measure and record continuity.
7. If multimeter does not show continuity during either test, replace switch.
8. If switch passes test, install six wires on back of switch. Remove tags.

4-18. TOGGLE SWITCH S3 REPLACEMENT (CONT)

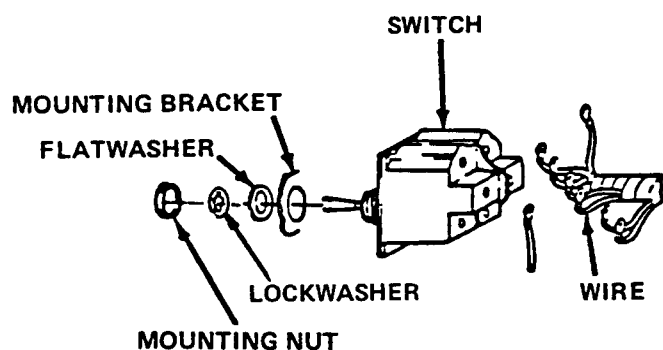

REMOVAL

1. Tag and remove six wires from back of switch.
2. Remove mounting nut, lockwasher, and flatwasher.
3. Remove switch from mounting bracket.

INSTALLATION

1. Install switch in mounting bracket.
2. Install flatwasher, lockwasher and mounting nut.
3. Install six wires on back of switch. Remove tags.

4-19. PNEUMATIC TIMER SWITCH S8 REPLACEMENT.

DESCRIPTION

This task covers: Testing, Removal, and Installation

INITIAL SETUP

Equipment
Condition

<u>Para</u>	<u>Condition Description</u>	<u>Tools</u>
2-8	Engine stopped.	Tool Kit, General Mechanic's, item 1, Appendix B Multimeter, item 2, Appendix B
4-15	Housing removed.	

Materials/Parts:

Tags, item 32, Appendix E

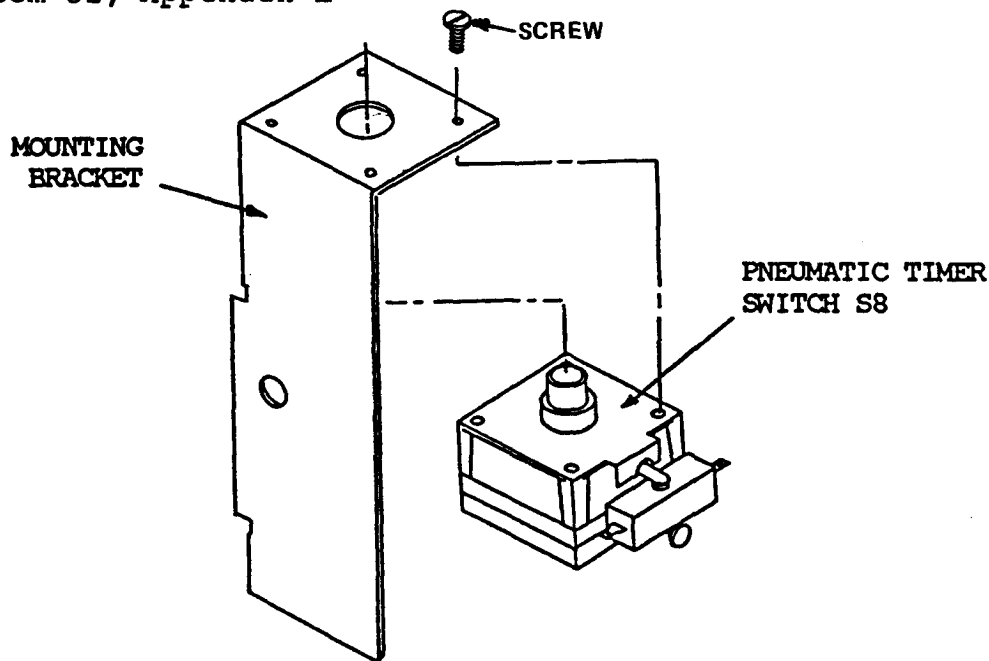

TESTING

1. Tag and remove three wires from switch.

NOTE

Because of the pneumatic timer switch assembly the NO and NC designations are REVERSED.

2. Prepare multimeter for continuity test. Place red lead on terminal NO and black lead on terminal COM.

4-19. PNEUMATIC TIMER SWITCH S8 REPLACEMENT (CONT)

- 3. Test
 - (a) Measure resistance. Multimeter should show less than 1 ohm.
 - (b) Press button and measure resistance. Resistance should be infinity. After approximately 45 seconds, the resistance should be less than 1 ohm. If resistance is not correct, replace pneumatic timer switch.
- 4. If switch passes test, install three wires on switch. Remove tags.

REMOVAL

- 1. Tag and remove three wires from switch.
- 2. Remove mounting screws.
- 3. Remove switch from mounting bracket.

INSTALLATION

- 1. Install switch in mounting bracket.
- 2. Install mounting screws.
- 3. Install three wires on switch. Remove tags.

4-20. WATER PUMP DRIVEBELT REPLACEMENT.

DESCRIPTION

This task covers: Inspect, Removal, Installation, and Adjustment

INITIAL SETUP

<u>Equipment Condition Para</u>	<u>Condition Description</u>	<u>Tools</u>
2-8	Engine stopped.	Tool Kit, General
4-15	Housing removed.	Mechanic's, item 1, Appendix B

4-20. WATER PUMP DRIVEBELT REPLACEMENT (CONT)

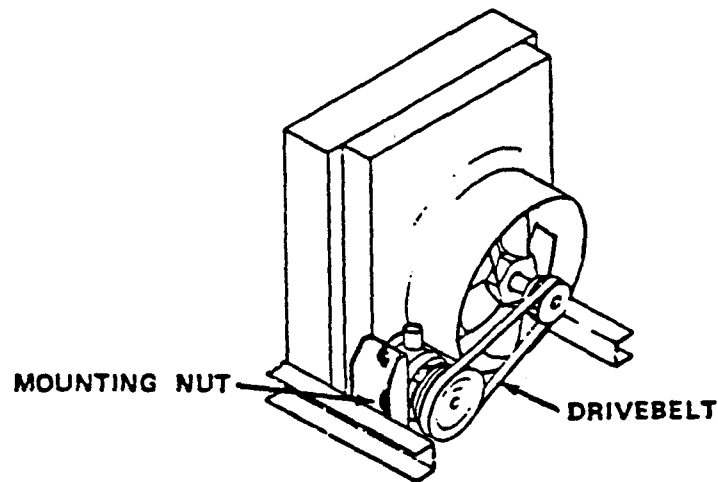
**INSPECTION**

1. Look closely at belt for cracking, missing teeth and/or frayed areas. Replace any belt in poor condition.
2. If water pump will not adjust to proper tension replace belt.
3. With belt removed, inspect pulley for wear and damage. If pulley worn or damaged, notify Direct Support.

REMOVAL

1. Loosen two mounting nuts.
2. Lift water pump, sliding mounting bolts up in holes.
3. Remove drivebelt from water pump pulley and pulley drive. Lift over fan to remove.

INSTALLATION

Install drivebelt on pulley drive and water pump pulley.

ADJUSTMENT

1. Push down on water pump, sliding bolts down in holes.
2. Adjust drivebelt to proper tension, about 1/4-inch (2/3-centimeter) deflection at center of belt.
3. Tighten mounting nuts.

4-21. COMPRESSOR DRIVEBELT REPLACEMENT.

DESCRIPTION

This task covers: Inspection, Removal, Installation, and Adjustment

INITIAL SETUP

Equipment
Condition

<u>Para</u>	<u>Condition Description</u>	<u>Tools</u>
2-8	Engine stopped.	Tool Kit, General Mechanic's, item 1, Appendix B
4-15	Housing removed.	
4-20	Water pump drivebelt removed.	

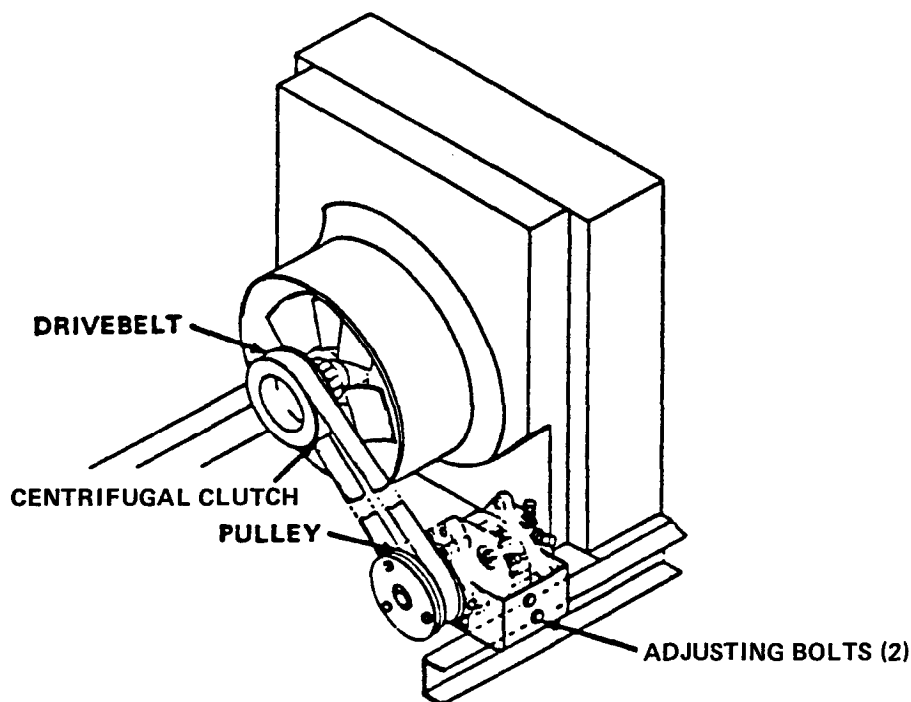

INSPECTION

1. Look closely at belt for cracking, missing teeth and/or frayed areas. Replace any belt in poor condition.
2. If compressor will not adjust to proper tension replace belt.
3. With belt removed, inspect pulley for wear and damage. If pulley is worn or damaged, notify Direct Support.

4-21. COMPRESSOR DRIVEBELT REPLACEMENT (CONT)

REMOVAL

1. Loosen two bracket mounting bolts.
2. Lift compressor, sliding mounting bracket up.
3. Remove drivebelt from compressor pulley and pulley drive. Lift belt over fan to remove.

INSTALLATION

Install drivebelt on pulley drive and compressor pulley.

ADJUSTMENT

1. Push down on compressor., sliding mounting bracket down.
2. Adjust drivebelt to proper tension, about 1/4-inch (2/3-centimeter) deflection at center of belt.
3. Tighten two adjusting bolts.
4. Install water pump drivebelt (parag 4-20).

4-22. FAN ASSEMBLY REPLACEMENT.

DESCRIPTION

This task covers: Removal and Installation

INITIAL SETUP

Equipment
Condition

<u>Para</u>	<u>Condition Description</u>	<u>Tools</u>
2-8	Engine stopped.	Tool Kit, General Mechanic's, item 1, Appendix B
4-15	Housing removed.	
4-25	Engine removed.	

Materials/Parts:

Lockwasher MS35338-140
Lockout MS172238

4-22. FAN ASSEMBLY REPLACEMENT (CONT)

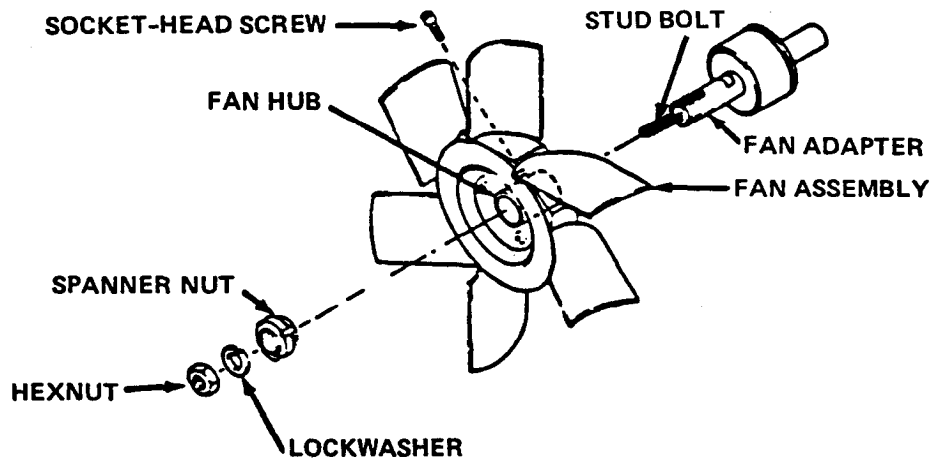

REMOVAL

1. Remove hexnut and lockwasher from studbolt.
2. Remove spanner nut from studbolt.
3. Loosen socket-head screw on back of fan hub.
4. Remove fan assembly.

INSTALLATION

1. Install fan assembly on fan adapter.
2. Install spanner nut on studbolt.
3. Align socket head screw over flat area on fan adapter.
4. Tighten socket-head screw on back of fan adapter.
5. Install lockwasher and hexnut on stud and bolt.
6. Install engine (para 4-25).

4-23. CENTRIFUGAL CLUTCH REPLACEMENT.

DESCRIPTION

This task covers: Removal, Inspection, and Installation

INITIAL SETUP

Equipment
Condition

<u>Para</u>	<u>Condition Description</u>	<u>Tools</u>
2-8	Engine stopped.	Tool Kit, General Mechanic's, item 1, Appendix B Puller Kit, Mechanical item 2, Appendix B
4-15	Housing removed.	
4-25	Engine removed.	
4-22	Fan assembly removed.	

NOTE

Fan adapter and water pump pulley drive are a press-fit assembly.

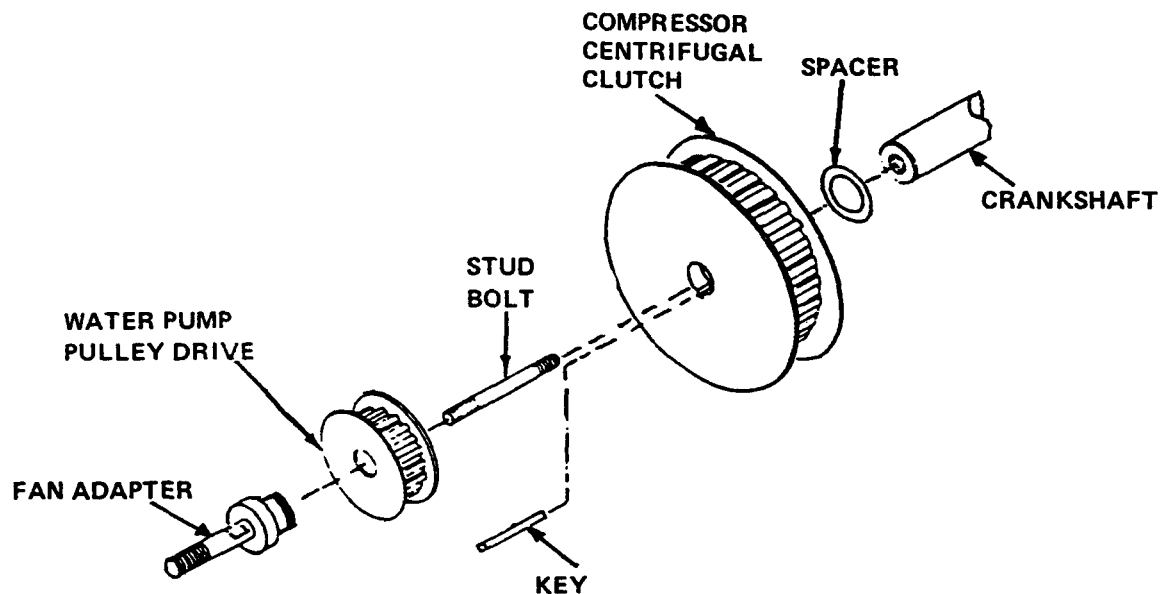

4-23. CENTRIFUGAL CLUTCH REPLACEMENT (CONT)

REMOVAL

1. Remove fan adapter and water pump pulley drive.
2. Remove centrifugal clutch.
3. Unscrew threaded studbolt from end of engine crankshaft.
4. Remove key.
5. Remove spacer from crankshaft.

INSPECTION

1. With belt removed, inspect water pump pulley drive and centrifugal clutch for wear and damage.
2. Replace water pump drive if worn or damaged.
3. Replace centrifugal clutch if worn or damaged.

INSTALLATION

1. Thread studbolt into crankshaft.
2. Place spacer on crankshaft.
3. Place locking key in keyway on crankshaft.
4. Place centrifugal clutch on crankshaft with puller holes away from engine. Aline centrifugal clutch with locking key and push on.
5. Install water pump pulley drive and fan adapter on end of crankshaft.
6. Install fan assembly (para 4-22).
7. Install engine (para 4-25).

4-24. EXHAUST SYSTEM REPLACEMENT.

DESCRIPTION

This task covers: Removal and Installation

INITIAL SETUP

Equipment
Condition

<u>Para</u>	<u>Condition Description</u>	<u>Tools</u>
2-8	Engine stopped.	Tool Kit, General Mechanic's, item 1, Appendix B Wrench, torque (5120-00-640-6364) item 2, Appendix B
4-15	Housing removed.	

Materials/Parts:

Lockwasher MS35338-139

REMOVAL

WARNING

To prevent burns, DO NOT try to remove muffler until it cools down.

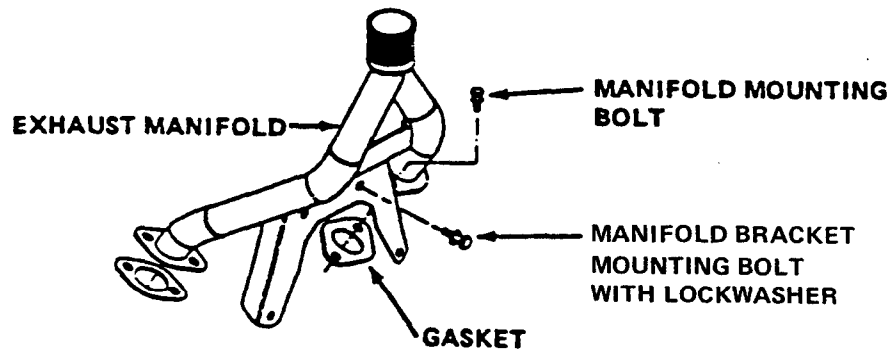

1. Remove muffler.
2. Remove four exhaust manifold mounting bolts and lockwashers. Remove four exhaust manifold bracket mounting bolts.
3. Remove exhaust manifold and two gaskets. Discard gaskets.

4-24. EXHAUST SYSTEM REPLACEMENT (CONT)

INSTALLATION

1. Install two exhaust manifold gaskets on engine.
2. Install exhaust manifold on gaskets.

CAUTION

To prevent damage to manifold, be sure to install all bolts by hand before tightening. Tighten in order listed.

3. Install four exhaust manifold mounting bolts. Hand-tighten.
4. Install four exhaust manifold bracket mounting bolts and lockwashers. Hand-tighten.
5. Tighten four exhaust manifold mounting bolts.
6. Torque four exhaust manifold bracket mounting bolts to 140 in. lb (15.8 Nm).
7. Install muffler assembly hand-tight.

4-25 . ENGINE ASSEMBLY REMOVAL.

DESCRIPTION

This task covers: Removal, Installation, and Testing

INITIAL SETUP

Equipment Condition Para	Condition Description	Tools
2-8	Engine stopped.	Tool Kit, General Mechanic's, item 1, Appendix B
4-15	Housing removed.	Tester, cylinder compression, item 2, Appendix B
4-30	Spark plugs removed (testing only).	

4-25. ENGINE ASSEMBLY REMOVAL (CONT)

Equipment
Condition

<u>Para</u>	<u>Condition Description</u>	<u>Tools</u>
4-1	Oil drained.	
4-21	Compressor drivebelt removed.	

Materials/Parts:

Strap, tiedown MS3367-1-9
Tags, item 32, Appendix E
Hose, para F-10

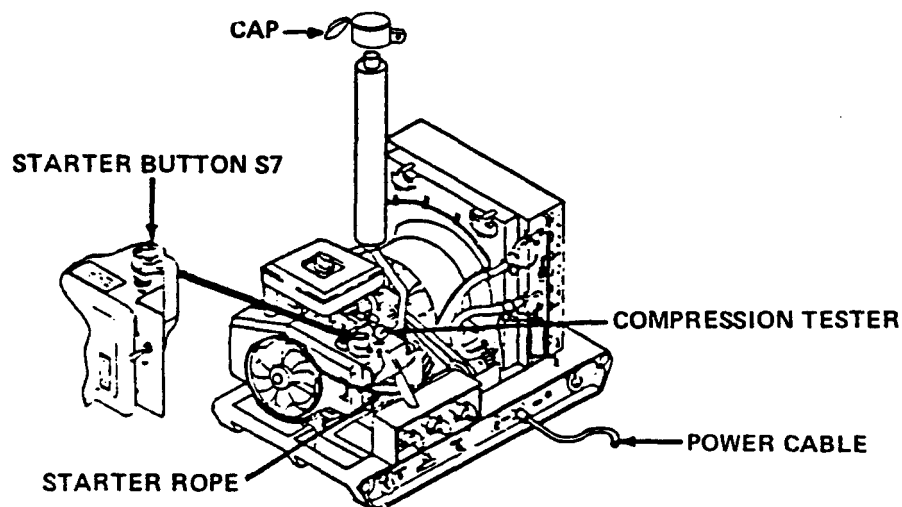

TESTING

1. Insert compression tester in one cylinder.
2. If electric power available, insert power cable in 12/24 VOLT INPUT FOR STARTING connection. Push starter button S7. If electric power unavailable, turn engine with starter rope.
3. Note compression displayed on tester.
4. Insert compression tester in other cylinder. Repeat steps 2 and 3.
5. Note compression displayed on tester. If there is more than a 25 percent difference between the two readings, notify Direct Support Maintenance.
6. Reinstall spark plugs (para 4-30).

4-25. ENGINE ASSEMBLY REMOVAL (CONT)

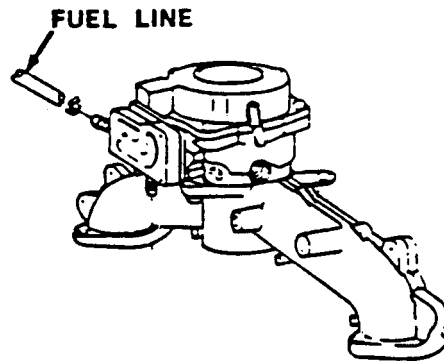

REMOVAL

1. Disconnect fuel line from carburetor connection.

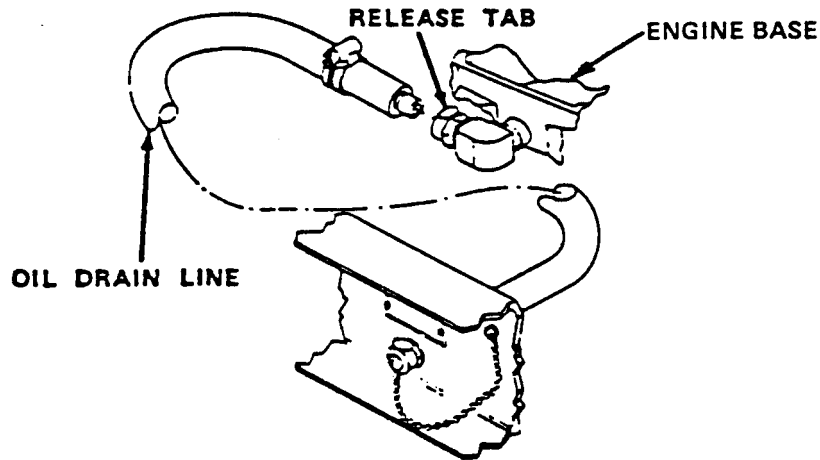

2. Press release tab. Disconnect crankcase oil drain line at base of engine.

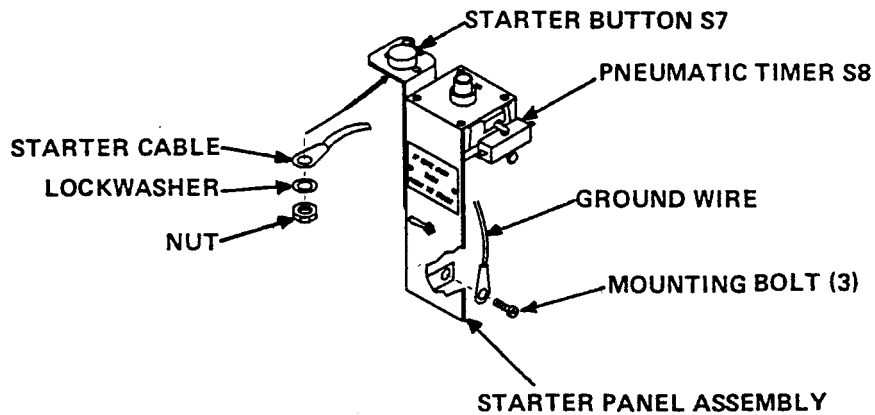

3. Remove three starter panel assembly mounting bolts and ground wire at GND1.

4-25. ENGINE ASSEMBLY REMOVAL (CONT)

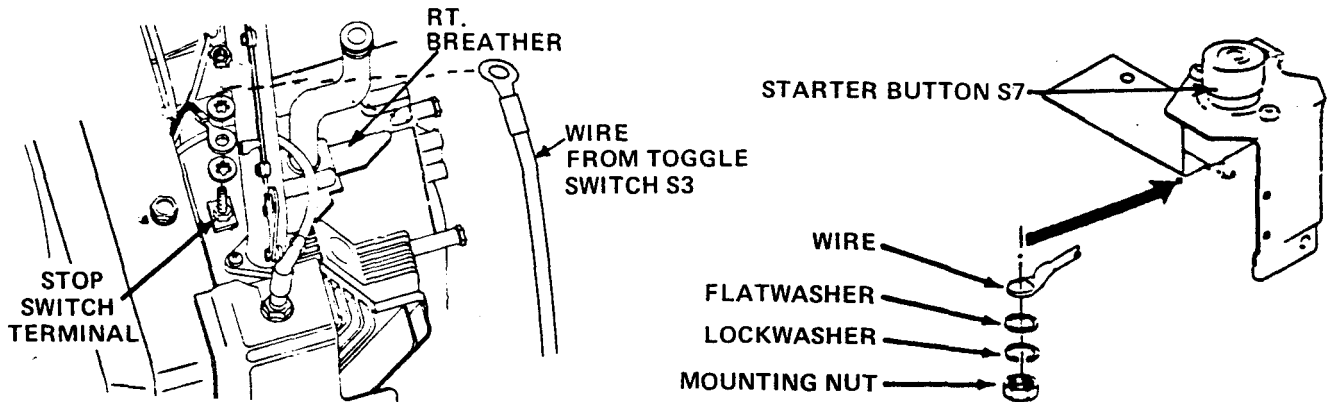

4. Remove wire from right breather assembly.

WARNING

To prevent electric shock, make sure power is disconnected from 12/24 VOLT INPUT FOR STARTING connection before performing this procedure.

5. Remove nut and lockwasher on starter button, S7 for starter cable. Remove starter cable.

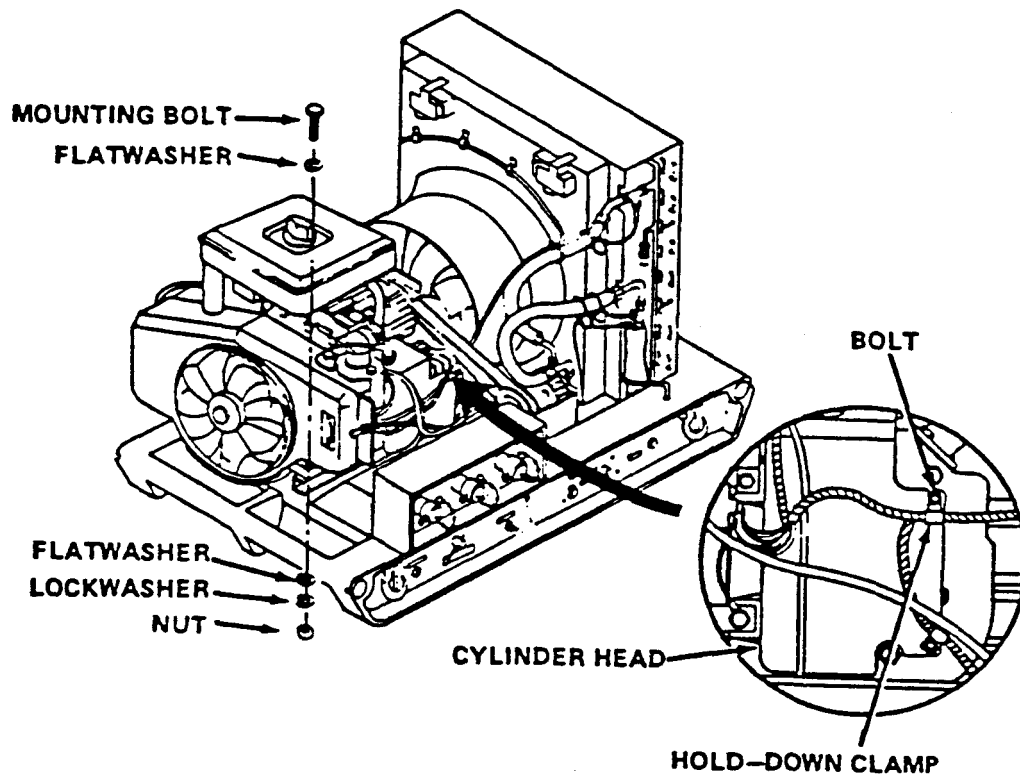

6. Remove two bolts and three wire hold-down clamps from cylinder head.

4-25. ENGINE ASSEMBLY REMOVAL (CONT)

7. Cut large tie strap holding power cable to oil drain elbow.
8. Remove four engine mounting bolts, nuts, lockwashers, eight flatwashers and ground cable from STARTER connection.

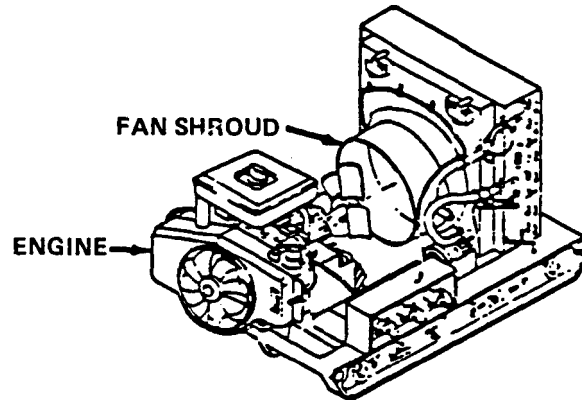

9. Slide engine back free of fan shroud and remove from water chiller base.
10. Remove fan assembly (para 4-22).
11. Remove centrifugal clutch (para 4-23).

INSTALLATION

1. Install centrifugal clutch (para 4-23).
2. Install fan assembly (para 4-22).
3. Place engine on water chiller base and slide forward to align mounting bolt holes.
4. Install four engine mounting bolts, nuts, lockwashers, eight flatwashers, and ground cable from STARTER connection

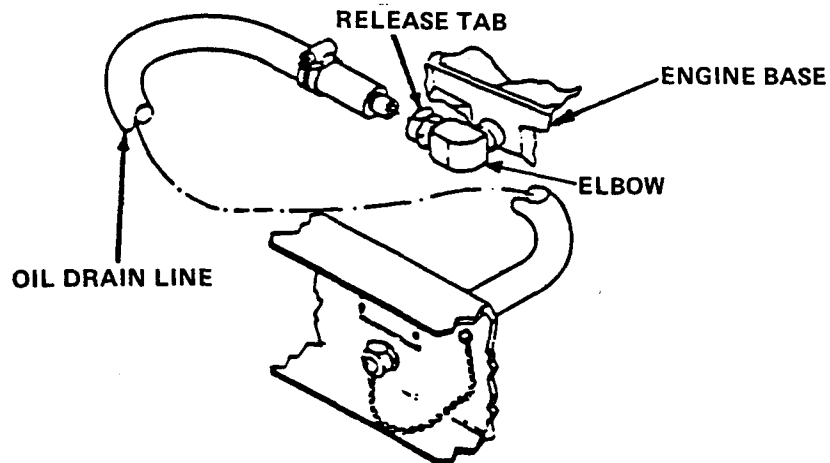

4-25. ENGINE ASSEMBLY REMOVAL (CONT)

5. Place new tie strap around ground cable from STARTER connection and elbow on engine base.
6. Press release tab. Connect engine oil drain line to engine base.

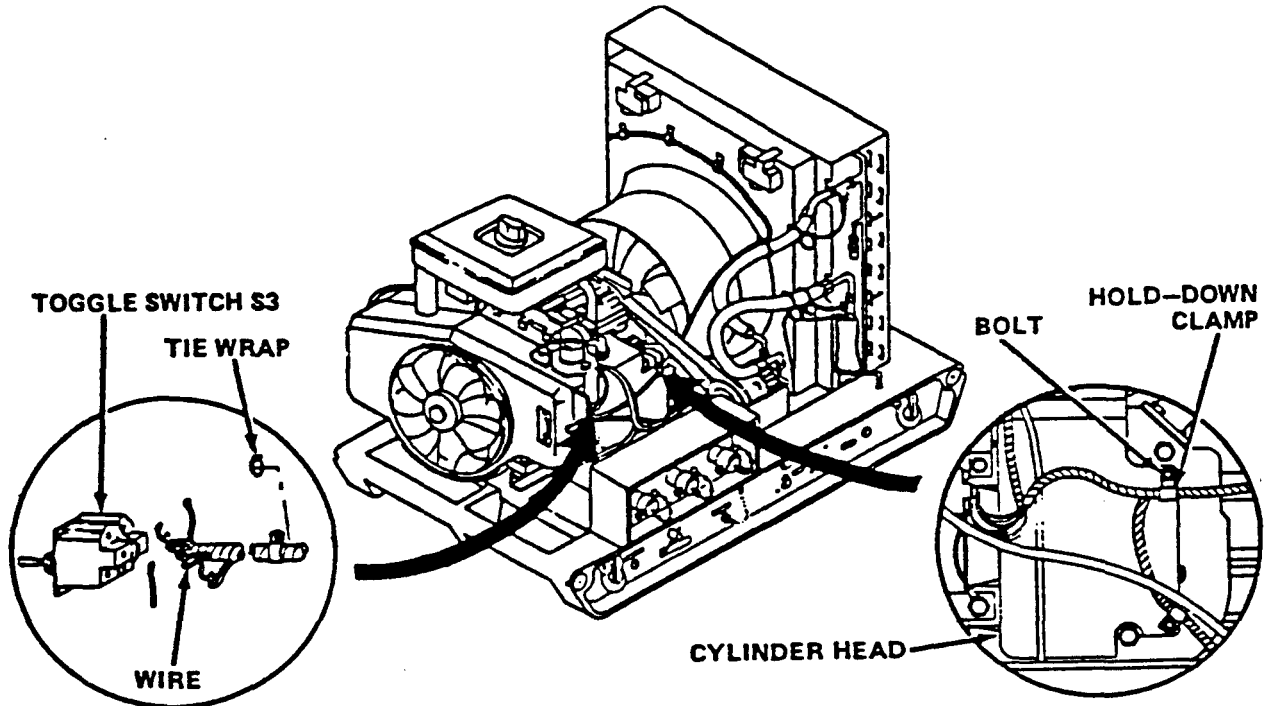

7. Install two bolts and three wire hold-down clamps on cylinder head assembly.

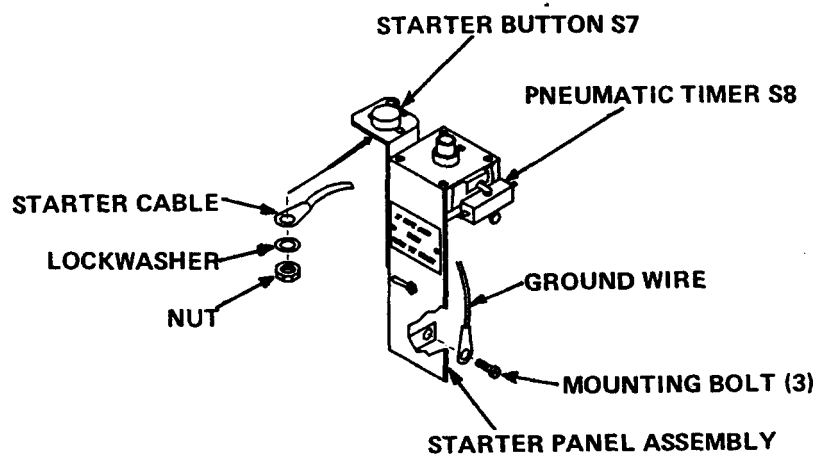

4-25. ENGINE ASSEMBLY REMOVAL (CONT)

8. Install starter cable to starter button S7. Install lockwasher and nut.
9. Install starter panel assembly.

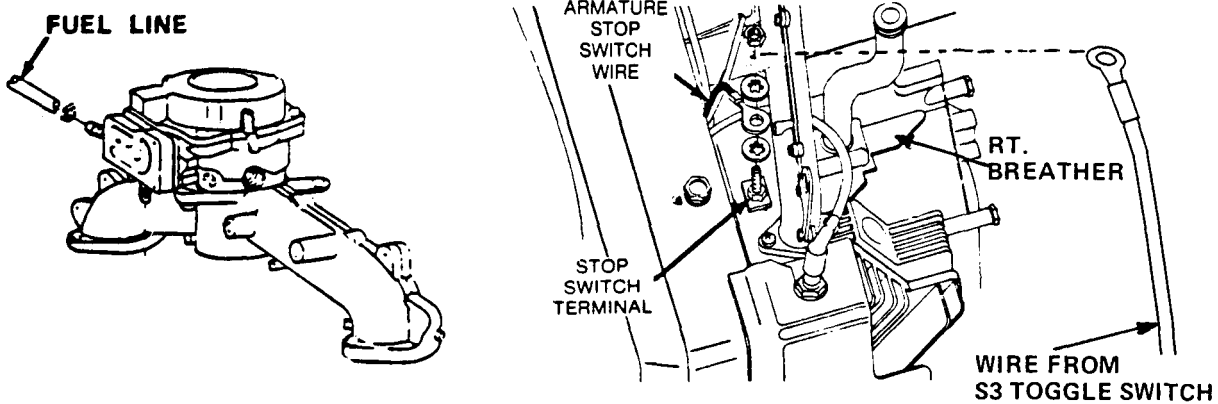

10. Attach wire from toggle switch S3 to terminal on
11. Install fuel hose to carburetor connection.
12. Fill engine with oil (para 4-1).
13. Install compressor drivebelt (para 4-21).
14. Install water pump drivebelt (para 4-20).

4-26. AIR CLEANER ELEMENTS REPLACEMENT.

DESCRIPTION

This task covers: Removal and Installation

INITIAL SETUP

Equipment Condition

<u>Para</u>	<u>Condition Description</u>	<u>Materials/Parts:</u>
2-8	Engine stopped.	Engine oil, item 17, Appendix E
4-15	Housing removed.	

4-26. AIR CLEANER ELEMENTS REPLACEMENT (CONT)

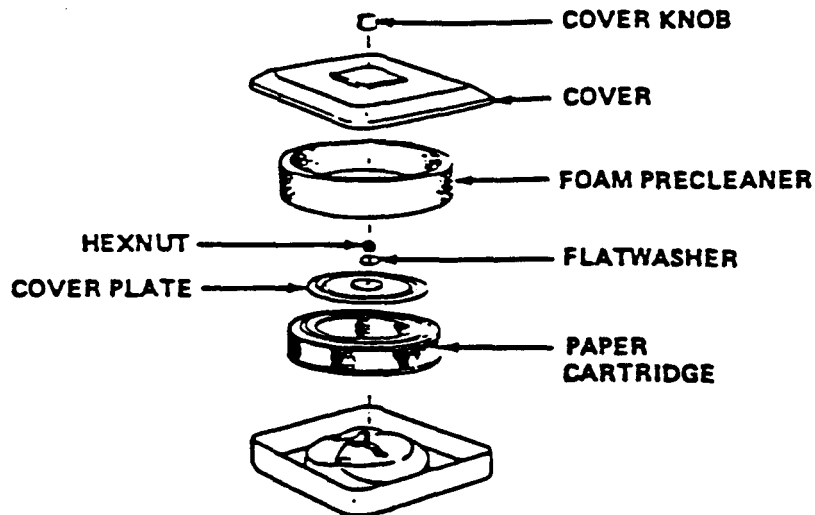
**REMOVAL**

1. Remove cover knob. Lift off cover.
2. Remove foam precleaned from around paper cartridge.
3. Remove hexnut and flatwasher.
4. Lift off cover plate. Remove paper cartridge.

INSTALLATION

1. Install new paper cartridge. Install cover plate.
2. Install hexnut and flatwasher. Hand-tighten.
3. Oil new foam precleaned with 1 oz (30 ml) of engine oil. Squeeze to spread oil.
4. Install foam precleaned around paper cartridge.
5. Install cover and cover knob.

4-27. CARBURETOR AND INTAKE MANIFOLD REPLACEMENT.

DESCRIPTION

This task covers: Removal and Installation

INITIAL SETUP

Equipment
Condition

<u>Para</u>	<u>Condition Description</u>	<u>Tools</u>
2-8	Engine stopped.	Tool Kit, General Mechanic's, item 1, Appendix B
4-15	Housing removed.	
4-20	Air cleaner elements removed.	<u>Materials/Parts:</u>
		Gasket (08645) 271412
		Gasket (08645) 270884
		Gasket (08645) 271411

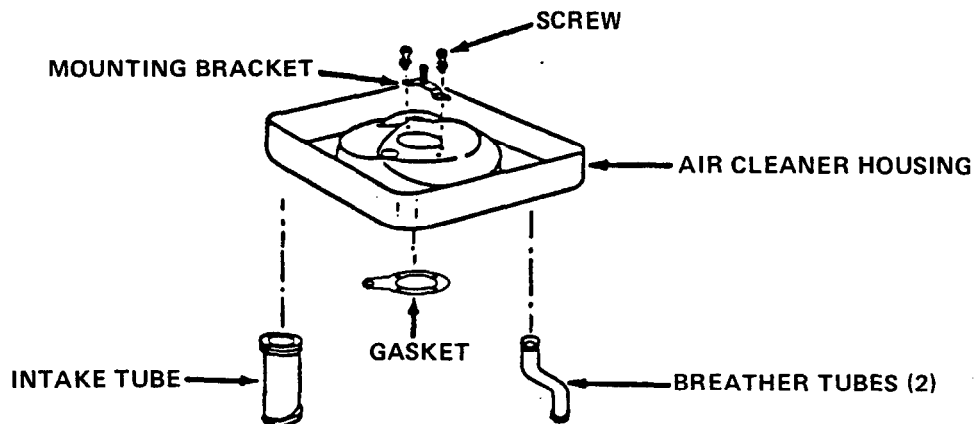

WARNING

Fuel may be present in carburetor. To prevent explosion or fire, keep sparks and open flame away from carburetor.

NOTE

Carburetor and intake manifold must be removed as an assembly before carburetor can be removed from intake manifold.

REMOVAL

1. Remove two air cleaner mounting screws.

4-27. CARBURETOR AND INTAKE MANIFOLD REPLACEMENT (CONT)

2. Remove mounting bracket and screws.
3. Remove air cleaner housing, gasket, intake tube and two breather tubes as one assembly.

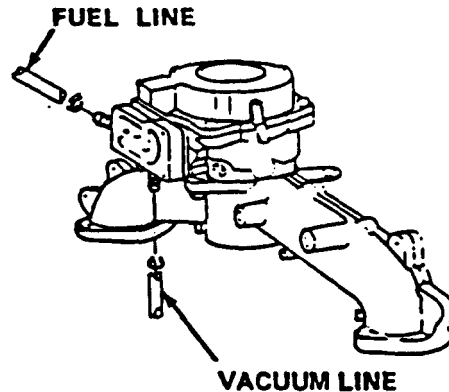

CAUTION

Do not pull lines at an angle or breakage of fuel pump body connectors may occur.

4. Disconnect fuel and vacuum lines.

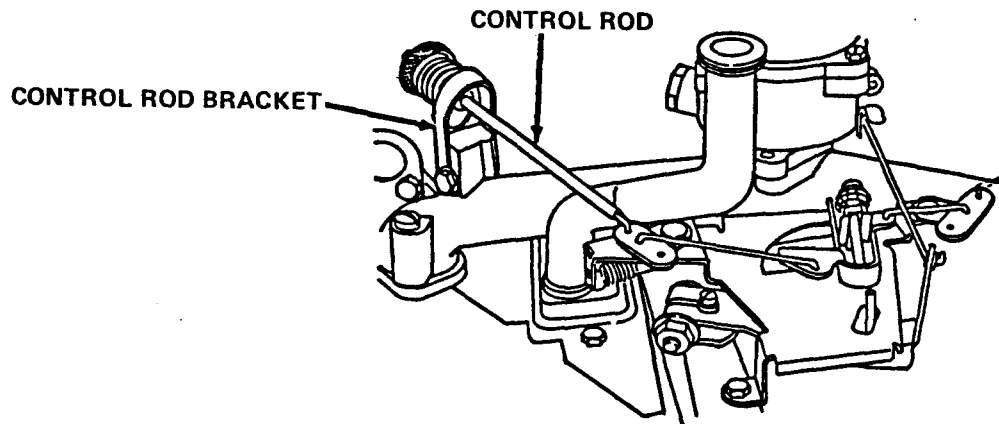

5. Unbolt control rod bracket. Remove control rod and control rod bracket.

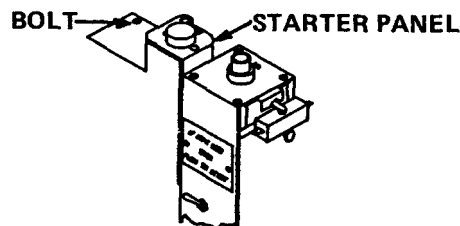

6. Remove one bolt attaching starter panel assembly to fan housing to allow removal of one screw in step 7.

4-27. CARBURETOR AND INTAKE MANIFOLD REPLACEMENT (CONT)

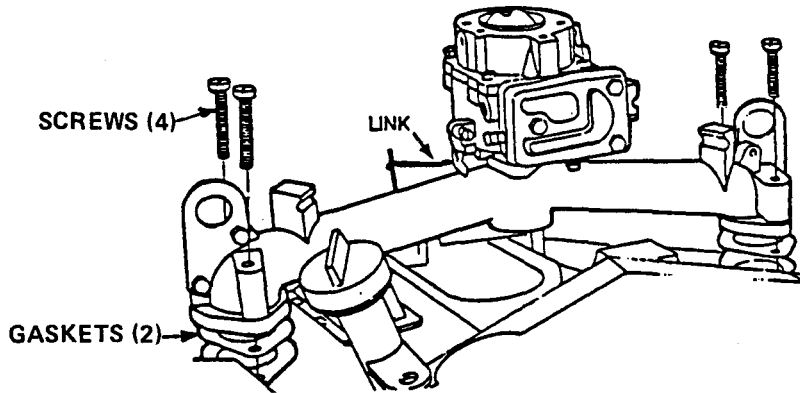

7. Remove four screws holding manifold to cylinder block assembly. Carefully lift carburetor and manifold assembly and disconnect linkage from governor arm while removing. Discard manifold gaskets.
8. Remove two carburetor mounting bolts and lockwashers from base of manifold.
9. Lift carburetor off manifold with vacuum hose.
10. Remove gasket and discard.

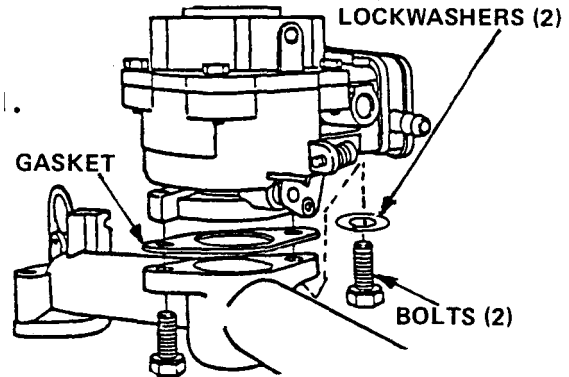

INSTALLATION

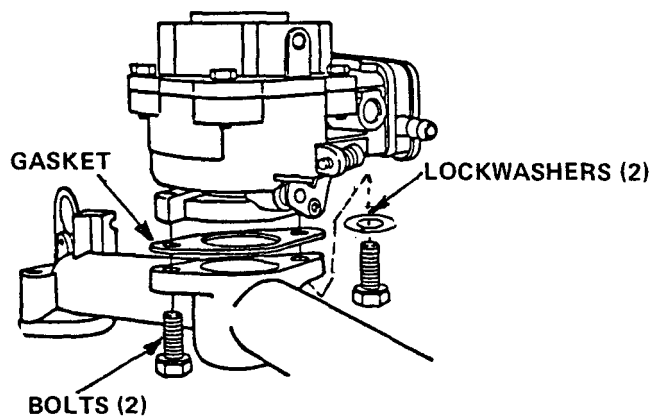

1. Install new gasket on manifold.
2. Install carburetor with two carburetor mounting bolts and lockwashers to manifold.

4-27. CARBURETOR AND INTAKE MANIFOLD REPLACEMENT (CONT)

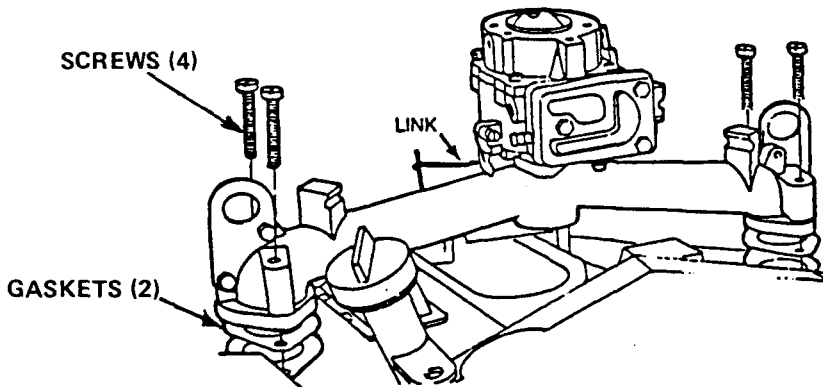

3. Place two new intake manifold gaskets on engine.
4. Hook governor link to governor arm while placing carburetor and manifold assembly on engine.
5. Install four screws holding manifold assembly to cylinder block.

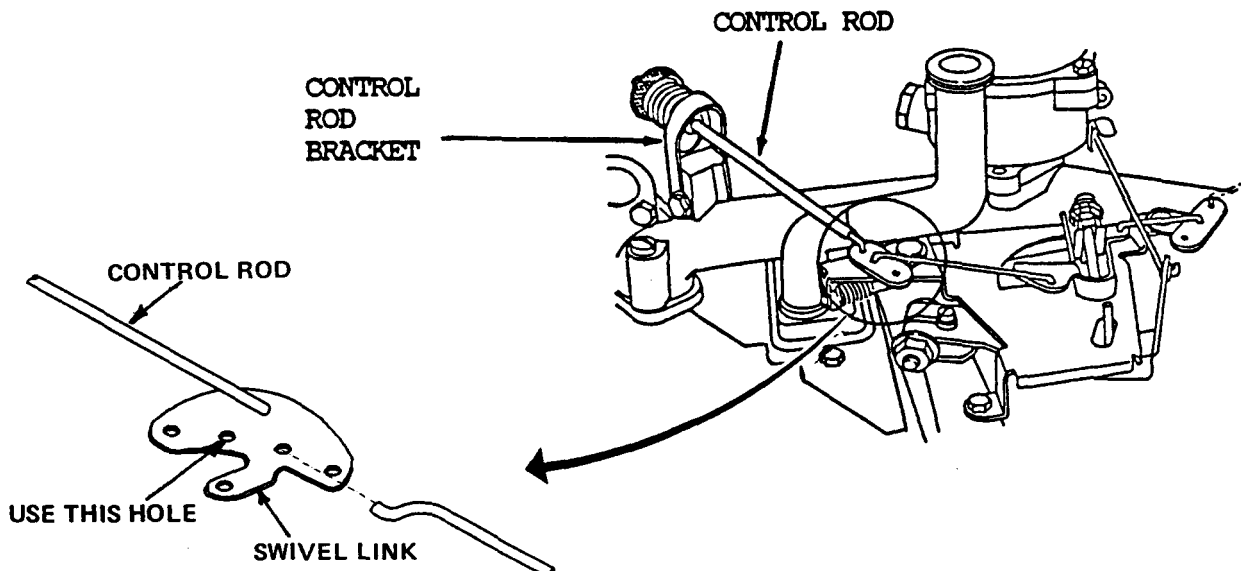

6. Hook control rod linkage and bolt control rod bracket to manifold.

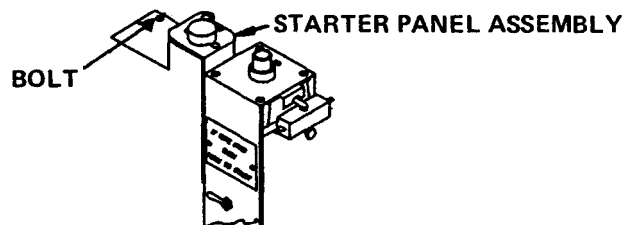

7. Install one bolt attaching switch bracket to fan housing.

4-27. CARBURETOR AND INTAKE MANIFOLD REPLACEMENT (CONT)

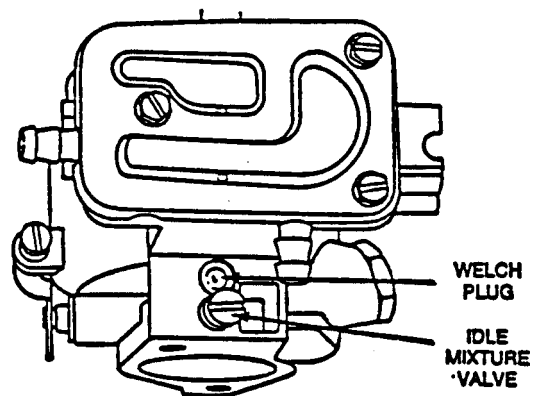

CAUTION

To prevent damage to valve (adjusting screw), DO NOT turn it too far or tight.

8. Turn idle mixture valve clockwise until it just seats. Turn counter-clockwise 1-1/2 turns. This setting will permit the engine to start.

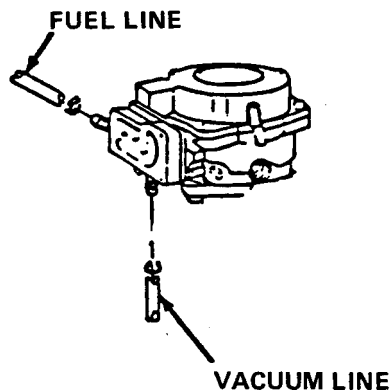

9. Connect fuel line and vacuum line.

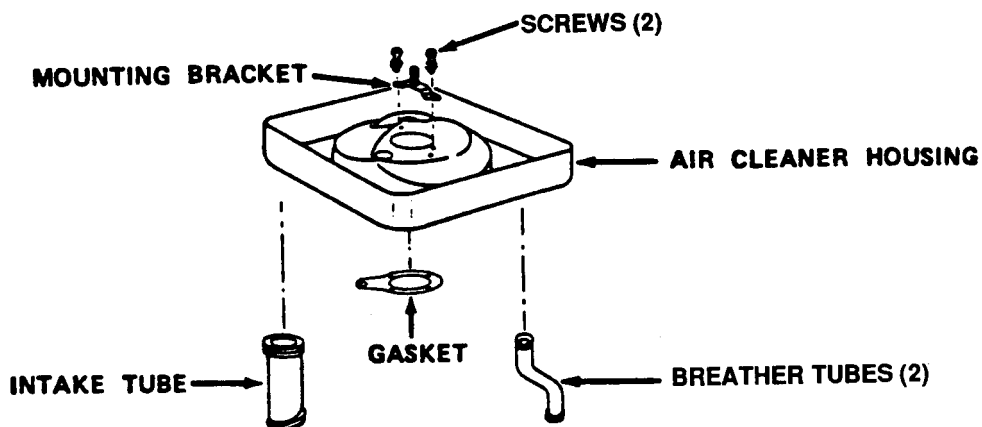

4-27. CARBURETOR AND INTAKE MANIFOLD REPLACEMENT (CONT)

CAUTION

Whenever the carburetor and manifold are removed, static governor adjustments should be checked (para 4-28c) . Failure to do so may result in engine overspeeding that may result in damage.

10. Install air cleaner housing, new gasket, intake tube and two breather tubes as one assembly.
11. Install mounting bracket and two screws.
12. Install air cleaner elements (para 4-26).

4-28. GOVERNOR CONTROL.

DESCRIPTION

This task covers: Removal, Installation, and Adjustment

INITIAL SETUP

Equipment
Condition

<u>Para</u>	<u>Condition Description</u>	<u>Tools</u>
2-8	Engine stopped.	Tool Kit, General
4-15	Housing removed.	Mechanic's, item 1, Appendix B
4-26	Air cleaner elements removed.	Wrench, torque (5120-00-640-6364), item 2, Appendix B
		Tachometer, Mechanical, Hand Held, item 1.3, Appendix B

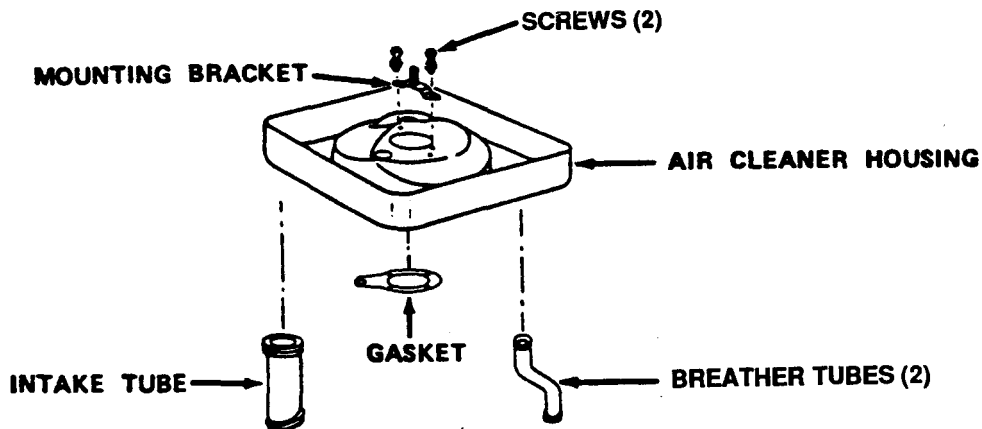

4-28. GOVERNOR CONTROL (CONT)

REMOVAL

1. Remove two air cleaner mounting screws.
2. Remove mounting bracket and screws. Remove air cleaner housing, gasket, intake tube, and two breather tubes as one assembly.

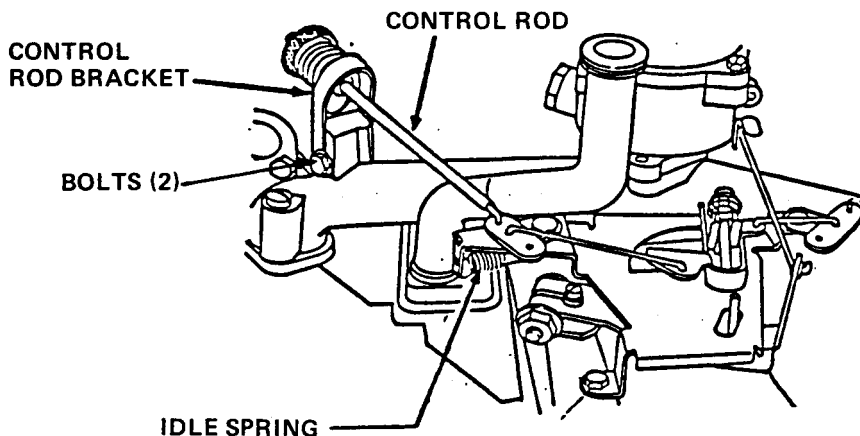

3. Unbolt control rod bracket. Remove control rod and control rod bracket assembly.
4. Unhook idle spring.

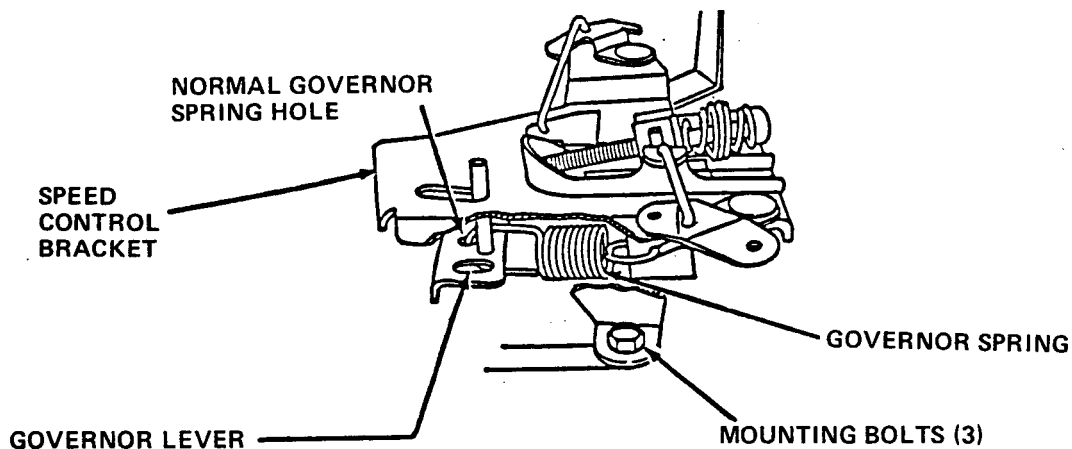

VIEWED FROM THROTTLE SIDE

5. Remove three mounting bolts from speed control bracket.
6. Lift up speed control bracket and unhook governor link spring.
7. Remove governor spring.
8. Remove idle spring.

4-28. GOVERNOR CONTROL (CONT)

9. Remove speed control bracket.

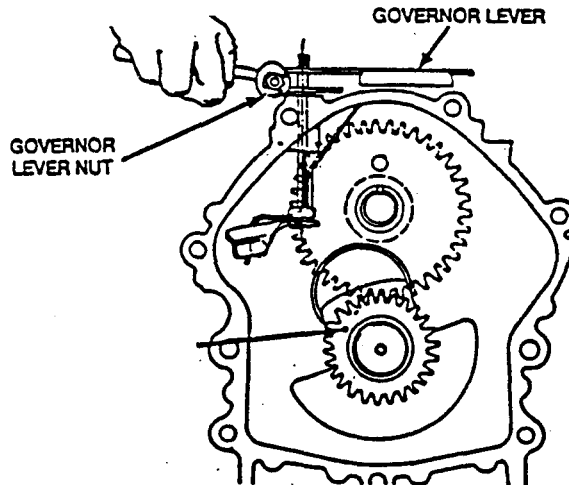

10. Loosen nut on governor lever, lift lever off governor shaft, then unhook throttle link.

INSTALLATION

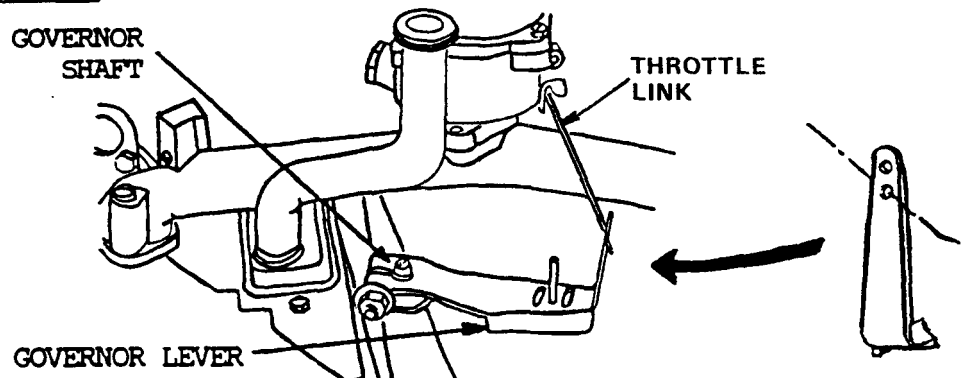

1. Hook throttle link in governor lever, use lower hole.
2. Slip governor lever with throttle link over governor shaft and tighten governor lever nut.

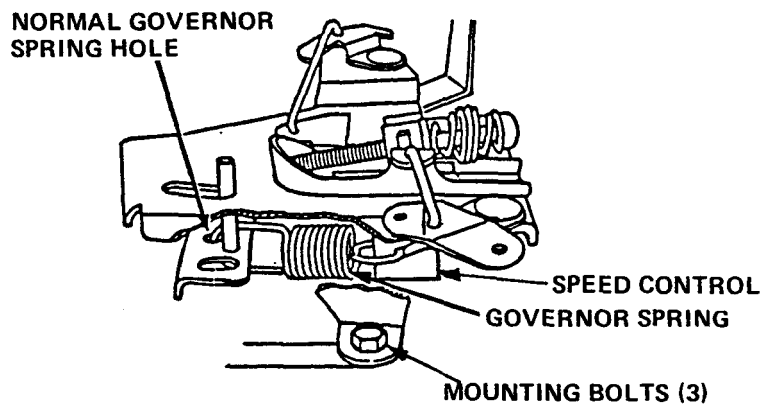

4-28. GOVERNOR CONTROL (CONT)

3. Hook governor spring in governor lever (hook in second hole from end of governor lever) .
4. Hook other end of governor spring in notch of speed control.
5. Mount speed control bracket on engine with three bolts.

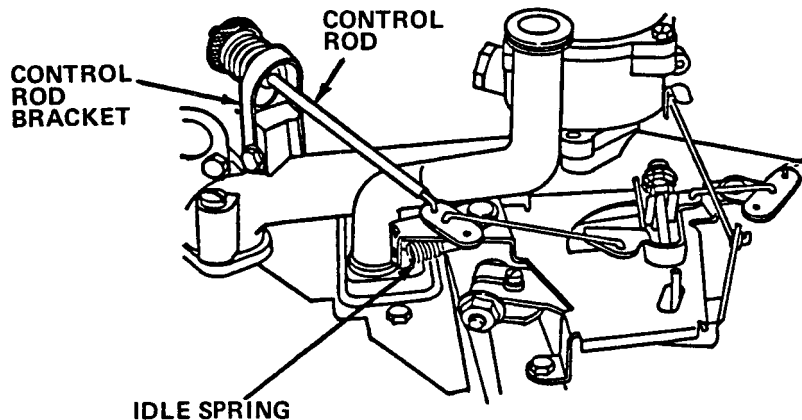

6. Install idle spring on speed control bracket.
7. Install control rod and control rod bracket assembly.
8. Follow instructions for the governor control adjustment procedures.

ADJUSTMENT

WARNING

Before starting or running engine, static adjustment of the governor must be made. Failure to make static adjustments first could result in engine overspeeding which may result in engine or equipment damage causing personal injury.

NOTE

All linkage must be installed prior to making any adjustments.

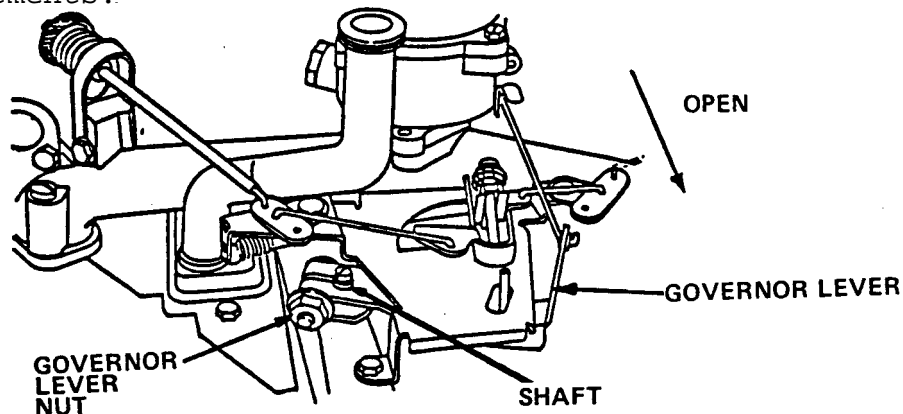

4-28. GOVERNOR CONTROL (CONT)

1. Loosen governor lever nut.
2. Push on governor lever until throttle is wide open.
3. Hold lever in this position and rotate governor shaft counter-clockwise as far as it will go.
4. Hold shaft in position and tighten governor lever nut.

CAUTION

Water Chiller must be connected to water supply for this adjustment.

5. Start engine (para 2-8b) and allow to run for five minutes.
6. Attach engine tachometer.

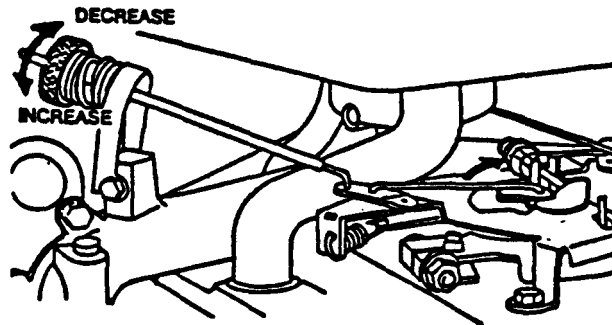

7. Adjust control rod nut to obtain 2700 RPM.

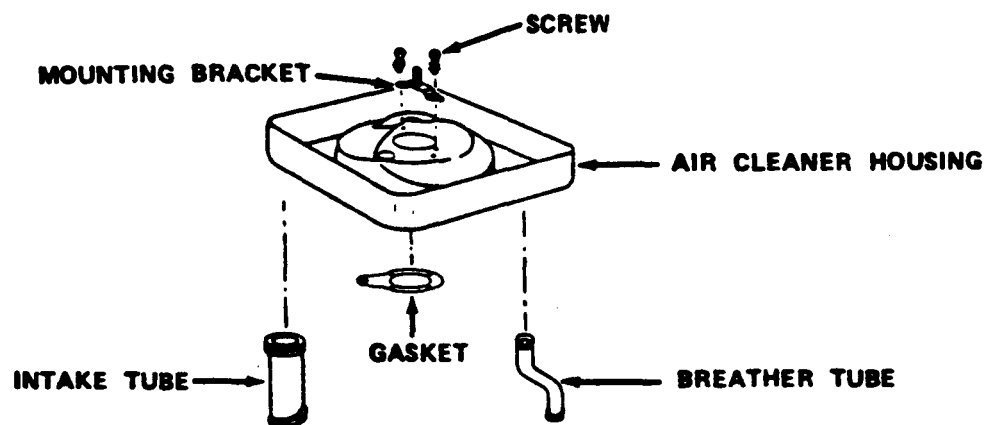

8. Install air cleaner housing, gasket, intake tube and two breather tubes.

4-28. GOVERNOR CONTROL (CONT)

- 9. Install mounting bracket and screws.
- 10. Install air cleaner elements (para 4-26).

4-29. STARTER PANEL ASSEMBLY REPLACEMENT.

DESCRIPTION

This task covers: Testing, Removal, and Installation

INITIAL SETUP

Equipment
Condition

<u>Para</u>	<u>Condition Description</u>	<u>Tools</u>
2-8	Engine Stopped.	Tool kit, General Mechanic's, item 1, Appendix B
4-15	Housing removed.	Multimeter, item 2, Appendix B

Materials/Parts:

- Tags, item 32, Appendix E
- Lockwasher MS353389-44

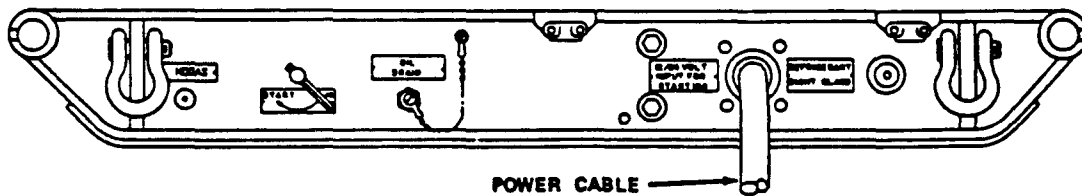

TESTING

1. Connect power cable to 12 VOLT INPUT FOR STARTING connection.
2. Set multimeter for voltage test.

4-29. STARTER PANEL ASSEMBLY REPLACEMENT (CONT)

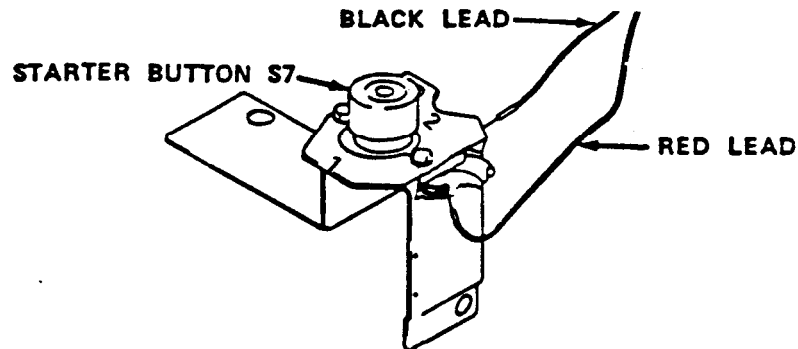

3. Place black lead on good ground (metal engine part). Place red lead on terminal (1) of starter button S7 leading to STARTER connection assembly. Note voltage. If voltage not present, replace cable.
4. Place red lead on terminal (2) of starter button S7 leading to starter.
5. Press starter button S7 and note voltage.
6. If voltage from second reading is the same as the first, switch is good. If voltage from second reading is less than first, replace switch.

4-29. STARTER PANEL ASSEMBLY REPLACEMENT (CONT)

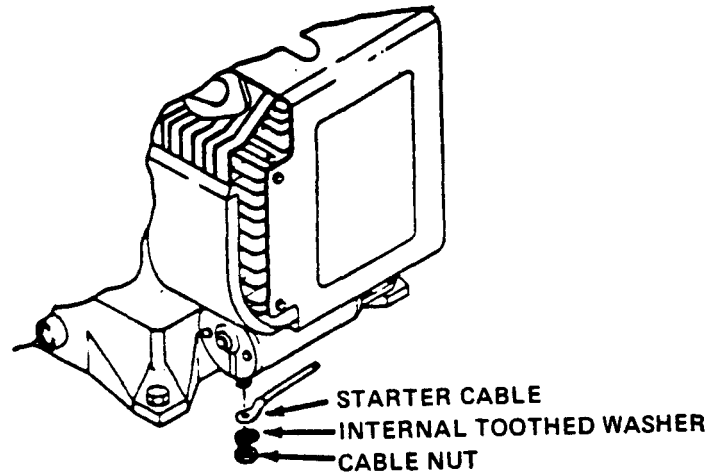

WARNING

To prevent electric shock, make sure power is disconnected from 12 VOLT INPUT FOR STARTING connection before performing this procedure.

- Place red lead on starter terminal. Press starter button S7. If voltage is present, cable is good. If voltage is less than voltage at starter button, replace cable.

REMOVAL

- Disconnect power cable from 12 VOLT INPUT FOR STARTING connection.

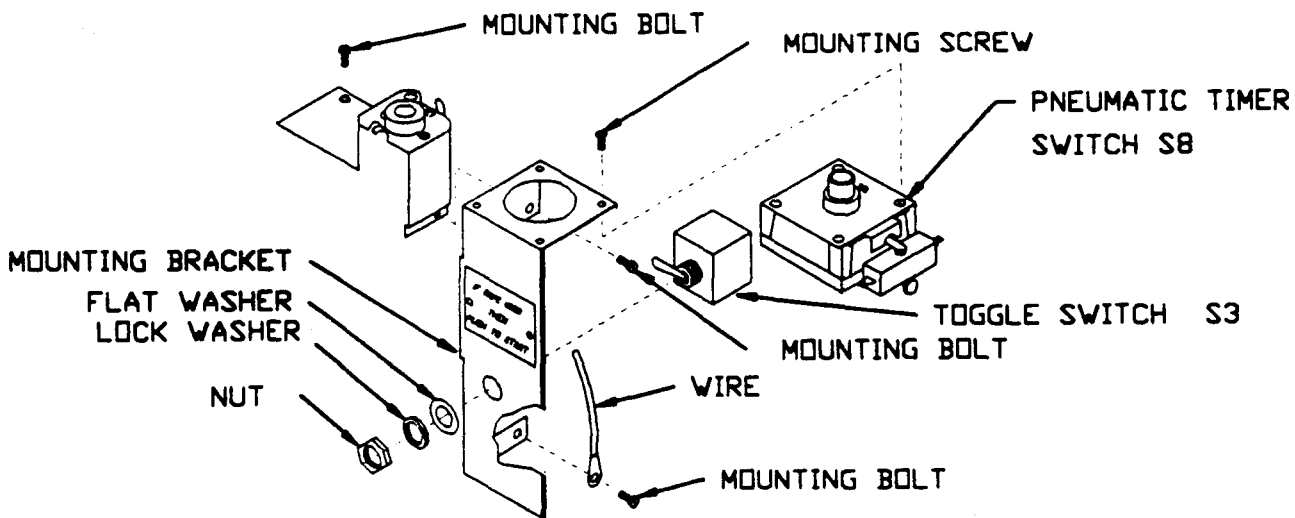

- Remove mounting nut, lockwasher, and flatwasher. Remove toggle switch S3 from mounting bracket.

4-29. STARTER PANEL ASSEMBLY REPLACEMENT (CONT)

3. Remove mounting screws from pneumatic timer switch. Remove timer switch from mounting bracket.
4. Remove three mounting bracket bolts. Remove mounting bracket.

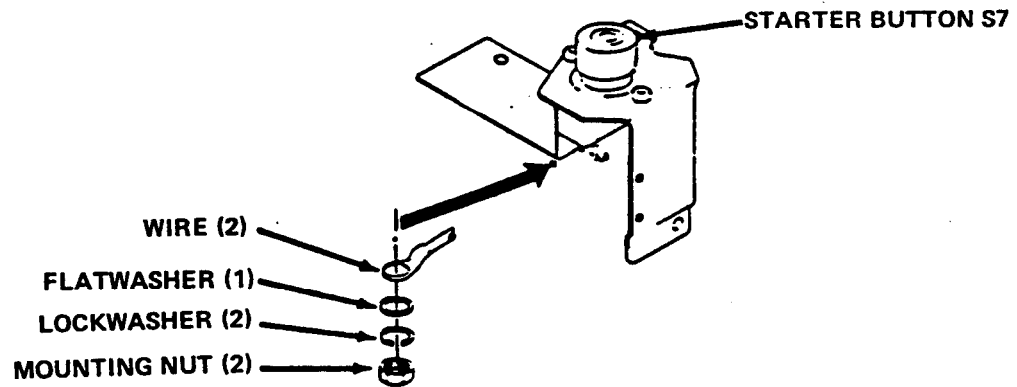

5. Tag two wires under starter button S7.
6. Remove two wire mounting nuts, lockwashers, and one flatwasher. Remove two wires.

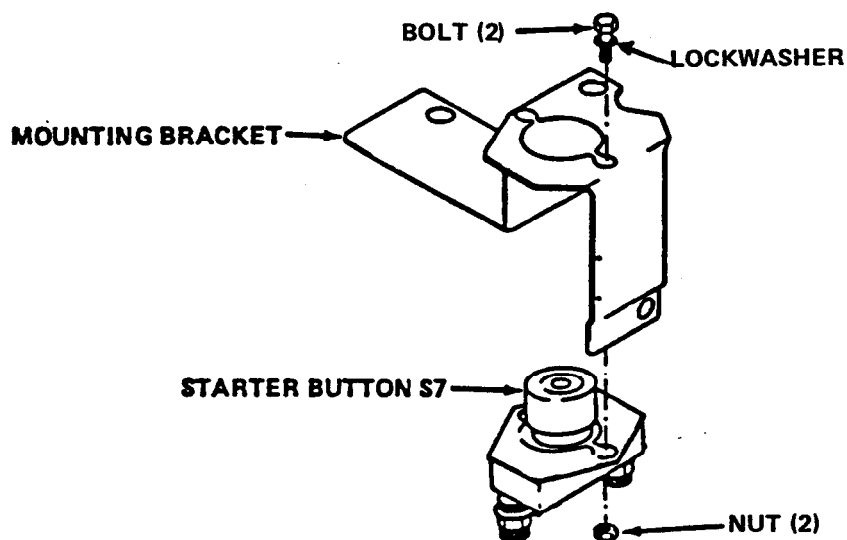

7. Remove two mounting bolts with lockwasher, flatwasher, and two nuts.
8. Remove starter button S7.
9. Remove cable nut and internal toothed washer from starter. Remove starter cable.

4-29. STARTER PANEL ASSEMBLY REPLACEMENT (CONT)

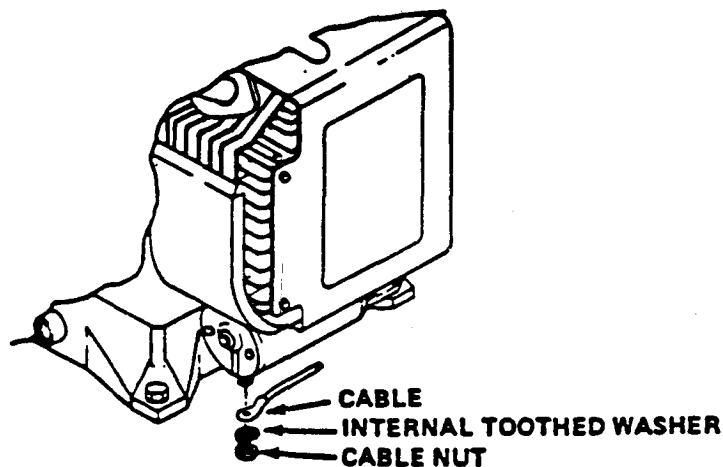

WARNING

To prevent electric shock, make sure power is disconnected from 12 VOLT INPUT FOR STARTING connection before performing this procedure.

10. Remove starter cable mounting clamp bolt from blower housing.
Remove starter cable mounting clamp from starter cable.
11. Remove starter cable mounting nut, and flatwasher, from switch S7.
Remove starter cable

INSTALLATION

1. Install starter cable on switch S7. Install flatwasher, lockwasher, and starter cable mounting nut.
2. Install starter cable mounting clamp on starter cable. Install starter cable mounting clamp and bolt on blower housing.
3. Install starter cable on starter. Install internal toothed washer and cable nut on starter.

4-29. STARTER PANEL ASSEMBLY REPLACEMENT (CONT)

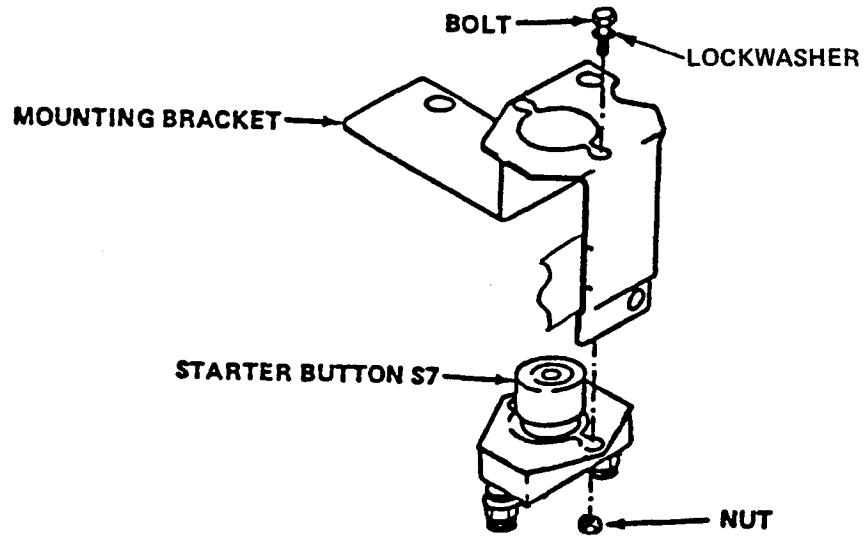

4. Install starter button S7 in mounting bracket. Install two bolts, lockwashers, flatwashers, and nuts.
5. Install two wires. On terminal stud number 1 place one washer. Place a lockwasher and nut on each terminal and tighten. Remove tags.
6. Install mounting bracket on engine. Install toggle switch ground S3 wire on mounting bolt. Install three mounting bolts.

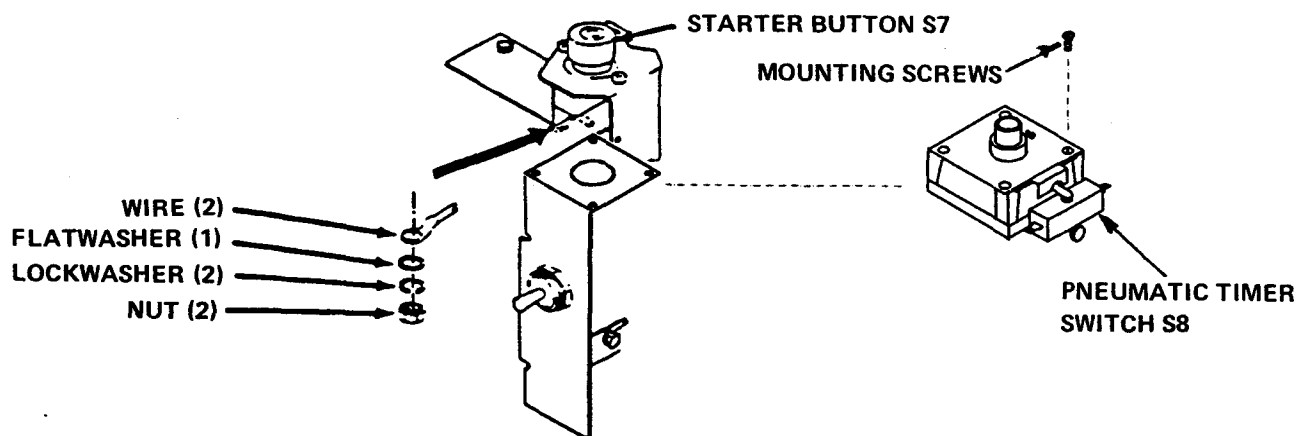

4-29. STARTER PANEL ASSEMBLY REPLACEMENT (CONT)

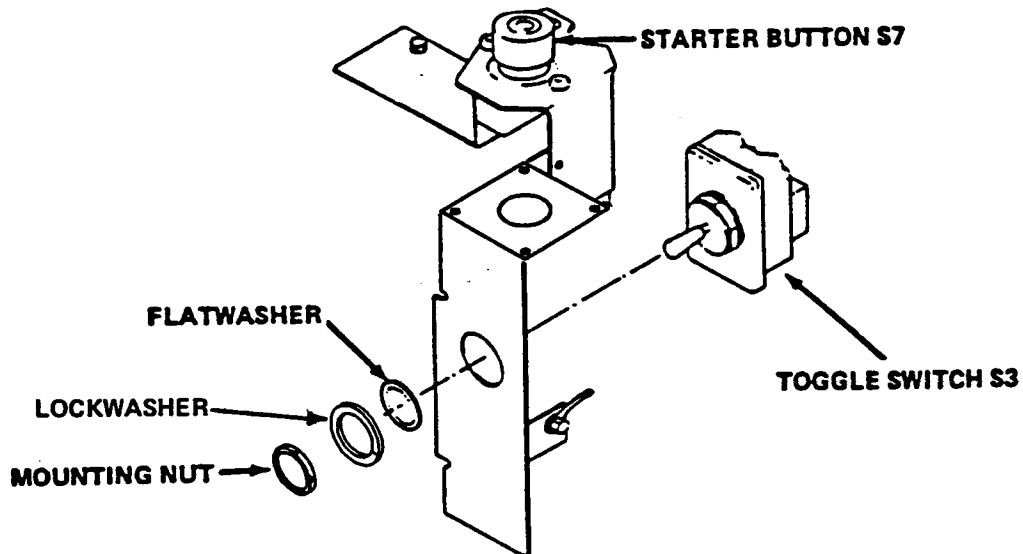

7. Install toggle switch S3 in mounting bracket. Install flatwasher, lockwasher, and mounting nut.
8. Install pneumatic timer switch. Attach with mounting screws.

4-30. SPARK PLUGS REPLACEMENT.

DESCRIPTION

This task covers: Test, Removal, Adjustment, and Installation

INITIAL SETUP

Equipment
Condition

<u>Para</u>	<u>Condition Description</u>	<u>Tools</u>
2-8	Engine stopped.	Tool Kit, General Mechanic's, item 1, Appendix B
4-15	Housing removed.	

Personnel Required:

Two for testing

4-30. SPARK PLUGS REPLACEMENT (CONT)

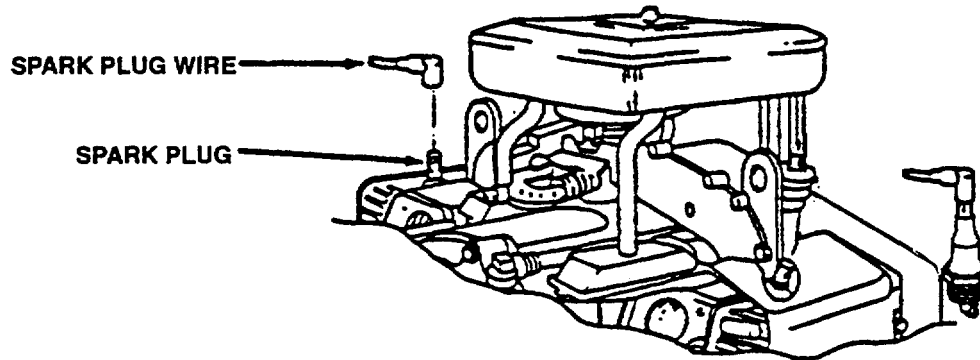
TEST

1. Remove spark plug from one cylinder. Reconnect spark plug wire.
2. Remove second spark plug wire to prevent engine from starting.
3. Ground spark plug. While cranking engine check for spark.
Repeat steps 1 through 3 on the other cylinder.
4. Readjust engine speed to 1200 RPM.

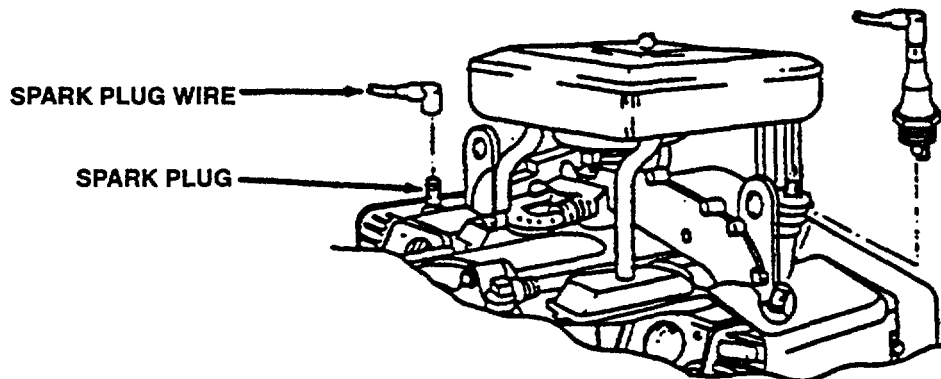
**REMOVAL**

1. Remove two spark plug wires from spark plugs.
2. Remove two spark plugs.

ADJUSTMENT

Gap each spark plug to 0.30 in. (0.76 mm).

INSTALLATION

1. Install two spark plugs and tighten
2. Attach two spark plug wires to spark plugs.

4-31. ARMATURE GROUP REPLACEMENT.

DESCRIPTION

This task covers: Inspection, Testing, Adjustment, Removal, and Installation

INITIAL SETUP

Equipment
Condition

<u>Para</u>	<u>Condition Description</u>	<u>Tools</u>
2-8	Engine stopped.	Tool Kit, General Mechanic's, item 1, Appendix B
4-15	Housing removed.	

Materials/Parts:

Sealant, item 3, Appendix E
Solder, item 30, Appendix E
Tape, item 33, Appendix E
Lockwasher MS35338-140
Lockwasher MS35338-44

Personnel Required:

Two for testing

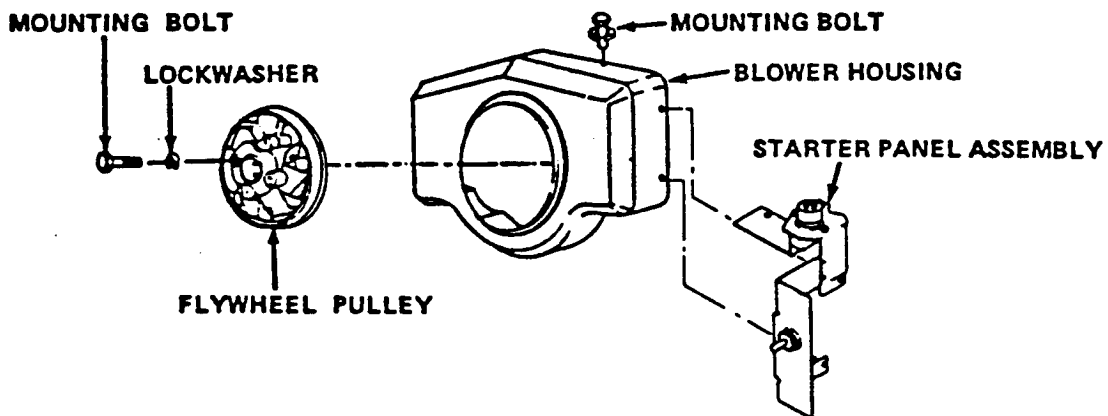

INSPECTION

1. Remove two flywheel pulley mounting bolts and two lockwashers. Remove flywheel pulley.
2. Remove eight blower housing mounting bolts. Remove blower housing.
3. Move starter panel assembly aside.

4-31. ARMATURE GROUP REPLACEMENT (CONT)

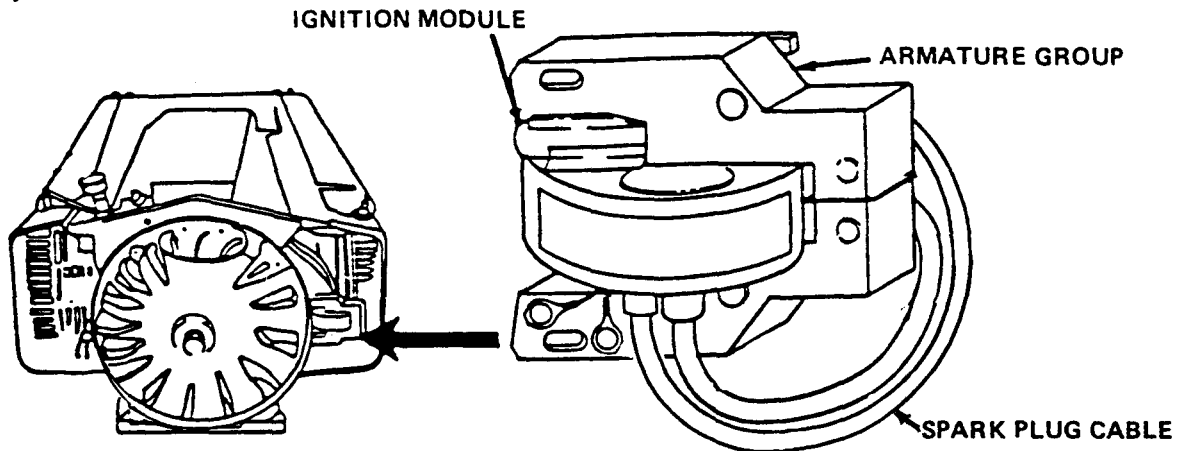

4. Check armature group for dirt, oil, and rust. Clean as needed.
5. Check for loose spark plug wire connections on ignition module. If spark plug cable connection loose, replace armature group.
6. Check condition of spark plug cables. If cables damaged, replace armature group.

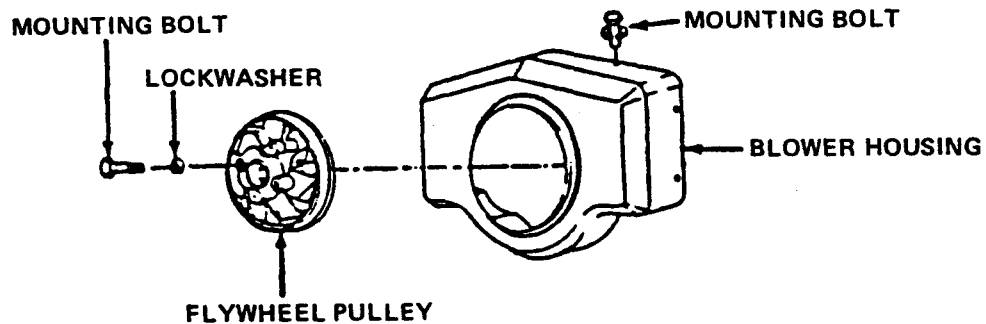

7. Install blower housing. Install eight blower housing mounting bolts and starter cable clamp.
8. Install flywheel pulley. Install flywheel pulley mounting bolts.

4-31. ARMATURE GROUP REPLACEMENT (CONT)

TESTING

WARNINGS

Be sure there is no fuel or fuel vapor present, which might be ignited by the spark and cause a fire or explosion.

To prevent electric shock, be careful when connecting power cable to 12/24 VOLT INPUT FOR STARTING connection.

NOTES

Ignition system requires a minimum of 350 RPM to produce a spark.

Two persons may be required for next step.

1. Remove spark plug wires.

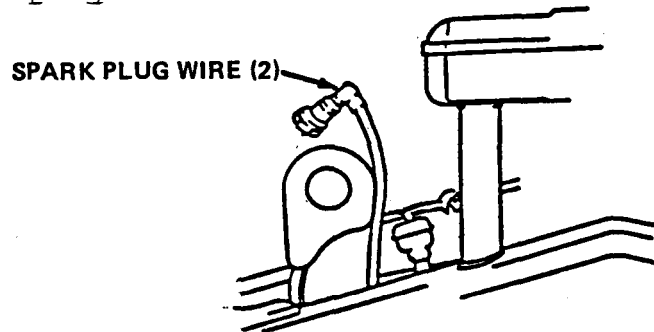

2. Hold spark plug wire approx. 1/8 in. (1/3 cm) from ground (any metal section of engine).

NOTE

Two persons may be required for next step.

3. If electrical power available: Insert power cable in 12/24 VOLT INPUT FOR STARTING connection. Hold toggle switch S3 in START position and press down starter button S7.
4. If electrical power unavailable: Press pneumatic timer switch S8 and pull starter rope.
5. If spark jumps the 1/8 in. (1/3 cm) gap, you may assume the ignition system is functioning satisfactory.

4-31. STARTER PANEL ASSEMBLY REPLACEMENT (CONT)

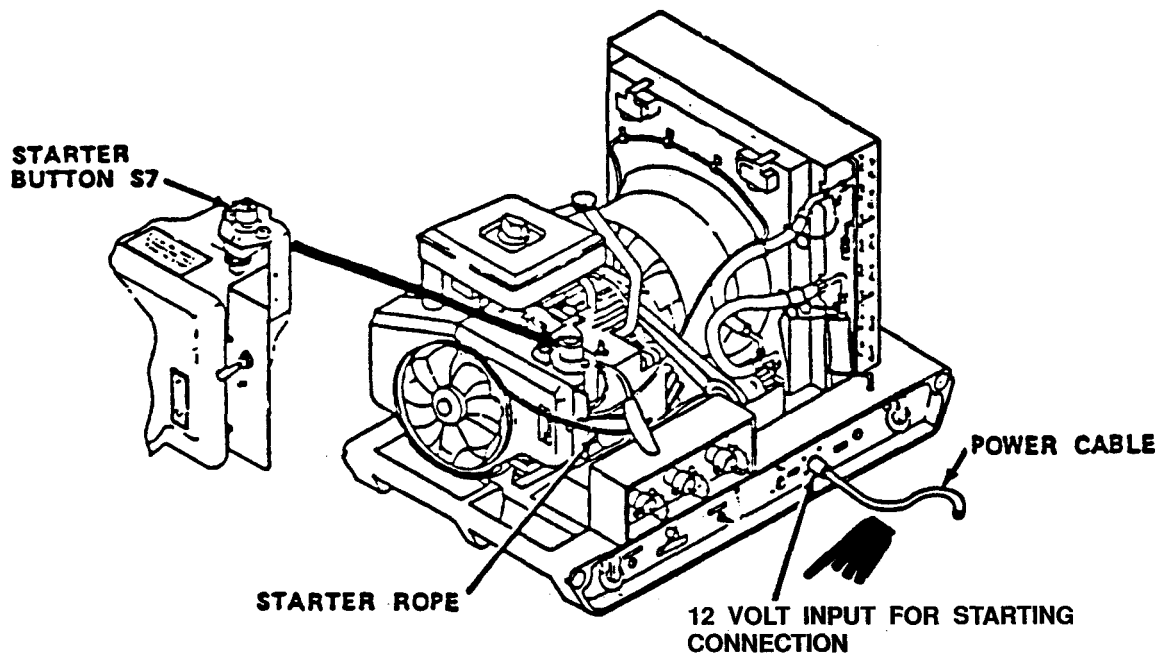

6. If spark fails to jump the gap to ground, replace armature group.
7. Repeat steps 1. through 6. for other cylinder.
8. Install spark plug wires.

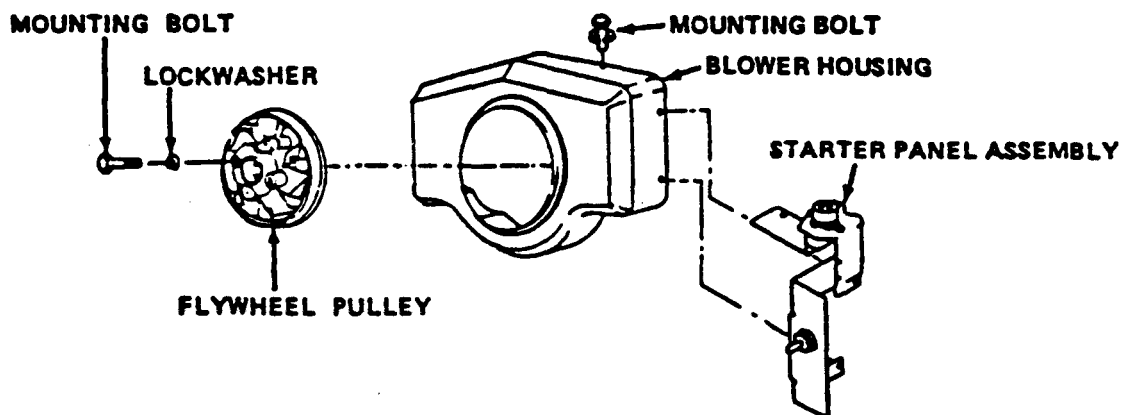

ADJUSTMENT

1. Remove two flywheel pulley mounting bolts and two lockwashers. Remove flywheel pulley.
2. Remove eight blower housing mounting bolts. Remove blower housing.

4-31. ARMATURE GROUP REPLACEMENT (CONT)

3. Move starter panel assembly aside.

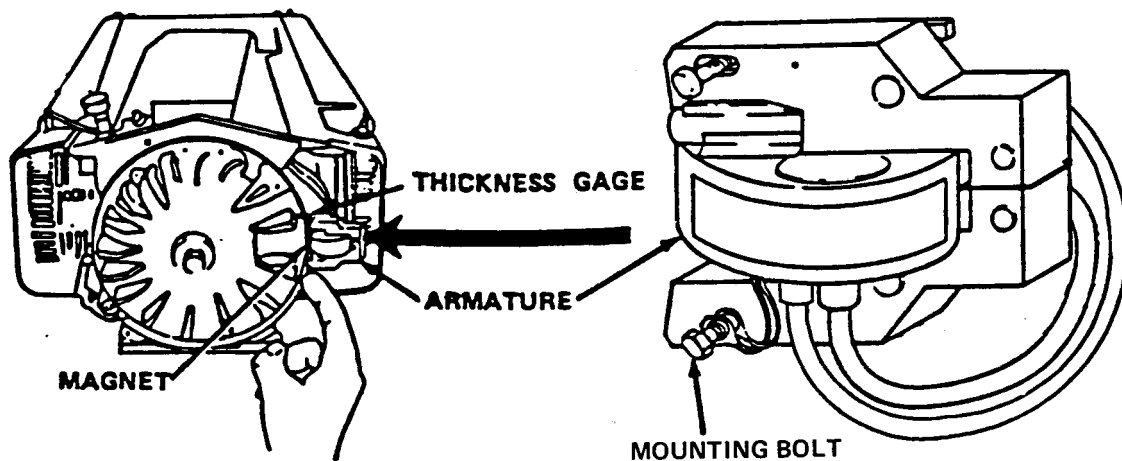

4. Insert 0.010 in. (0.254 mm) thickness gauge between armature and flywheel with magnet directly in front of armature.

5. Loosen two armature mounting bolts. Allow magnet to pull armature down firmly against thickness gauge.

6. Tighten two armature mounting bolts.

7. Remove thickness gauge.

8. Install blower housing. Install eight blower housing mounting bolts and starter clamp.

9. Install flywheel pulley. Install two flywheel pulley mounting bolts and two lockwashers.

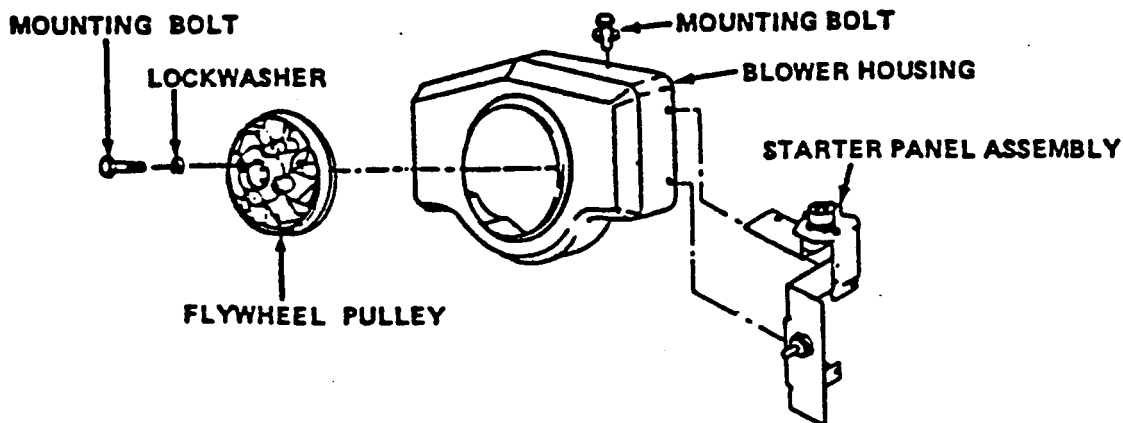

4-31. ARMATURE GROUP REPLACEMENT (CONT)

REMOVAL

1. Remove carburetor and intake manifold (para 4-27).
2. Remove two flywheel pulley mounting bolts and two lockwashers. Remove flywheel pulley.
3. Remove eight blower housing mounting bolts. Remove blower housing. Move starter panel assembly aside.
4. Disconnect spark plug cables from spark plugs.

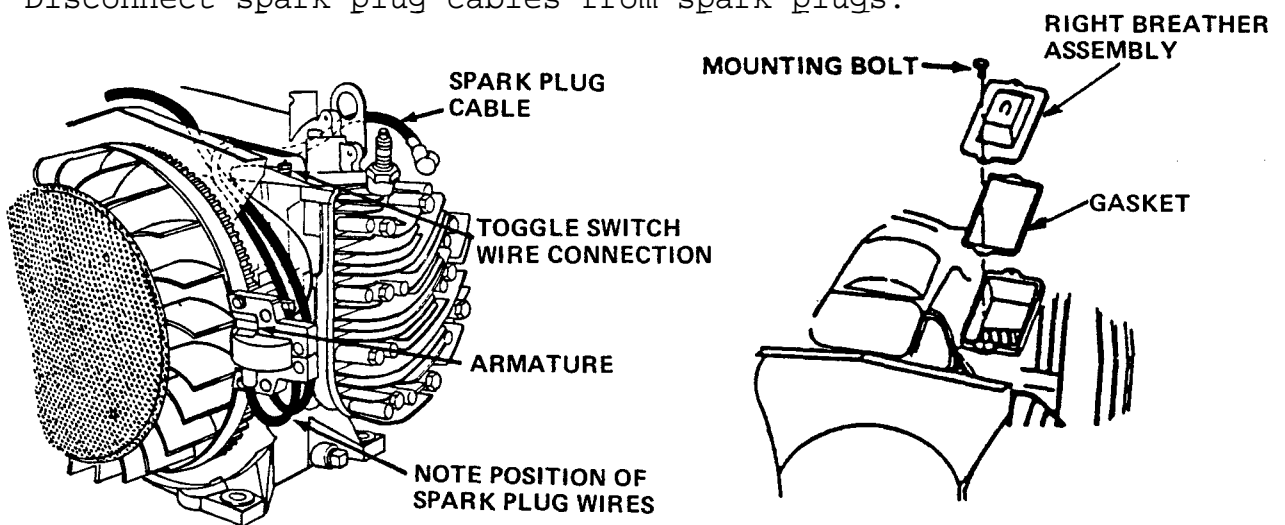

5. Remove right breather assembly mounting bolts and toggle switch wires from breather assembly. Remove breather assembly.

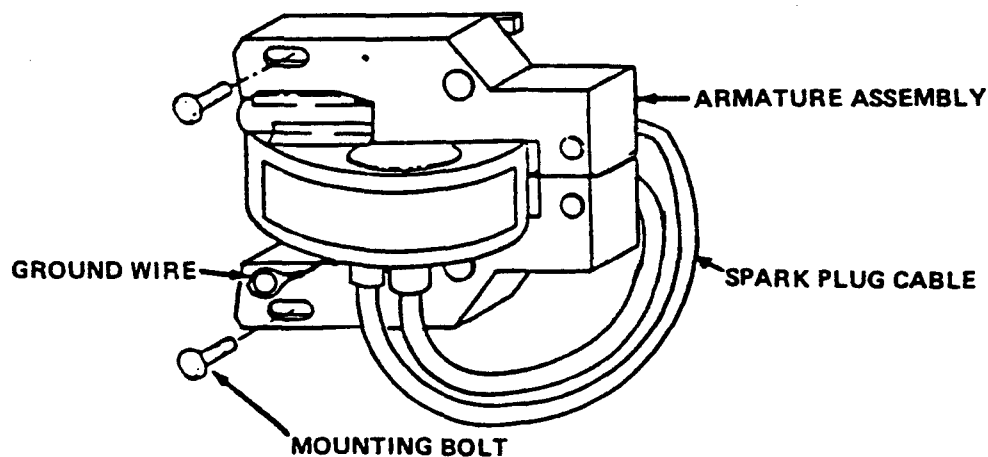

6. Remove two armature mounting bolts.

4-31. ARMATURE GROUP REPLACEMENT (CONT)

7. Remove armature assembly, stop wire and spark plug cables from engine.

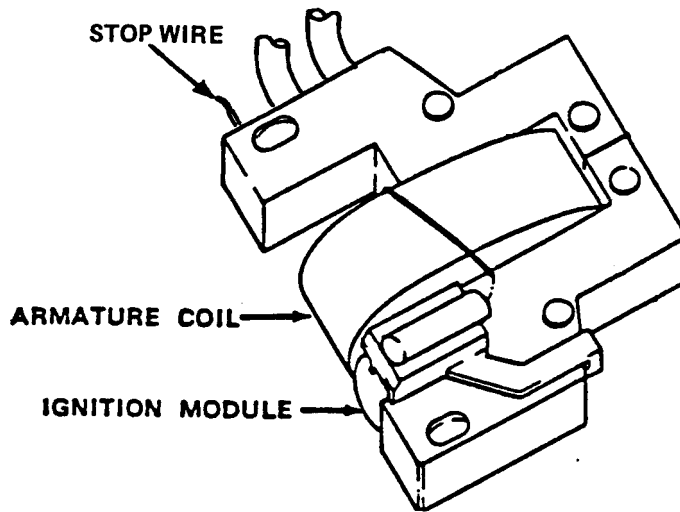

8. Remove stop wire.

INSTALLATION

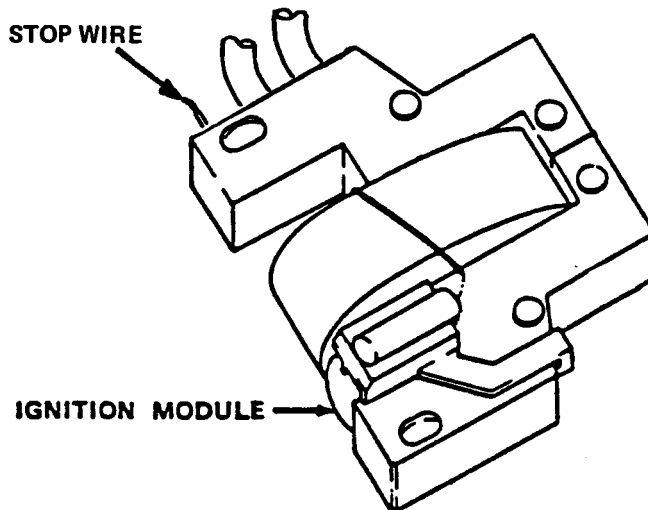

1. Install armature stop wire to ignition module.

4-31. ARMATURE GROUP REPLACEMENT (CONT)

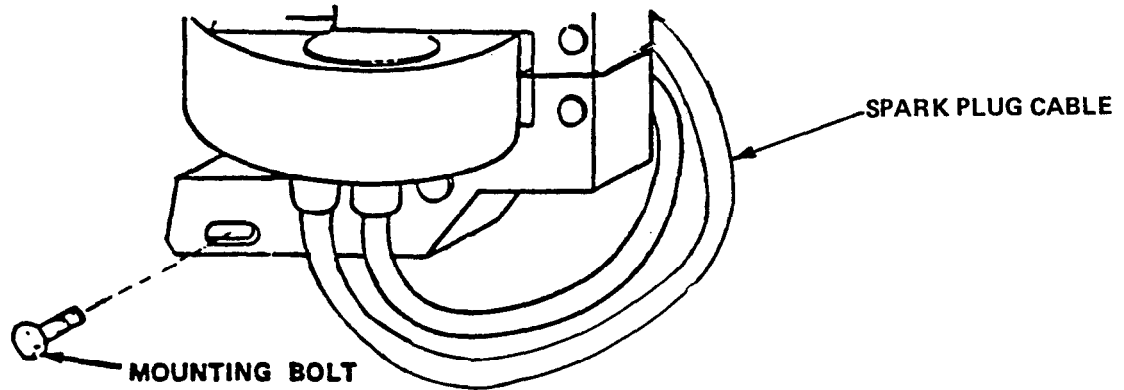

2. Install armature assembly, stop wire and spark plug cables on engine.
3. Install two armature mounting bolts.
4. Adjust armature assembly.
5. Install right breather assembly and stop switch wires.

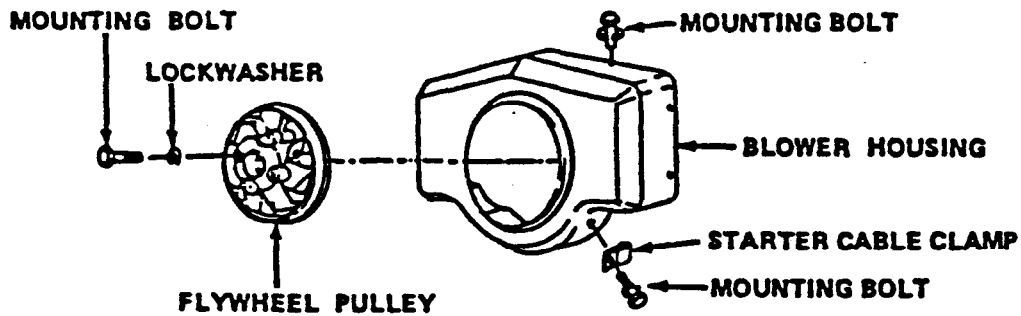

6. Install blower housing. Install eight blower housing mounting bolts and starter cable clamp.
7. Install flywheel pulley. Install two lockwashers and two flywheel pulley mounting bolts.
8. Install carburetor and intake manifold (para 4-27).
9. Install air cleaner housing, gasket, intake tube and breather tubes.
10. Install mounting bracket and screws.
11. Install air cleaner elements (para 4-26).

4-32. DIPSTICK AND TUBE ASSEMBLY REPLACEMENT.

DESCRIPTION

This task covers: Removal and Installation

INITIAL SETUP

Equipment
Condition

<u>Para</u>	<u>Condition Description</u>	<u>Tools</u>
2-8	Engine stopped.	Tool Kit, General Mechanic's, item 1, Appendix B
4-15	Housing removed.	

Materials/Parts:

- Lockwasher MS35338-140
- Lockwasher MS35338-44

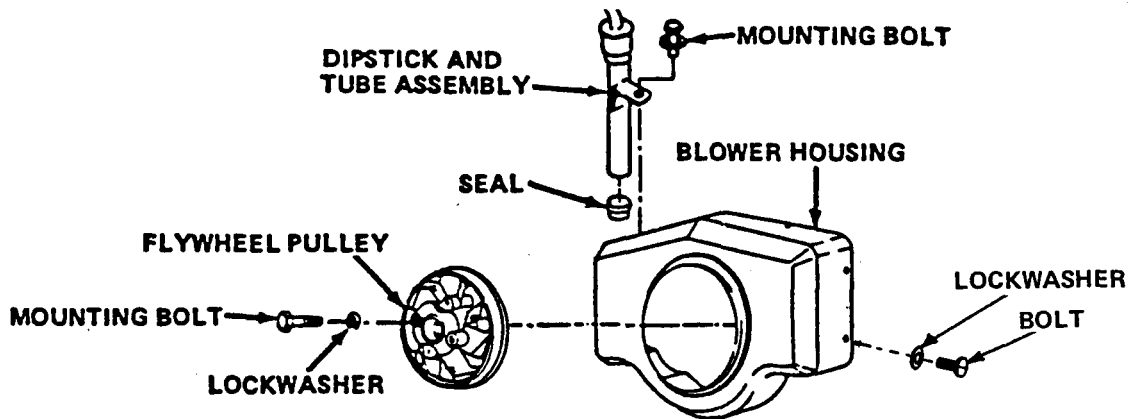

REMOVAL

1. Remove two flywheel pulley mounting bolts and two lockwashers. Remove flywheel pulley.
2. Remove eight blower housing mounting bolts. Remove blower housing and lay starter panel assembly to side.
3. Remove dipstick from tube. Remove tube.
4. Remove seal from engine.

4-32. DIPSTICK AND TUBE ASSEMBLY REPLACEMENT (CONT)

INSTALLATION

1. Install seal in engine.
2. Install tube.
3. Insert dipstick in tube.
4. Install blower housing and starter panel assembly. Install eight blower housing mounting bolts.
5. Install flywheel pulley. Install two lockwashers and flywheel pulley mounting bolts.

4-33. STARTER REPLACEMENT.

DESCRIPTION

This task covers: Removal and Installation

INITIAL SETUP

Equipment
Condition

<u>Para</u>	<u>Condition Description</u>	<u>Tools</u>
2-8	Engine stopped.	Tool Kit, General Mechanic's, item 1, Appendix B Multimeter, item 2, Appendix B
4-15	Housing removed.	
4-34	Flywheel removed.	

Materials/Parts:

Lockwasher MS35338-45

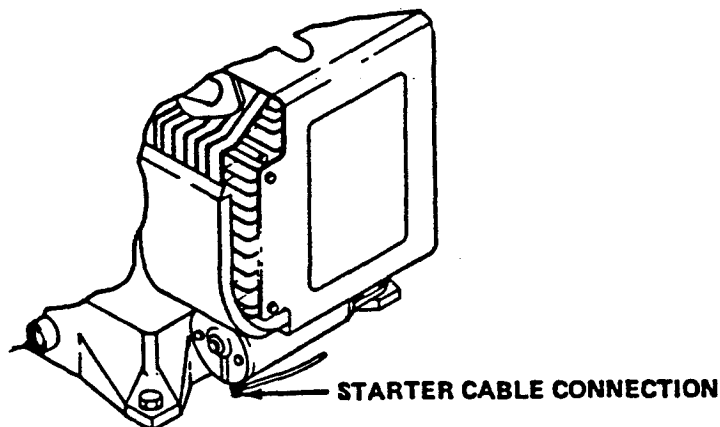

4-33. STARTER REPLACEMENT (CONT)

REMOVAL

WARNING

To prevent electric shock, make sure power is disconnected from 12/24 VOLT INPUT FOR STARTING connection before removing cable nut.

1. Remove cable nut and internal toothed washer from starter.
2. Remove cable from starter.

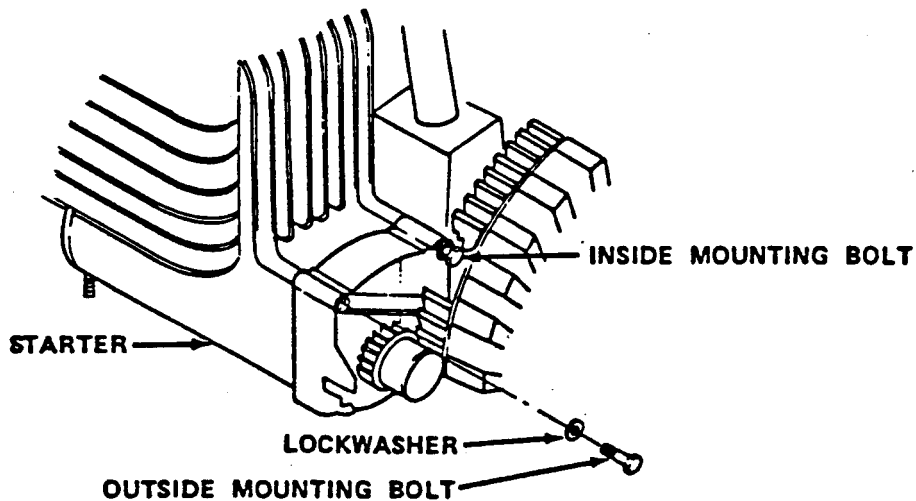

3. Remove inside mounting bolt.

CAUTION

To prevent damage to starter, place hand under starter to catch it as outside mounting bolt is removed.

4. Remove outside mounting bolt and lockwasher.
5. Remove starter.

INSTALLATION

1. Install starter with two bolts and lockwashers.

4-33. STARTER REPLACEMENT (CONT)

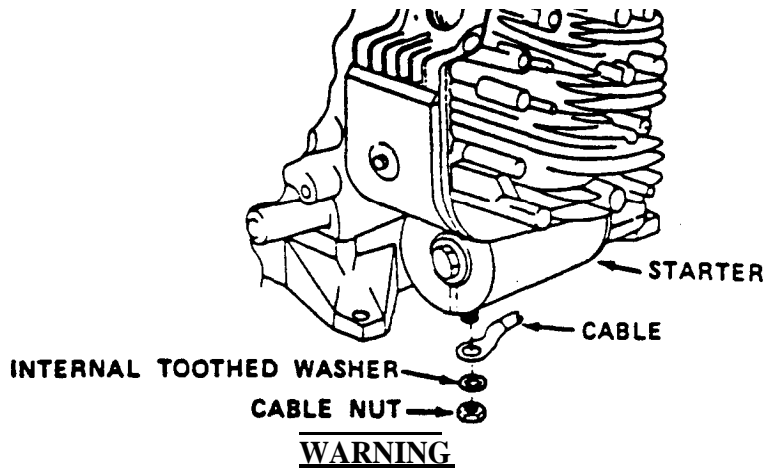

To prevent electric shock, make sure power is disconnected from 12 VOLT INPUT FOR STARTING connection before installing cable nut.

2. Install cable on starter with internal tooth washer and nut.
3. Install flywheel (para 4-34).

4-34. FLYWHEEL AND RING GEAR ASSEMBLY REPLACEMENT.

DESCRIPTION

This task covers: Removal, Disassembly, Assembly and Installation

INITIAL SETUP

Equipment Condition

<u>Para</u>	<u>Condition Description</u>	<u>Tools</u>
2 - 8	Engine Stopped.	Tool kit, General Mechanic's, item 1, Appendix B
4-15	Housing removed.	Puller Kit, Mechanical, item 2, Appendix B
<u>Materials/Parts:</u>		Wrench, torque, item 2, Appendix B
Lockwasher MS35338-140		Flywheel Holder, item 9, Appendix B
Lockwasher MS35338-44		

4-34. FLYWHEEL AND RING GEAR ASSEMBLY REPLACEMENT (CONT)

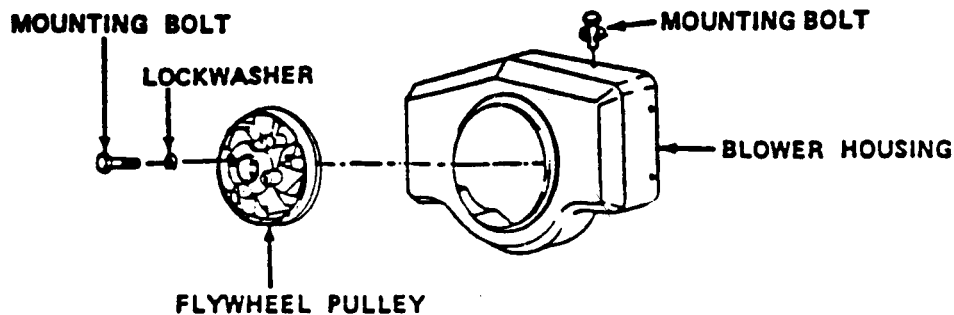

REMOVAL

1. Remove two flywheel pulley mounting bolts and two lockwashers. Remove flywheel pulley.
2. Remove eight mounting bolts from blower housing and starter panel assembly. Move starter panel assembly to side. Remove starter cable clamp. Remove blower housing.

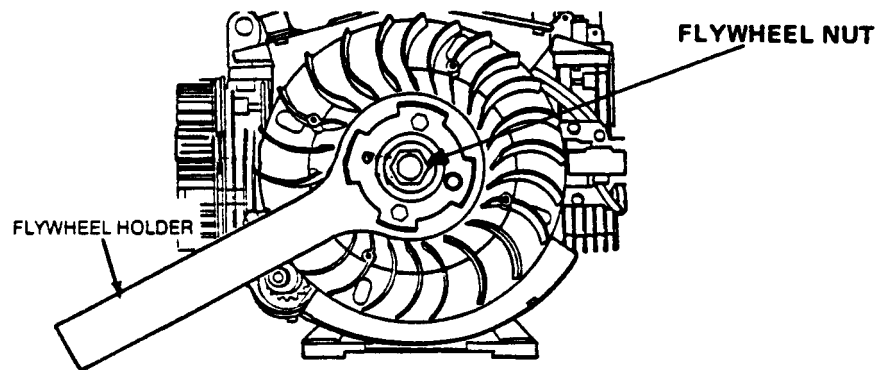

3. Use flywheel holder to prevent turning.
4. Remove flywheel nut and flatwasher.
5. Attach flywheel puller and remove flywheel assembly. Remove puller.
6. Remove key.

4-34. FLYWHEEL AND RING GEAR ASSEMBLY REPLACEMENT (CONT)

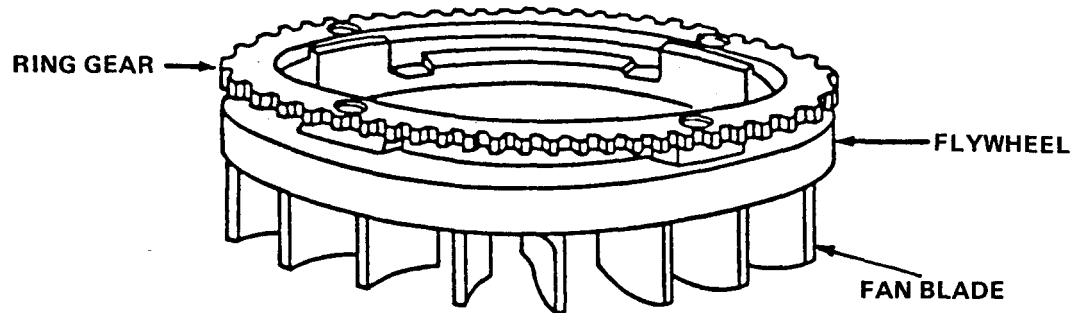

7. Inspect flywheel for worn keyway. Inspect ring gear for worn or missing teeth. Inspect fan for missing blades.

DISASSEMBLE

1. Place assembly on flat surface with fan side up.

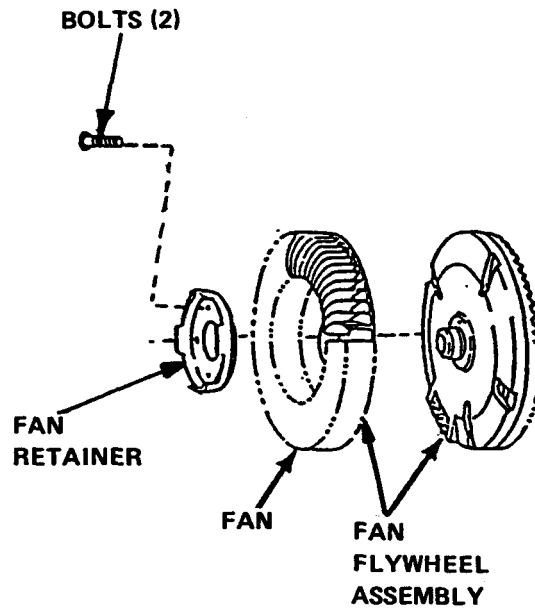

2. Remove two bolts and fan retainer.
3. Remove fan.

4-34. FLYWHEEL AND RING GEAR ASSEMBLY REPLACEMENT (CONT)

ASSEMBLY

1. Install fan on flywheel.
2. Install two bolts and fan retainer.

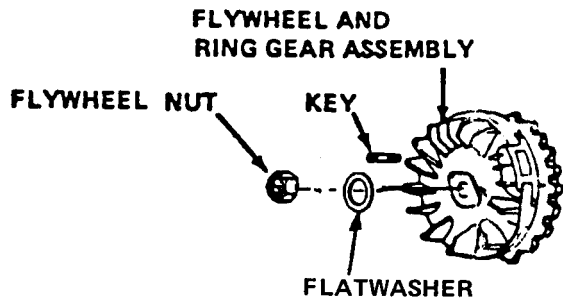

INSTALL

1. Install key in keyway of flywheel.
2. Install flywheel on crankshaft making sure to aline keyways.
3. Install flywheel nut and flatwasher.

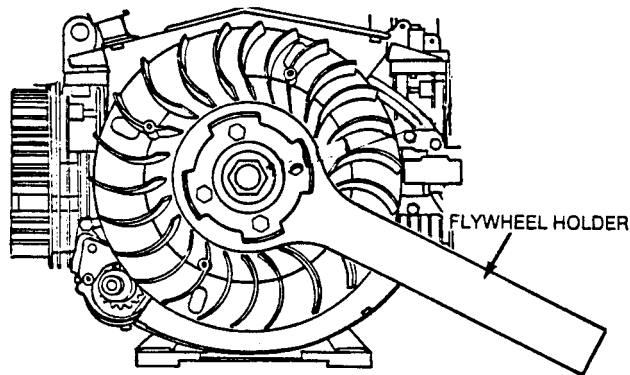

4. Use flywheel holder on flywheel to prevent turning.
5. Torque flywheel nut to 150 ft lb (203 Nm).

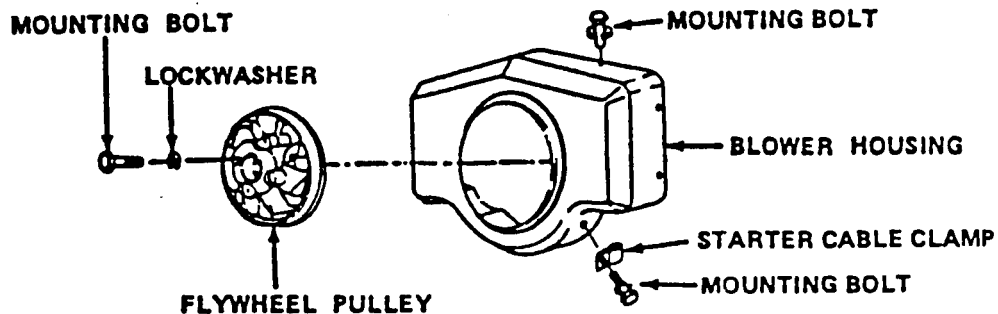

4-34. FLYWHEEL AND RING GEAR ASSEMBLY REPLACEMENT (CONT)

8. Install blower housing. Install eight blower housing mounting bolt, starter panel assembly and starter cable clamp.
9. Install flywheel pulley. Install two lockwashers and two flywheel pulley mounting bolts.

4-35. HIGH PRESSURE SWITCH CONTINUITY TEST.

DESCRIPTION

This task covers testing only.

INITIAL SETUP

<u>Equipment Condition Para</u>	<u>Condition Description</u>	<u>Tools</u>
2-8	Engine stopped.	Multimeter, item 2, Appendix B
4-15	Housing removed.	

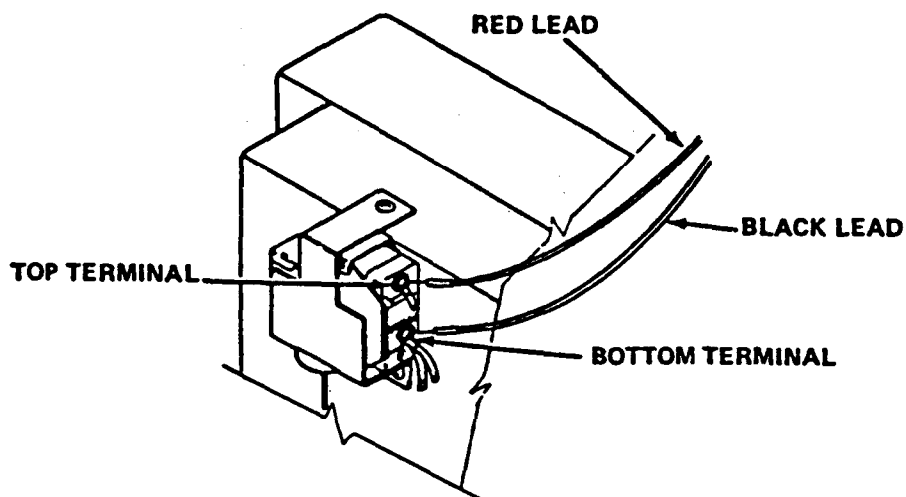

TEST

1. Prepare multimeter for continuity testing.
2. Remove single wire for testing.

4-35. HIGH PRESSURE SWITCH CONTINUITY TEST (CONT)

3. Place red lead of multimeter to top terminal of switch. Place black lead on bottom terminal of switch.
4. Multimeter should show greater than 1 ohm. If multimeter does not show proper continuity, notify Direct Support.
5. Attach single wire to switch.

4-36. LOW PRESSURE SWITCH CONTINUITY TEST.

DESCRIPTION

This task covers testing only.

INITIAL SETUP

<u>Equipment Condition Para</u>	<u>Condition Description</u>	<u>Tools</u>
2-8	Engine stopped.	Multimeter, item 2, Appendix B
4-15	Housing removed.	

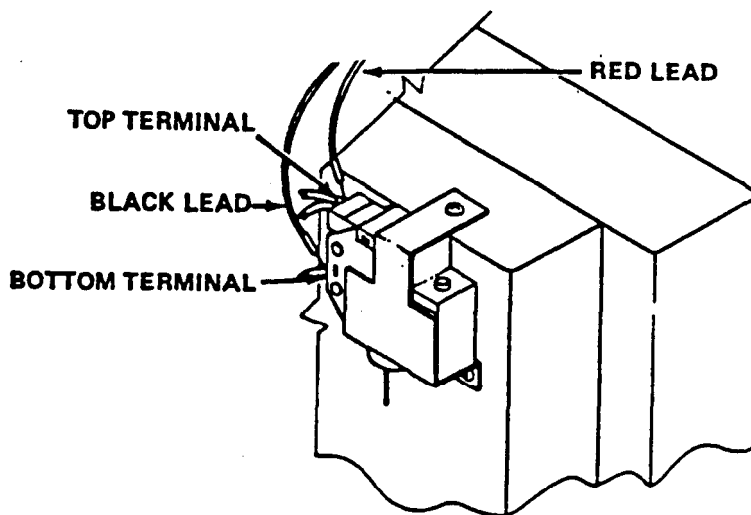

TEST

1. Prepare multimeter for continuity testing.
2. Remove single wire for testing.

4-36. LOW PRESSURE SWITCH CONTINUITY TEST (CONT)

3. Hold red lead of multimeter to top terminal of switch. Place black lead on bottom terminal of switch.
4. Multimeter should show greater than 1 ohm. If multimeter does not show proper continuity, notify Direct Support.
5. Attach single wire to switch.

4-37. WATER PUMP REPLACEMENT.

DESCRIPTION

This task covers: Removal and Installation

INITIAL SETUP

Equipment
Condition

<u>Para</u>	<u>Condition Description</u>	<u>Tools</u>
2-8	Engine stopped.	Tool Kit, General Mechanic's, item 1, Appendix B
4-15	Housing removed.	
4-20	Water pump drivebelt removed.	<u>Materials/Parts:</u> Tape, Anti-seize, item 33, Appendix E Insulation, tube, para F-5 Tube, para F-6

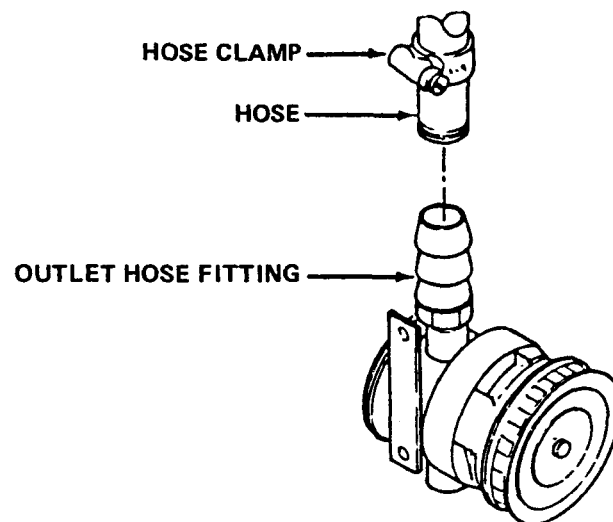

4-37. WATER PUMP REPLACEMENT (CONT)

REMOVAL

1. Pull back insulation on upper hose to expose hose clamp.
2. Loosen hose clamp.
3. Remove hose from outlet hose fitting.

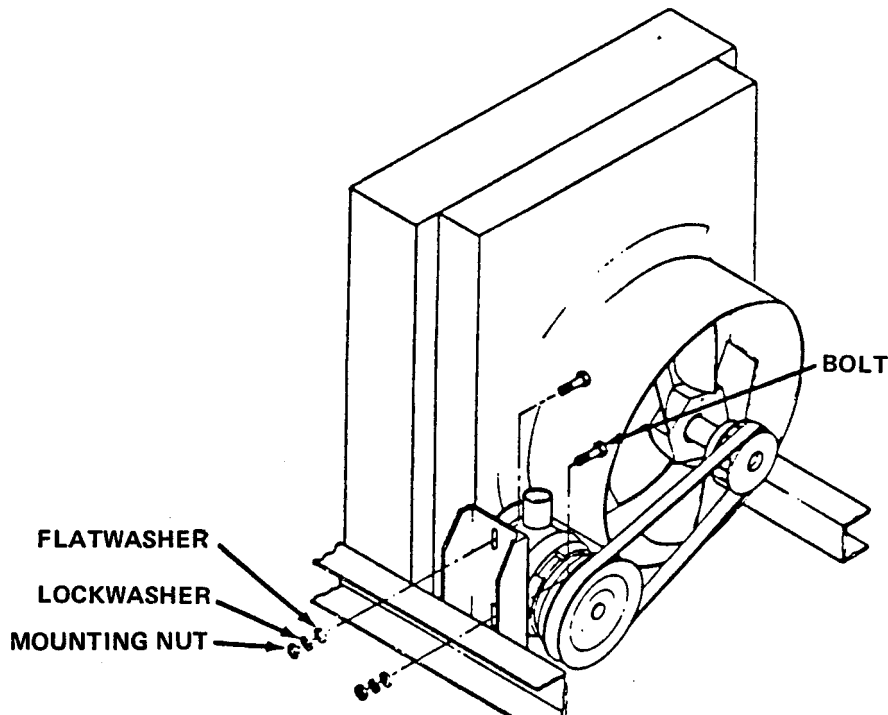

4. Remove two mounting nuts, two lockwashers, two flatwashers, and two bolts.
5. Lift and remove water pump.

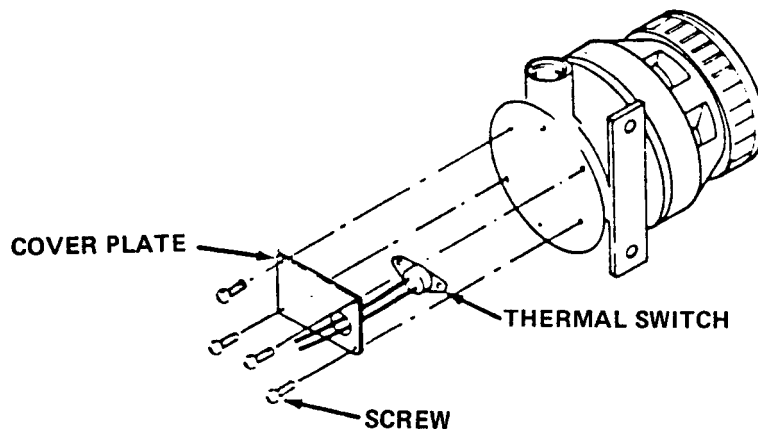

6. Tilt water pump to expose cover plate.

4-37. WATER PUMP REPLACEMENT (CONT)

7. Remove four screws from cover plate.
8. Remove cover plate and thermal switch.

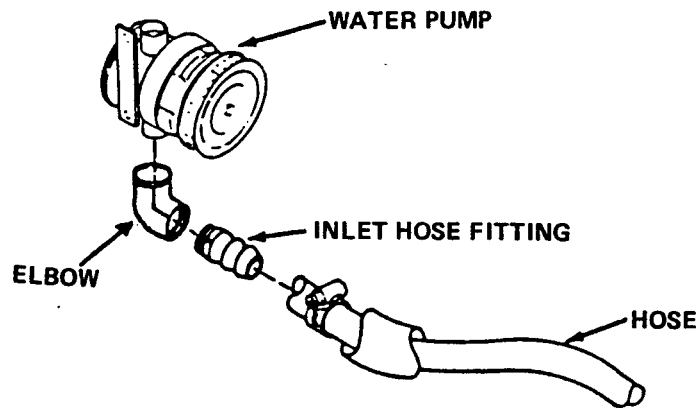

9. Pull back insulation on lower hose to expose hose clamp.
10. Loosen hose clamp.
11. Remove hose from fittings.
12. Remove water pump from water chiller.
13. Remove elbow and fittings.

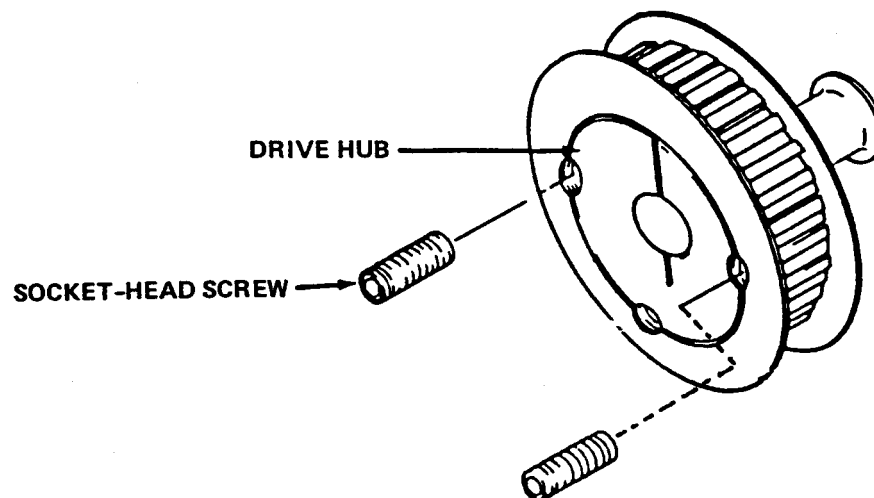

14. Remove two socket-head screws from water pump drive hub.

4-37. WATER PUMP REPLACEMENT (CONT)

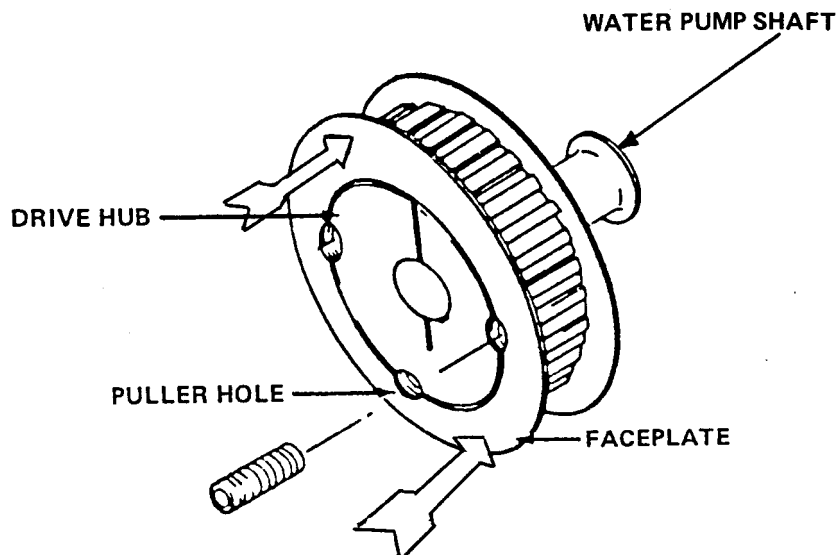

15. Install one socket-head screw in puller hole in water pump drive hub. Tighten socket-head screws while gently tapping on outer part of faceplate. Tighten screw and continue tapping until faceplate can be pushed back toward water pump and drive hub is lifted up.

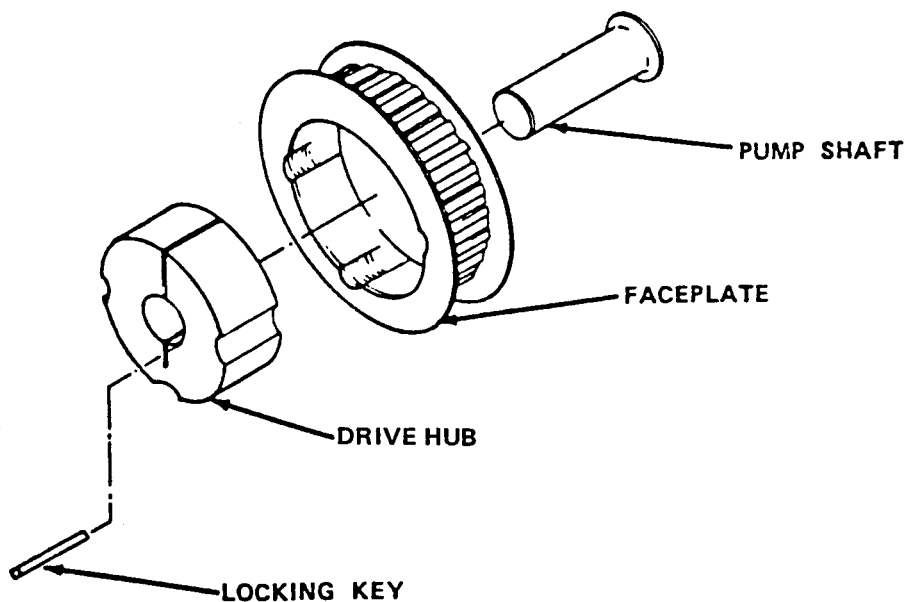

16. Remove drive hub and locking key from pump shaft.

4-37. WATER PUMP REPLACEMENT (CONT)

17. Remove faceplate from pump shaft.
18. Remove socket-head screw.

INSTALLATION
NOTE

Side of faceplate with three screw holes faces away from pump.

1. Place outer faceplate on water pump shaft against body of water pump.

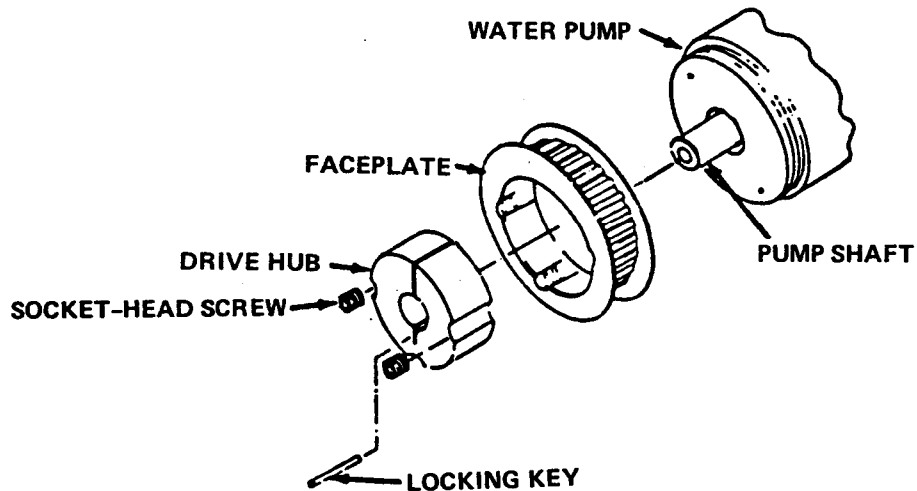

2. Place locking key in slot on water pump shaft.
3. Install drive hub on end of water pump shaft in alignment with locking key.
4. While sliding drive hub back on water pump shaft, place faceplate loosely on drive hub.
5. Push water pump drive hub assembly back against water pump. Adjust to provide clearance of at least 0.010 in. (0.25 mm) between assembly and water pump.
6. Install two socket-head screws in faceplate.

4-37. WATER PUMP REPLACEMENT (CONT)

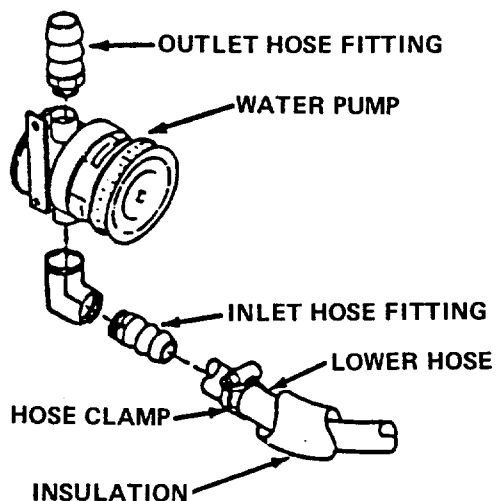

7. Wrap the threads of the water pump inlet and outlet hose fittings with teflon tape.

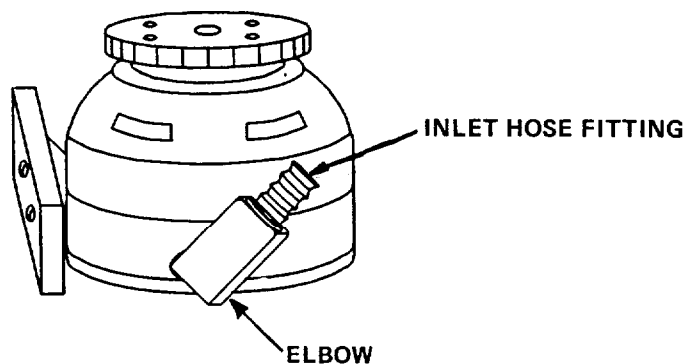

8. Install inlet and outlet hose fittings in water pump. Elbow must be in the position shown above.
9. Position water pump in frame of water chiller.
10. Install lower hose and hose clamp on water pump inlet hose fitting.
11. Tighten hose clamp. Pull insulation over hose clamp.

4-37. WATER PUMP REPLACEMENT (CONT)

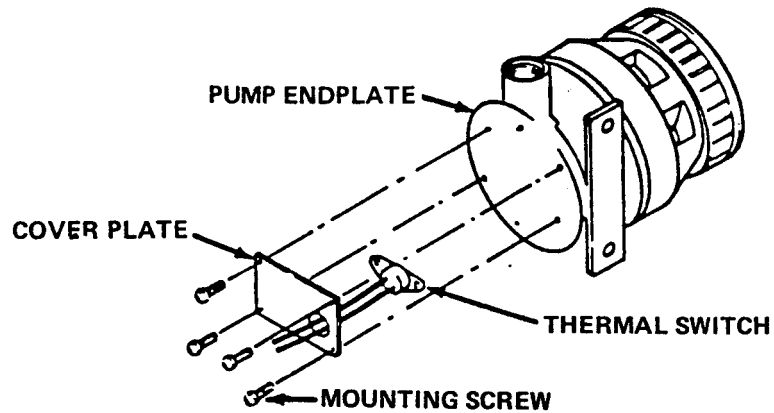

12. Install high temperature thermal switch and cover plate on pump endplate.
13. Install four switch bracket mounting screws.

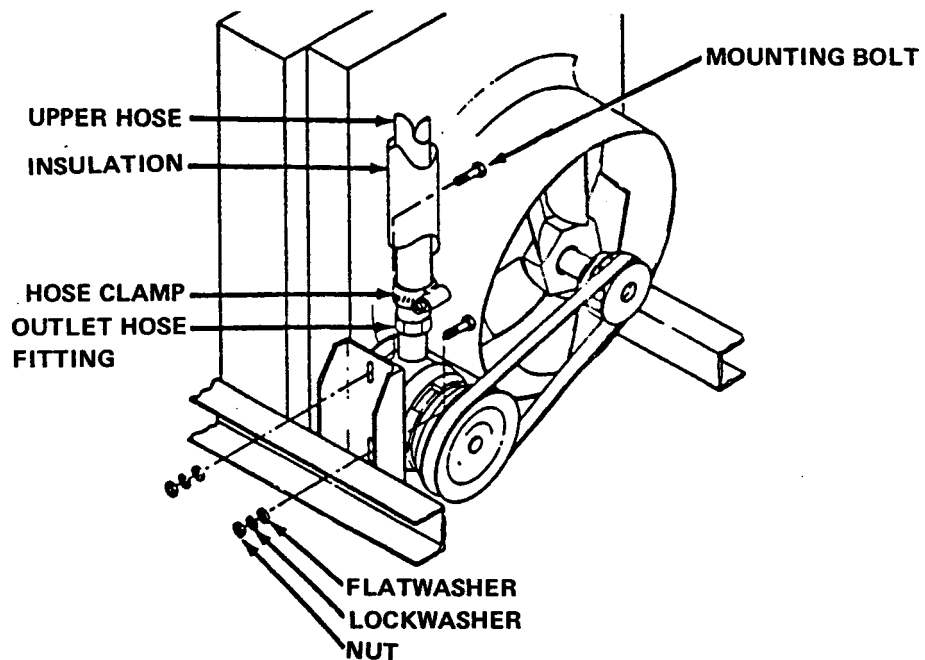

14. Install two water pump mounting bolts, two flatwashers, two lockwashers, and two nuts. Do not tighten.
15. Pour potable water into water pump outlet hose fitting to wet impeller.

4-37. WATER PUMP REPLACEMENT (CONT)

- 16. Install upper hose and hose clamp on water pump outlet hose fitting.
- 17. Tighten hose clamp. Pull insulation over hose clamp.
- 18. Install and adjust water pump drivebelt (para 4-20).

4-38. HIGH TEMPERATURE THERMAL SWITCH REPLACEMENT.

DESCRIPTION

This task covers: Testing, Removal, and Installation

INITIAL SETUP

Equipment Condition Para	Condition Description	Tools
2-8	Engine stopped.	Multimeter, item 2, Appendix B
4-15	Housing removed.	Gun, soldering, item 2, Appendix B
4-37	Water pump removed.	

Materials/Parts:

Solder, item 30, Appendix E

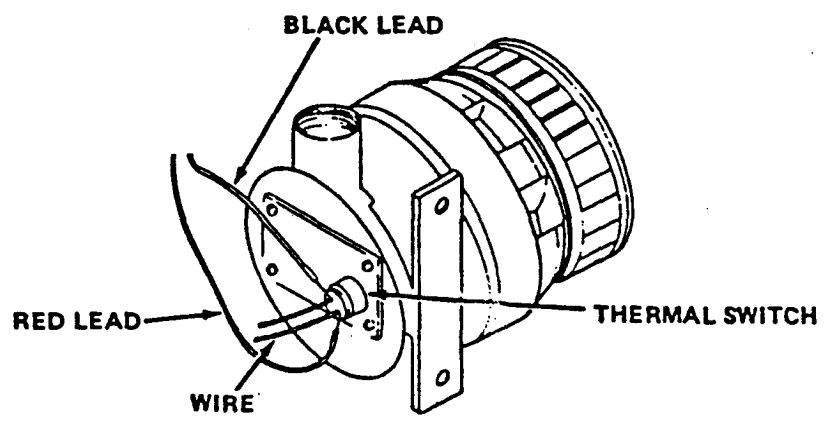

TESTING

- 1. Check that water temperature is below 120°F (49°C).

4-38. HIGH TEMPERATURE THERMAL SWITCH REPLACEMENT (CONT)

2. Locate two terminals on back of high temperature thermal switch.
3. Place multimeter red lead on one terminal. Place black lead on other terminal. Multimeter should show more than 1 ohm.
4. If multimeter does not show more than 1 ohm, replace switch.

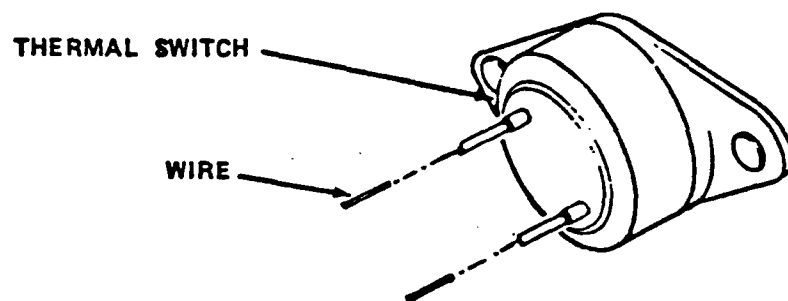
REMOVAL

Unsolder two wires from thermal switch. Remove thermal switch.

INSTALLATION**NOTE**

Ensure COVER PLATE is on WIRE HARNESS before soldering.

1. Install new thermal switch. Solder two wires to thermal switch terminals.
2. Install water pump (para 4-37).

4-39. RELIEF VALVE ADJUSTMENT.

DESCRIPTION

This task covers adjustment only.

INITIAL SETUP

Equipment Condition Para	Condition Description	Tools
2-8	Engine stopped.	Tool Kit, General Mechanic's, item 1, Appendix B
4-15	Housing removed.	

Materials/Parts:

Pail, Appendix D

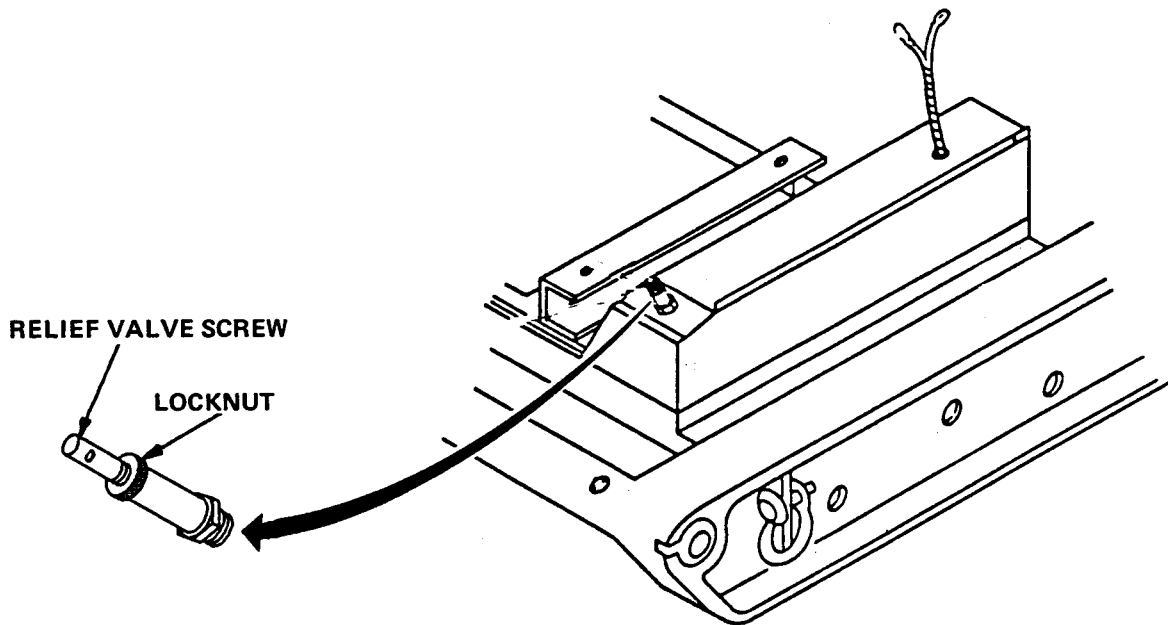

ADJUSTMENT

1. Loosen locknut on relief valve.
2. Disconnect COOL RECIRCULATE hose from water supply and place near pail.
3. Start up water chiller (para 2-8b). Turn START RUN water control to START position.

4-39. RELIEF VALVE ADJUSTMENT (CONT)

4. Measure time it takes to fill pail. If relief valve is properly adjusted, it should take 10 seconds to fill pail.
5. Turn relief valve screw right (clockwise) to decrease flow. Turn left (counterclockwise) to increase flow.
6. Adjust until proper flow rate is achieved. If proper flow rate can not be achieved, notify Direct Support.
7. Tighten locknut on relief valve, being careful not to disturb adjustment of relief valve screw.

4-40. LOW TEMPERATURE THERMAL SWITCH TEST.

DESCRIPTION

This task covers testing only.

INITIAL SETUP

Equipment
Condition
Para

Condition Description

Tools

2-8

Engine stopped.

Multimeter, item 2,
Appendix B

4-15

Housing removed.

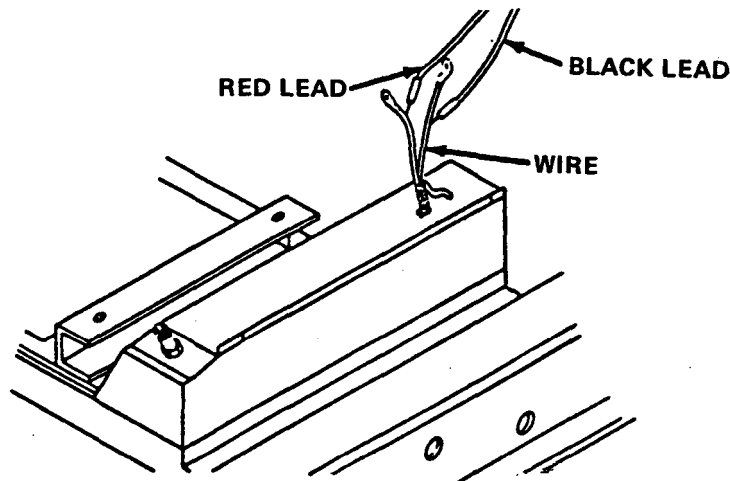

TESTING

1. Check that water supply temperature is above 65°F (18°C).

4-40. LOW TEMPERATURE THERMAL SWITCH TEST (CONT)

2. Unwrap wire harness cover to locate two wire from low temperature thermal switch. Disconnect wires from toggle switch S3 and pneumatic timer switch S8.
3. Place multimeter red lead on one wire. Place black lead on other wire. Multimeter should show more than 1 ohm.
4. If multimeter shows less than 1 ohm, notify Direct Support to replace switch.

4-41. STARTING CONNECTION ASSEMBLY REPLACEMENT.

DESCRIPTION

This task covers: Testing, Removal, and Installation

INITIAL SETUP

Equipment
Condition

<u>Para</u>	<u>Condition Description</u>	<u>Tools</u>
2-8	Engine stopped.	Tool Kit, General
4-15	Housing removed.	Mechanic's, item 1, Appendix B
4-1	Crankcase oil drained.	Tap and Die Set (5136-01-119-0005)
4-21	Compressor drivebelt removed.	item 3, Appendix B

Materials/Parts:

Tags, item 32, Appendix E
 Oil, lubricating, item 17, Appendix E
 Lockwasher MS35338-46
 Lockwasher MS35338-138
 Sealant, compound, item 27, Appendix E

4-41. STARTING CONNECTION ASSEMBLY REPLACEMENT (CONT)

TESTING

1. Using multimeter, check power cable for 12 volts power source. If correct voltage is present, go to step 2. If correct voltage is not present, obtain correct voltage before going to next step.
2. Connect power cable to 12/24 INPUT POWER FOR STARTING connection.

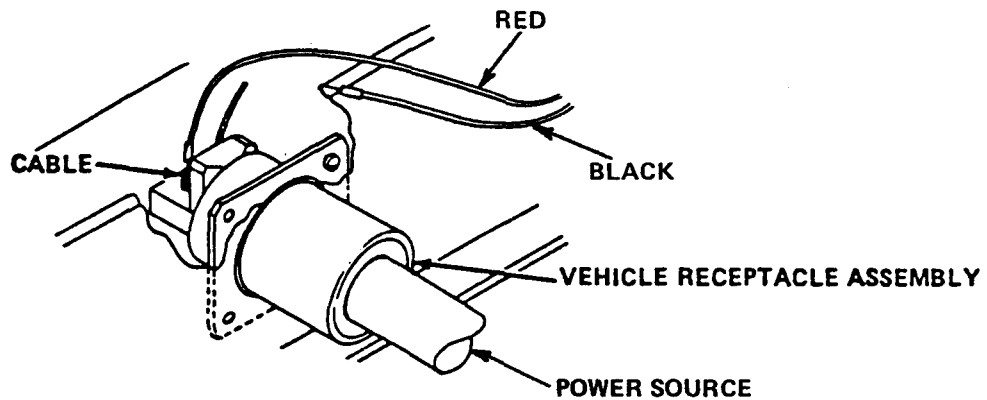

3. Using multimeter, check back of STARTING connection assembly for 12 volts. If correct voltage is not present, replace assembly.

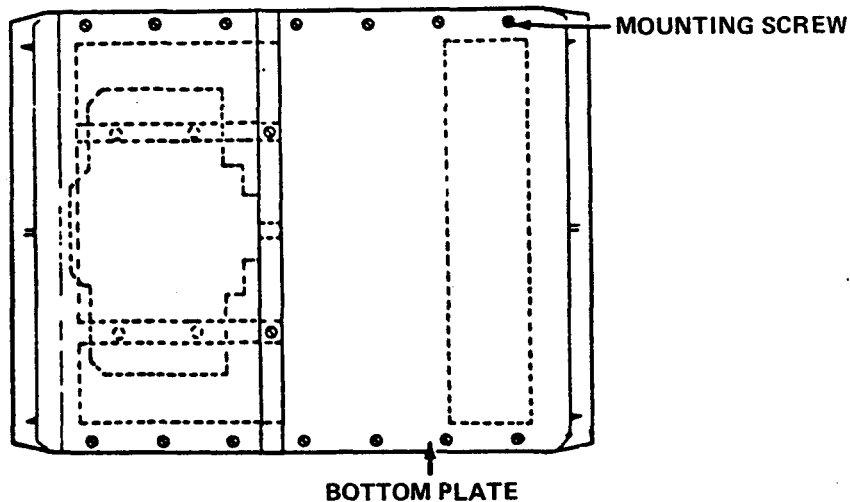

REMOVAL

1. Drain engine oil (para 4-1).
2. Turn water chiller on its side with STARTING connection assembly up.

4-41. STARTING CONNECTION ASSEMBLY REPLACEMENT (CONT)

3. Remove 16 bottom plate mounting screws. Remove bottom plate. Clean threads in skid base using tap.

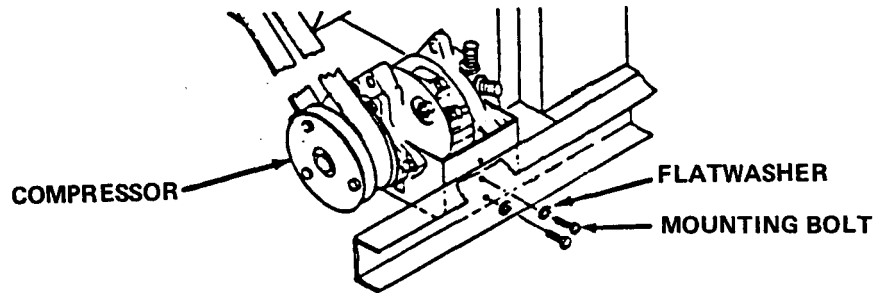

4. Remove two compressor bracket mounting bolts and two flatwashers. Move compressor aside.

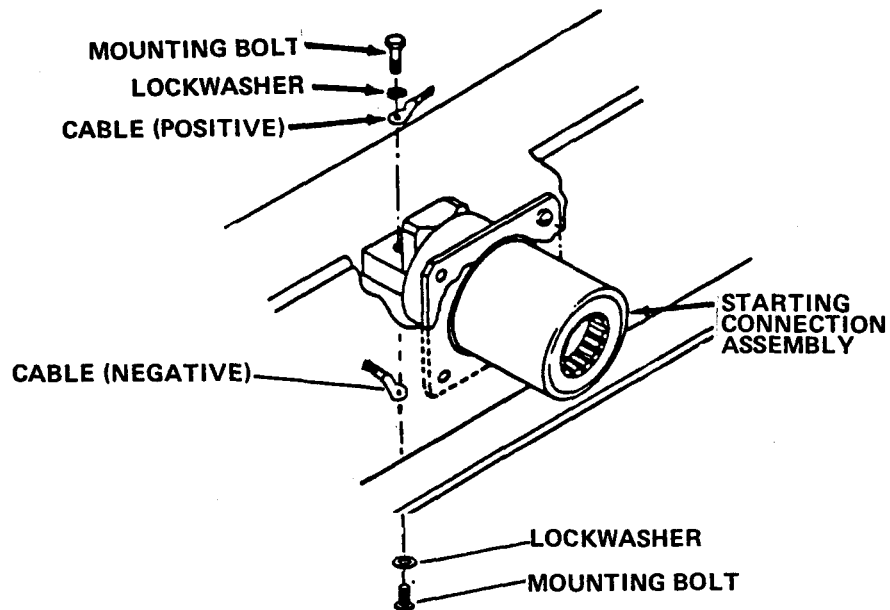

5. Tag cables. Remove cable mounting bolts and lockwashers from STARTING connection assembly.
6. Remove cables.

4-41. STARTING CONNECTION ASSEMBLY REPLACEMENT (CONT)

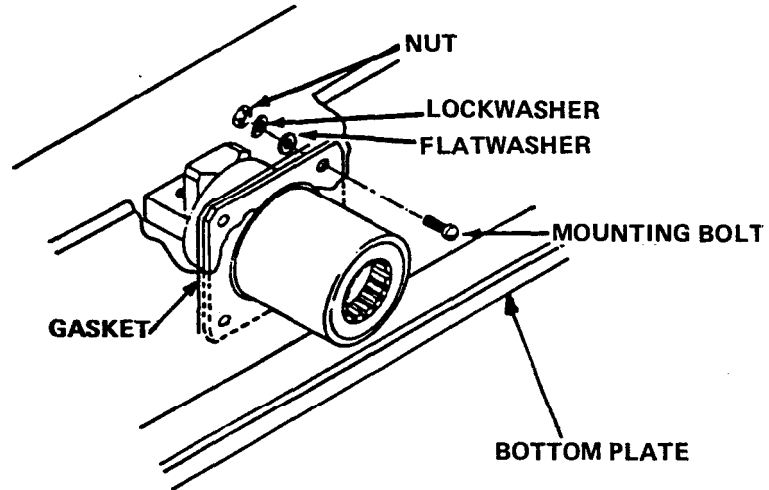

7. Remove four STARTING connector assembly mounting bolts, flatwashers, lockwashers, nuts, and gasket.
8. Remove STARTING connection assembly.

INSTALLATION

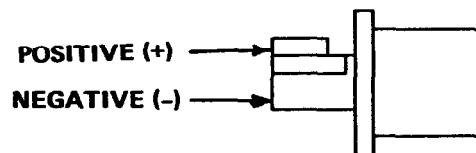

SIDE VIEW OF STARTING CONNECTOR

1. Place STARTING connector assembly in proper position in skid.

4-41. STARTING CONNECTION ASSEMBLY REPLACEMENT (CONT)

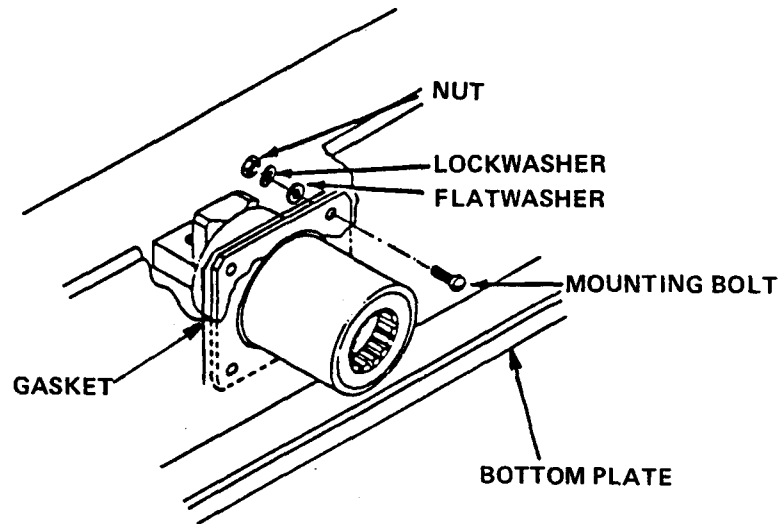

2. Install four mounting bolts, four flatwashers, four lockwashers, four nuts, and gasket.

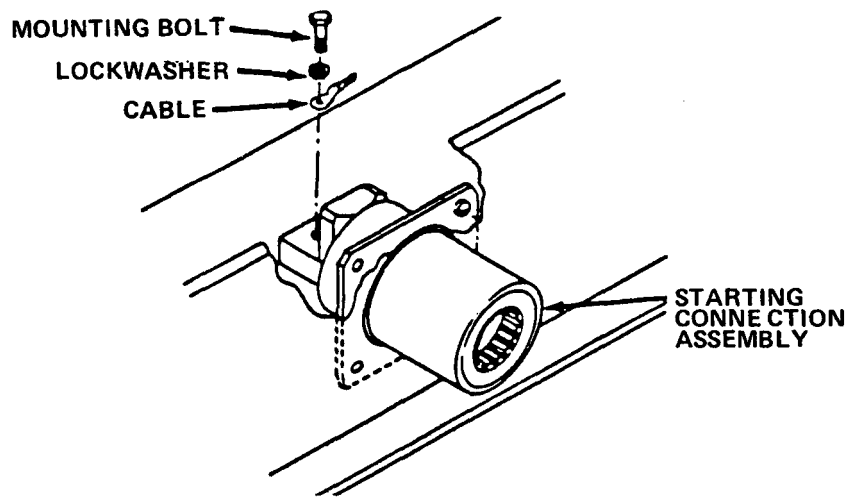

3. Install electric cable in vehicle receptacle assembly.
4. Install lockwasher and cable on mounting bolt. Install mounting bolt .

4-41. STARTING CONNECTION ASSEMBLY REPLACEMENT (CONT)

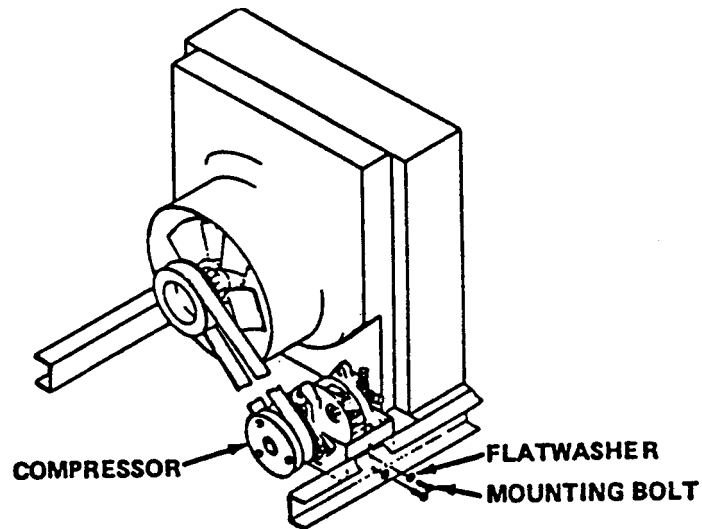

5. Align compressor bracket with mounting holes. Install compressor bracket mounting bolts and flatwashers.

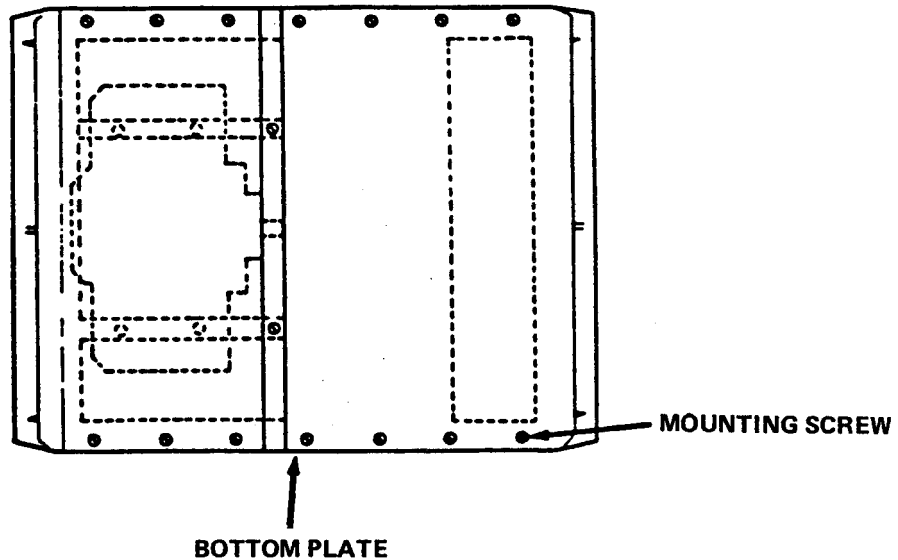

6. Install bottom plate. Install 16 bottom plate mounting screws using sealing compound.
7. Turn water chiller upright.
8. Adjust compressor drivebelt (para 4-21).
9. Add engine oil (para 4-1).

4-42. SKID REPAIR (CARRYING HANDLES).

DESCRIPTION

This task covers: Removal and Installation.

INITIAL SETUP

Equipment Condition Para	Condition Description	Tools
2-8	Engine stopped.	Tool Kit, General Mechanic's, item 1, Appendix B
4-15	Housing removed.	

Material/Parts:

Lockwasher MS35338-138

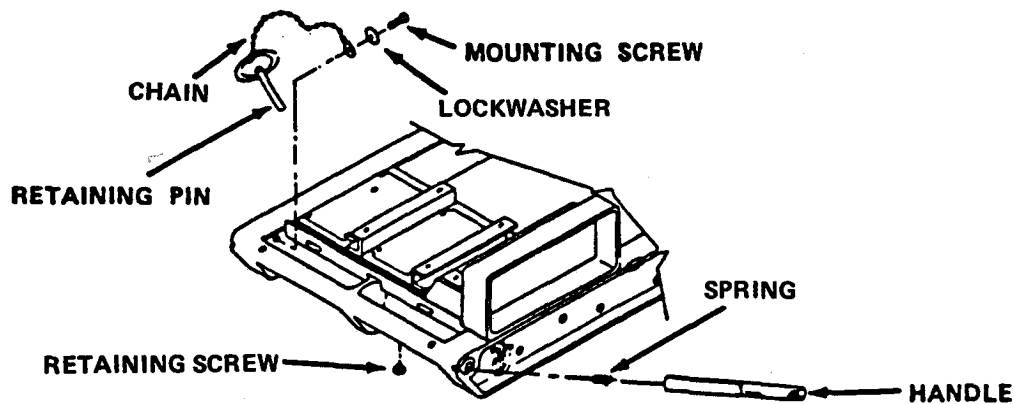

REMOVAL

1. Pull out retaining pin. Leave handle in extended position.
2. Remove retaining pin chain mounting screw and lockwasher.
3. Remove retaining pin assembly.
4. Remove handle retaining screw.
5. Remove handle and spring. Remove spring from end of handle.

4-42. SKID REPAIR (CARRYING HANDLE) (CONT)

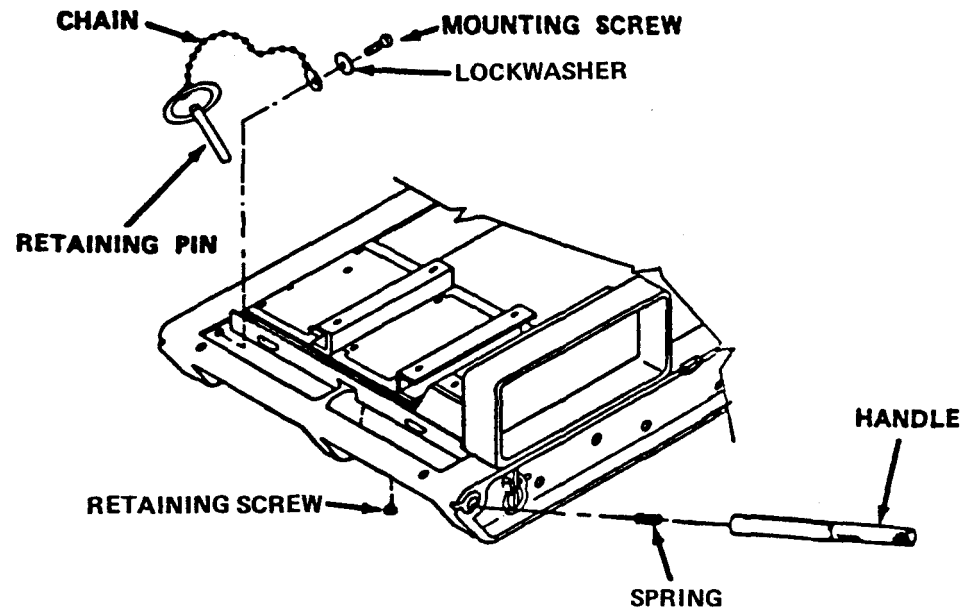
**INSTALLATION**

1. Insert spring in end of handle.
2. Install handle and spring in skid with retaining screw slot down.
3. Install handle retaining screw.
4. With handle in retracted position, insert retaining pin through skid and handle. Handle should now remain in retracted position.
5. Install retaining pin chain on skid assembly.
6. Install retaining pin chain lockwasher and mounting screw.

4-43 FUEL HOSE REPAIR

DESCRIPTION

This task covers: Disassembly and Assembly.

INITIAL SETUP

Tools

Tool Kit, General Mechanic's
item 1, Appendix B

Materials/Parts:

Hose, para F-7
Hose, para F-8
Tube, Copper, para F-9
Tape, Anti-seize, item 33,
Appendix B

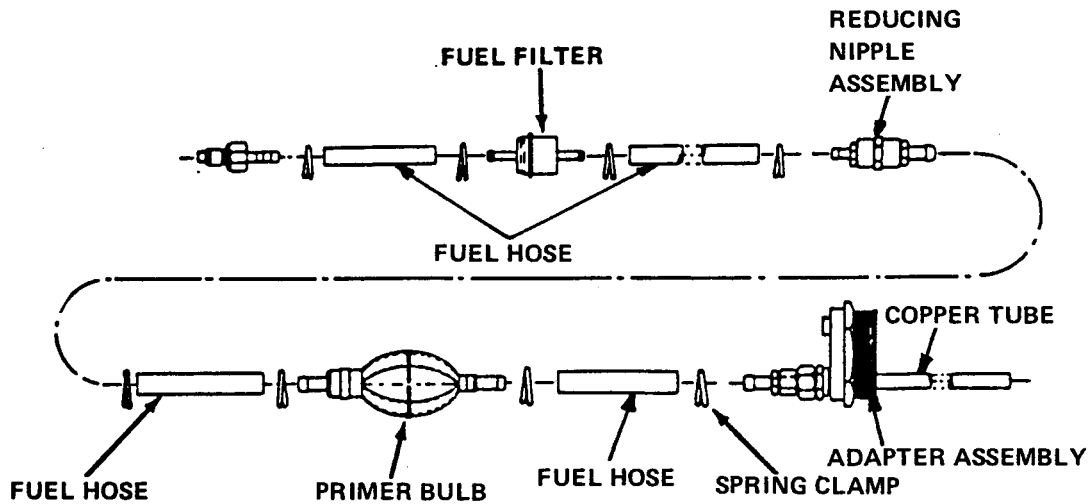

DISASSEMBLY

Remove spring clamps. Remove fuel hose, adapter assembly, fuel filter, reducing nipple assembly, or primer bulb.

ASSEMBLY

1. Install new fuel filter, adapter assembly, reducing nipple assembly, or primer bulb. Replace fuel hose with bulk hose.
2. Install hose spring clamps.

4-44. WATER HOSE REPAIR.

DESCRIPTION

This task covers: Disassembly and Assembly.

INITIAL SETUPTools

Tool Kit, General Mechanic's,
item 1, Appendix B

Materials/Parts:

Hose, para F-6

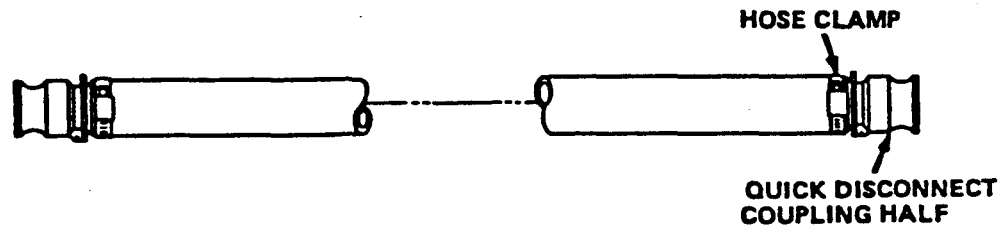
**DISASSEMBLY**

1. Loosen hose clamp. Remove quick-disconnect coupling half from hose.
2. Remove hose clamp. Place hose clamp on new hose section.

ASSEMBLY

1. Install quick-disconnect coupling half in new hose.
2. Install hose clamp over quick-disconnect coupling half.

4-45. BREATHER ASSEMBLY REPLACEMENT.

DESCRIPTION

This task covers: Removal, Inspection, and Installation.

INITIAL SETUP

Equipment
Condition
Para

Condition Description

Tools

2-8	Engine stopped.	Tool Kit, General
4-15	Housing removed.	Mechanic's, item 1, Appendix B
4-27	Carburetor and intake manifold assembly removed.	Gaskets (08645) 27803 Lockwasher MS35333-38
4-32	Dipstick removed.	

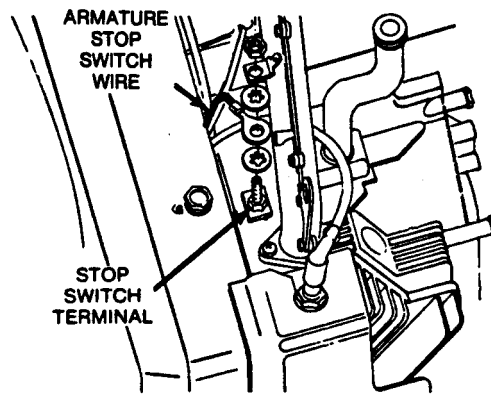

REMOVAL

1. Remove nut securing stop wires to terminal on right breather.

4-45. BREATHER ASSEMBLY REPLACEMENT (CONT)

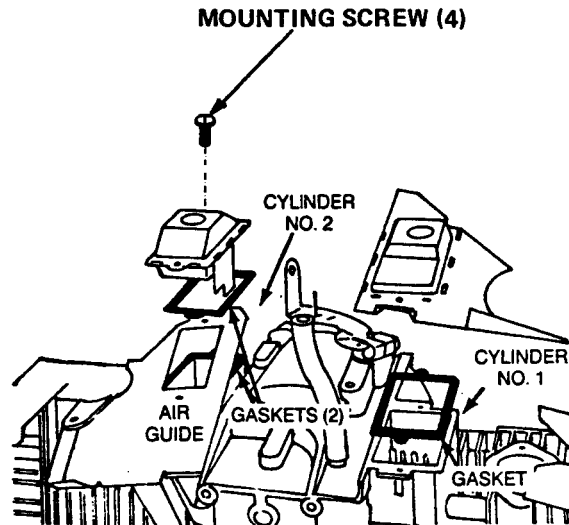

2. Remove four screws holding breathers to engine assembly.
3. Remove breathers.
4. Remove air guide (cylinder No. 2). Remove and discard gaskets.

INSPECTION

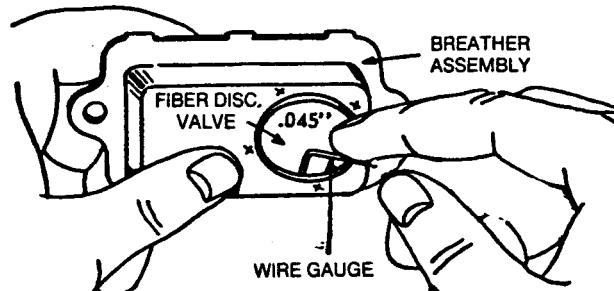

1. Check fiber disc valve for movement. If the fiber disc valve is stuck or binding, the breather cannot function properly and must

4-45. BREATHER ASSEMBLY REPLACEMENT (CONT)

be replaced. A 0.045 inch wire gauge should not enter the space between the fiber disc valve and body. (A spark plug wire gauge may be used.) DO NOT FORCE GAUGE.

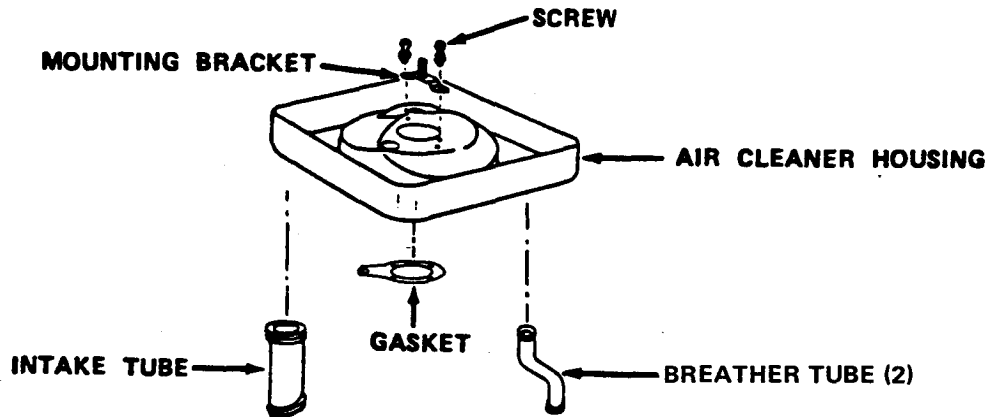

2. Inspect two breather tubes attached to air cleaner housing. Check breather tubes are not damaged or blocked and seal properly.

INSTALLATION

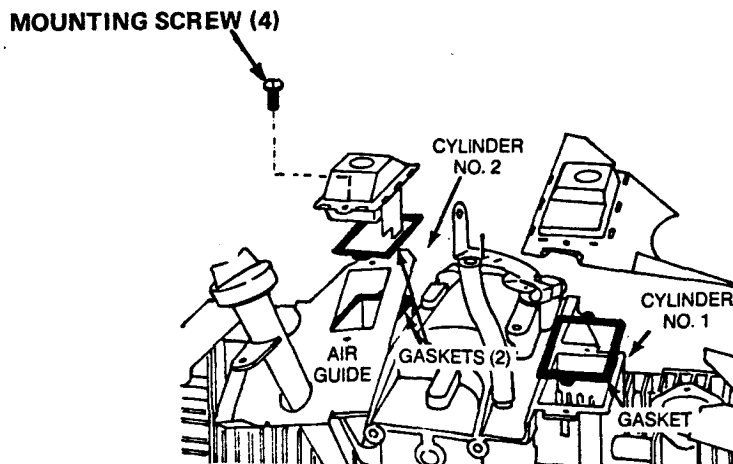

1. Install air guide (cylinder no. 2) to breather.

4-45. BREATHER ASSEMBLY REPLACEMENT (CONT)

2. Install three new gaskets.
3. Install breathers.
4. Attach breathers using four screws to engine assembly.

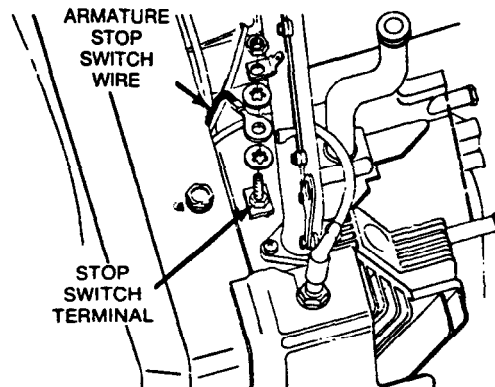

5. Attach stop wires to terminal on right breather with lockwasher and nut.
6. Install dispstick tube assembly (para 4-32).
7. Install carburetor and intake manifold assembly (para 4-27).

Section VII. PREPARATION FOR STORAGE OR SHIPMENT

4-46. STORAGE AND SHIPMENT INSTRUCTIONS

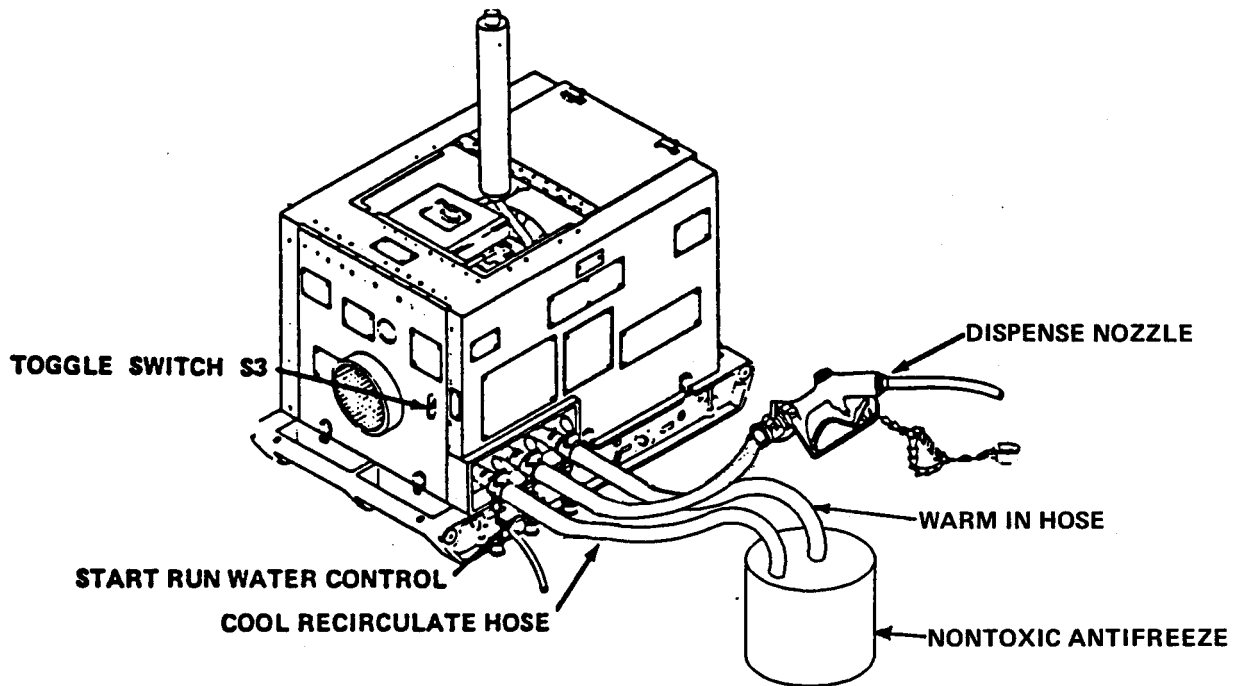

1. Disconnect WARM IN and COOL RECIRCULATE hoses from water storage tank. Place both ends of disconnected hoses in a 5 gallon container of nontoxic antifreeze (minimum 4 gallons) (item 5, Appendix E).
2. Start up engine (para 2-8b).
3. Open dispense nozzle over antifreeze container.

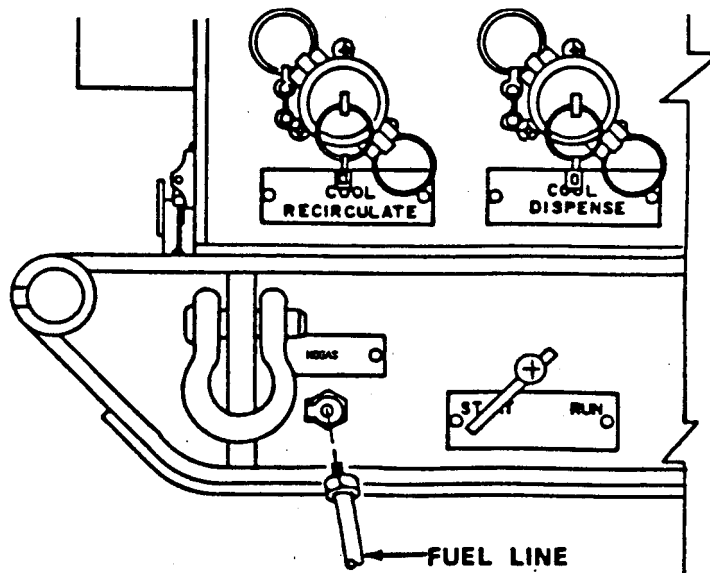

4-46. STORAGE AND SHIPMENT INSTRUCTIONS (CON'T)

- When antifreeze begins to run from nozzle and COOL RECIRCULATING hoses, disconnect fuel hose from skid. Hold toggle switch in START position until engine runs out of fuel. Release toggle switch S3. Place START-RUN water control in START position.

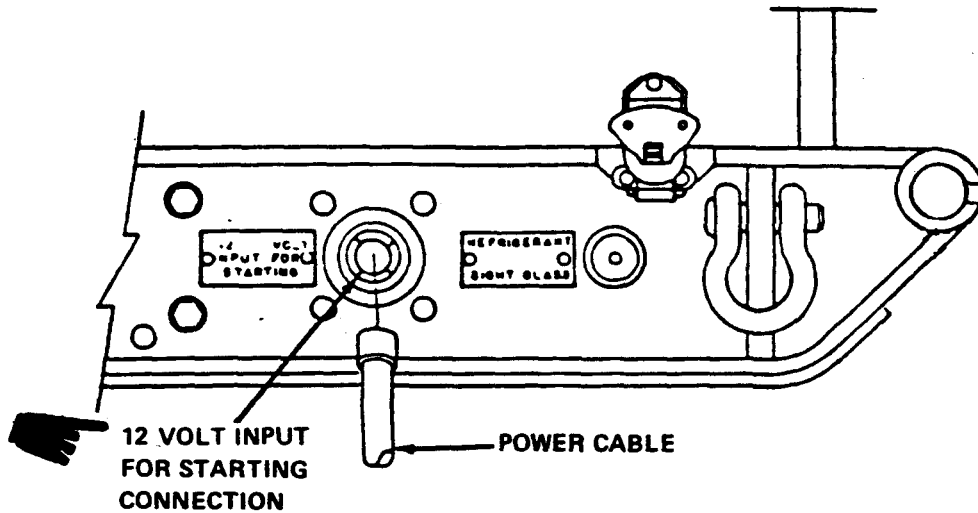

- If used, disconnect power cable from 12 VOLT INPUT FOR STARTING connection.

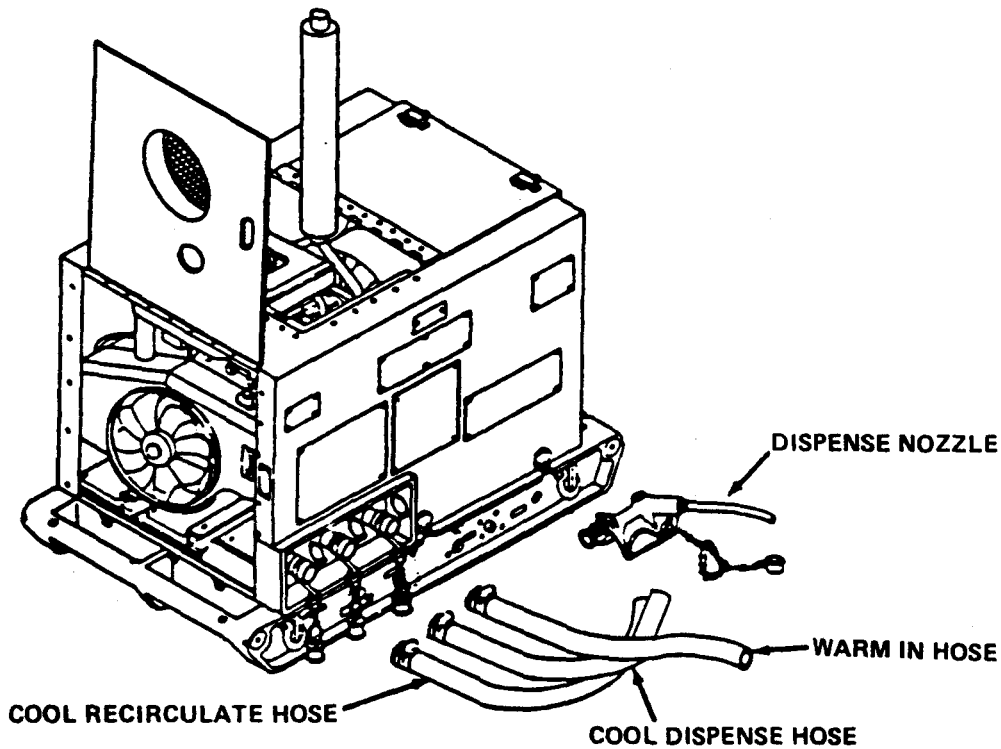

4-46. STORAGE AND SHIPMENT INSTRUCTIONS (CONT)

6. Remove all hoses from water chiller and antifreeze container.

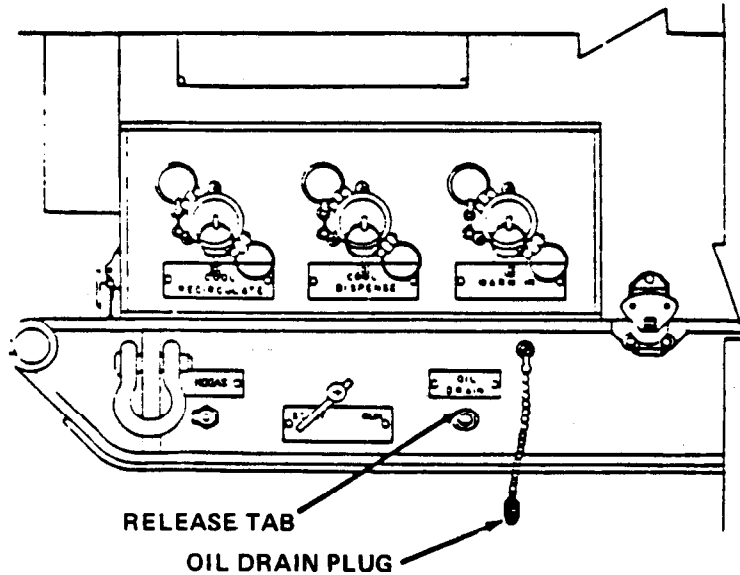

7. Drain all hoses.
8. With engine still warm, place oil drain pan (Appendix D) under OIL DRAIN.
9. Press release tab, pull plug, and let oil drain. Install plug. Discard waste oil.
10. Pull out dipstick. Fill engine with 3.0 pints (1.42 liters) of oil, (item 17, Appendix E) through tube. Install dipstick.

4-46. STORAGE AND SHIPMENT INSTRUCTIONS (CONT)

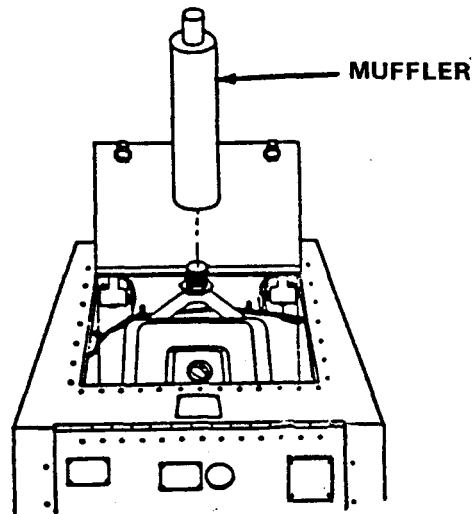
**WARNING**

To prevent burns, DO NOT try to remove muffler until it cools down.

11. Remove muffler.
12. Place hoses, dispense nozzle, fuel line, and muffler in support kit duffle bag.

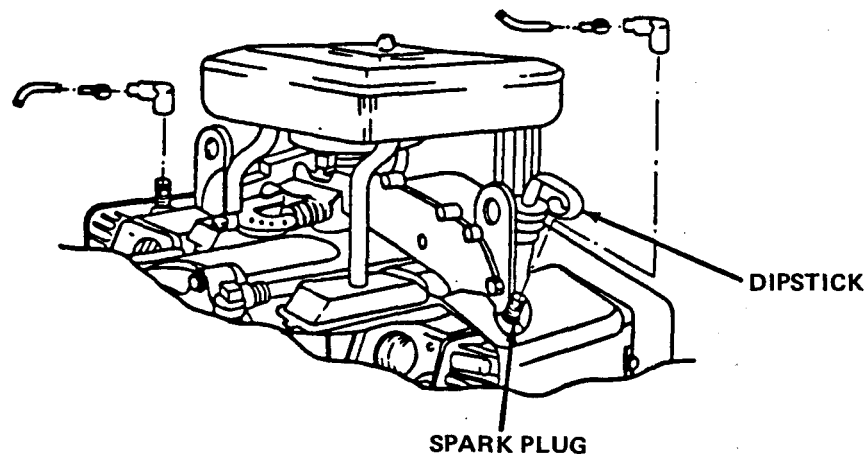

13. Remove spark plugs and pour 1 oz (30 cc) of oil (item 7, Appendix E) into each cylinder. Rotate engine slowly by hand to distribute oil. Install two spark plugs.

4-46. STORAGE AND SHIPMENT INSTRUCTIONS (CONT)

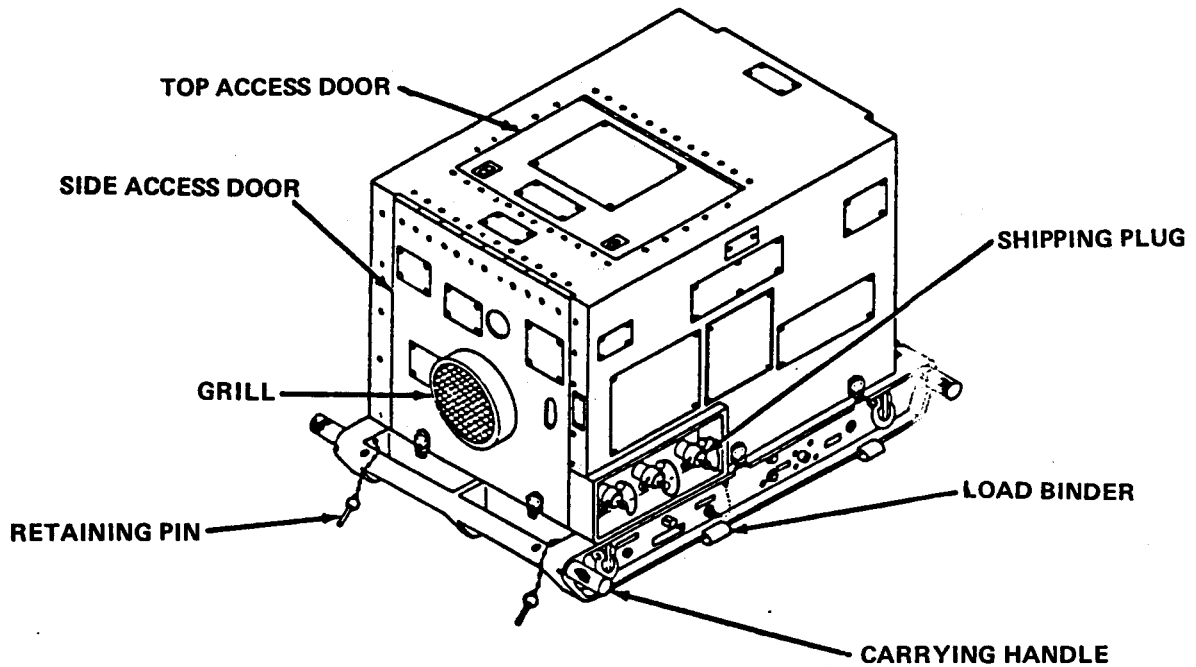

14. Clean all debris from grilles.
15. Close and fasten top and side access doors.
16. Insert shipping plugs in water openings and secure in place.
17. If water chiller is mounted on trailer, unbolt grab hooks.
18. Pull out four retaining pins. Pull out four carrying handles.

WARNING

To prevent personal injury, four persons required to lift water chiller.

19. Slide water chiller out of trailer mounting bracket.
20. Place water chiller in shipping container.
21. Place support kit duffle bag in shipping container.

CHAPTER 5

DIRECT SUPPORT MAINTENANCE

INDEX

SECTION	TITLE	PAGE
I.	TROUBLESHOOTING	5-1
II.	GENERAL MAINTENANCE PROCEDURES	5-3
III.	MAINTENANCE PROCEDURES	5-19

Section I. TROUBLESHOOTING

5-1. GENERAL. Table 5-1, Troubleshooting, lists common malfunctions which may be found during normal operation or during an inspection, check procedure, or scheduled testing. Perform the tests/inspections and corrective actions in order listed. This manual cannot list all malfunctions that may occur or list all tests/inspections and corrective actions. If a malfunction occurs that is not listed or covered in corrective action, notify your supervisor.

Table 5-1. Troubleshooting

MALFUNCTION

TEST OR INSPECTION

CORRECTIVE ACTION

1. ENGINE STOPS SUDDENLY.

Step 1. Test high and low pressure switch assemblies for continuity (para 4-35 and 4-36).

Replace switch (para 5-17 or 5-18).

Step 2. Test low temperature thermal switch for continuity (para 4-40).

Replace switch (para 5-32).

2. WATER LEAKS FROM FOAMED-IN SECTION OF SKID.

Step 1. Check for cracked evaporator.

Replace evaporator (para 5-27).

Table 5-1. Troubleshooting (Cont)

MALFUNCTION	TEST OR INSPECTION	CORRECTIVE ACTION
-------------	--------------------	-------------------

2.	WATER LEAKS FROM FOAMED-IN SECTION OF SKID (cont)	
	Step 2. Check for leak at thermostatic valve.	Replace thermostatic valve (para 5-29).
	Step 3. Check for leaking START RUN valve.	Replace START RUN valve (para 5-31).
3.	ENGINE SMOKES EXCESSIVELY OR LEAKS OIL.	
	Step 1. Test engine compression (para 4-25).	Replace cylinder block assembly (para 5-6).
	Step 2. Check cylinder block assembly for cracks.	Replace cylinder block assembly (para 5-6).
	Step 3. Check cylinder block for leaking seals and gaskets.	Replace cylinder block assembly (para 5-6).
4.	PRODUCT WATER NOT COOL.	
	Step 1. Check refrigerant system pressure (para 5-14).	Recharge system (para 5-13).
	Step 2. Check for refrigerant leaks (para 5-11).	Repair leaks (para 5-8).
5.	REFRIGERATION SYSTEM CONTINUOUSLY LOSING REFRIGERANT.	
	Step 1. Check refrigerant tubing and components for leaks (para 5-6).	Repair or replace as required.
	Step 2. Check pressure relief valve (para 5-18).	Replace if defective (para 5-18).

Section II. GENERAL MAINTENANCE PROCEDURES

5-2. GENERAL.

a. Scope. This section contains Direct Support Maintenance instructions authorized by the Maintenance Allocation Chart (MAC), Appendix B, and by the Source, Maintenance, and Recoverability (SMR) coded items to support the water chiller.

b. Description.**WARNING**

When the refrigeration system must be opened for any reason, carefully discharge the refrigerant first. Avoid contact with liquid refrigerant. Severe freezing of body tissues can take place with extreme rapidity. Avoid excessive inhalation of refrigerant gas, and ventilate the area in which it is released. Refrigerant gas in contact with flame or hot surfaces is converted to phosgene. Phosgene is a highly toxic gas with an odor similar to newly mown grass or hay.

- 1 The refrigerant system is illustrated by the refrigerant flow diagram. It is a mechanical, vapor-cycle circuit made up of evaporator, thermal expansion valve, compressor, condenser, and the necessary valves and cutout devices for automatic control during operation.
- 2 The thermal expansion valve releases high-pressure liquid refrigerant into the evaporator at reduced pressure.
- 3 The liquid refrigerant begins to vaporize by absorbing heat from the water passing through the tubing of the evaporator.
- 4 The heated vapor is pulled from the evaporator section by the compressor, and forced into the condenser section under high Pressure. There it is cooled and condensed back into a liquid.
- 5 The heat released during condensation is carried off by the condensing airstream.
- 6 The liquid refrigerant flows from the condenser through a sight glass into the filter-drier and then to the thermal expansion valve to repeat the cycle.
- 7 If the temperature control switch (low temperature thermal switch) becomes satisfied, the switch will open, grounding the ignition system, and stopping the gasoline engine.

5-2. GENERAL (CONT)

c. Refrigeration System Repair. The refrigerant system must be discharged before any maintenance is performed on any system component. The following paragraphs (5-3 through 5-9) contain procedures detailing various aspects of the steps commonly taken to repair the refrigeration system. Do not try to re-use or repair seals and gaskets. New parts should always be used at assembly. When heating refrigeration piping to debraze or unsolder connections as well as to solder or braze them, the piping should be protected with a continuous flow of dry nitrogen to prevent scaling or oxidation of the inside surface. Leak testing and dehydrator replacement are required after any system component has been removed or replaced. The system must be evacuated before it is charged, and it must be properly charged to function as designed.

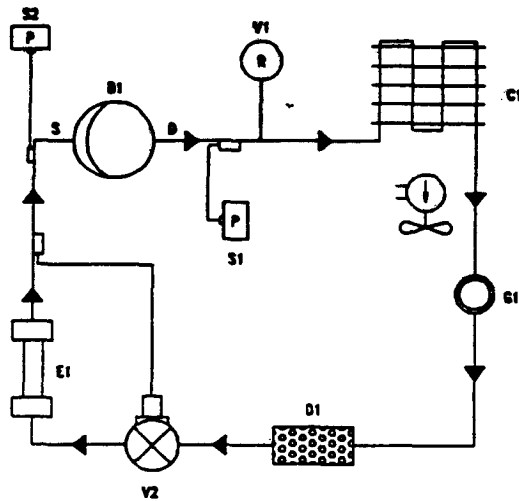

REF DES	QTY	NOMENCLATURE
B1	1	COMPRESSOR
C1	1	CONDENSER
D1	1	FILTER-DRYER
E1	1	EVAPORATOR
E1	1	SIGHT GLASS
V1	1	VALVE, PRESSURE RELIEF
V2	1	VALVE, EXPANSION
S1	1	SWITCH, PRESSURE
S2	1	SWITCH, PRESSURE

5-3. REFRIGERANT SYSTEM SERVICE - DISCHARGE.

DESCRIPTION

This task covers: Discharge

INITIAL SETUP

Equipment Condition Para

Condition Description

Tools

2-8

Engine stopped.

Tool Kit, Service Refrigeration, item 5, Appendix B

4-15

Housing removed.

Recovery and Recycling Unit, item 14, Appendix B

5-3. REFRIGERANT SYSTEM SERVICE-DISCHARGE (CONT)

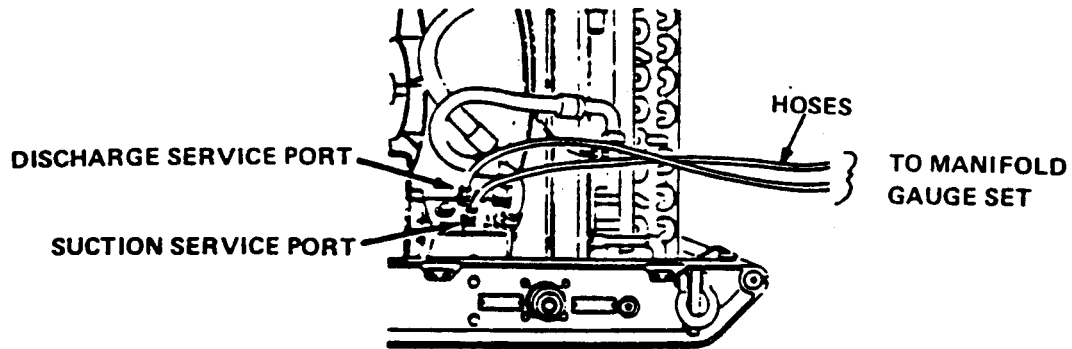
**DISCHARGE**

1. Remove caps from two service ports on compressor.
2. Close four service manifold hand valves.
3. Connect service manifold discharge hose to D (discharge) service port.
4. Connect service manifold suction hose to S (suction) service port.

WARNING

Death or serious injury may result if personnel fail to observe safety precautions. Use great care to avoid contact with liquid refrigerant or refrigerant gas discharging under pressure. Sudden and irreversible tissue damage can result from freezing. Wear thermal protective gloves and a face protector or goggles in any situation where skin-eye contact is possible.

5-3. REFRIGERANT SYSTEM SERVICE -DISCHARGE (CONT)

NOTE

In accordance with Environmental Protection Agency regulations refrigerants cannot be discharged into the atmosphere. A refrigerant recovery & recycling unit must be used whenever discharging the refrigerant system.

Operation of the recovery/recycling unit must be by AUTHORIZED PERSONNEL ONLY

5. Connect and operate a recovery/recycling unit in accordance with the manufacturer's instructions.

5-4. REFRIGERATION SYSTEM SERVICE - PURGING.

DESCRIPTION

This task covers: Purging

INITIAL SETUP

Equipment
Condition

<u>Para</u>	<u>Condition Description</u>	<u>Tools</u>
2-8	Engine stopped.	Tool Kit, Service Refrigeration, item 5, Appendix B
4-15	Housing removed.	Nitrogen Regulator, item 8, Appendix B
5-3	System discharged.	

Materials/Parts:

Dry nitrogen, item 11, Appendix E

5-4. REFRIGERATION SYSTEM SERVICE - PURGING (CONT)

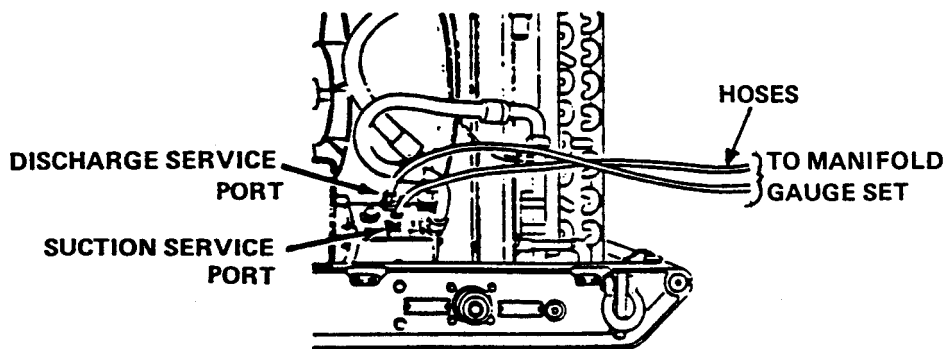
PURGING
WARNINGS

Nitrogen cylinders are pressurized containers. The pressure in the cylinder can exceed 2000 psi. A nitrogen pressure regulator should be used at all times when nitrogen is used for leak check or purge operations.

Nitrogen is an inert gas. However, it also presents danger as a suffocate and therefore, must also be discharged in a ventilated location.

NOTE

The refrigeration system must be purged with dry nitrogen, during any brazing/debrazing operation performed on any component. A flow of dry nitrogen at less than 1-2 cfm (0.028-0.057 m³/minute) should be continued during all heating operations to minimize internal oxidation and scaling.

After the system has been discharged using a service manifold as described in paragraph 5-3, proceed as follows:

1. See specific component removal/repair instructions.
2. Connect the high side charging hose from the service manifold to a nitrogen regulator and dry nitrogen tank.
3. The hose from the discharge service port to the service manifold must be connected.

5-4. REFRIGERATION SYSTEM SERVICE - PURGING (CONT)

4. The hose from the suction service port must be connected to the service manifold.
5. Open all hand valves on the service manifold.
6. Open the nitrogen cylinder valve and adjust the regulator so less than 1-2 cfm (0.028-0.057 m3/minute) of nitrogen flows through the refrigerant system.
7. Check discharge from hose attached to the suction service port to be sure that no oil is being forced out of the system.
8. Allow nitrogen to sweep through the system at less than 1-2 cfm (0.028-0.057 m3/minute) for a minimum of 5 minutes before starting any brazing/debrazing operation (see para 5-5). Then allow it to continue at the same rate until all brazing/debrazing operations are completed.
9. After brazing/debrazing operations are completed, allow nitrogen to flow for a minimum of 5 minutes. Close-all valves.
10. Disconnect the hose from the nitrogen tank.

5-5. REFRIGERATION SYSTEM SERVICE - BRAZING/DEBRAZING.

DESCRIPTION

This task covers: Debrazing, Brazing, and Inspection

INITIAL SETUP

Equipment
Condition

<u>Para</u>	<u>Condition Description</u>	<u>Tools</u>
2-8	Engine stopped.	Tool Kit, Service Refrigeration, item 5, Appendix B
4-15	Housing removed.	
5-4	Service manifold gauges attached and system purged.	

5-5. REFRIGERATION SYSTEM SERVICE - BRAZING/DEBRAZING (CONT)

Material/Parts:

Abrasive cloth, item 1, Appendix E
Brazing alloy, item 6, Appendix E
Flux brazing, item 12, Appendix E
Rags, item 23, Appendix E
Solder (silver), item 29, Appendix E

WARNING

Prevent contact of refrigerant gas with flame or hot surfaces. Heat causes the refrigerant to breakdown and form carbonyl chloride (phosgene), a highly poisonous and corrosive gas.

NOTE

All tubing in the refrigeration, water and fuel systems is made of copper with a finish that permits thorough cleaning. All interconnecting fittings, such as elbows, tees, etc., are also copper. The bodies of all connections on other components are brass. The refrigerant, water, and fuel systems can all be soldered using the same procedures. All joints, except those provided with flare fittings, are made by brazing according to MIL-B-7883, Type I, Grade B, except that radiographic examination is not required.

DEBRAZING

Debrazing joints for removal of refrigeration system components as follows:

WARNING

All refrigerant must be discharged from the system and the entire system must be purged with dry nitrogen before beginning any debrazing operation.

1. Determine which joints are to be debrazed. The limited work space inside the water chiller may make it more convenient to remove a part of the inter-connecting tubing with the component, rather than debrazing the joint itself.
2. Before debrazing a joint on a valve, disassemble the valve as completely as possible, then wrap all but the joint with a wet rag for a heat sink.

5-5. REFRIGERATION SYSTEM SERVICE - BRAZING/DEBRAZING (CONT)

3. protect insulation, wiring harness, sheet metal and other surrounding components with proper shields.
4. Be sure to do the work in a well ventilated area, and have dry nitrogen flowing through the refrigerant system (see paragraph 5-4) .
5. Apply enough heat uniformly around the joint to melt the filler alloy quickly. If heat is applied slowly, or only on one side, the, entire component or length of tubing will be heated and filler allow in adjacent joints may also be melted or weakened. Remove heat as soon as the joint separates.

BRAZING

1. Clean the mating surfaces and adjacent areas of all parts to be joined, remove all oil, grease, paint, dirt, scale, artificial oxide films, or any other foreign substances. Old filler alloy must be cleaned from debrazed joints before reassembly as best as possible. Heat each piece of the joint until the filler alloy is melted and then wipe it away with a dry rag. Use abrasive cloth and tubing wire brushes to clean the outside and inside joints respectively. Be sure no filler alloy or other debris is left inside any tubing, fitting or component.
2. Remove burrs to permit proper fitting of parts and flow of filler material. Unless otherwise specified, the clearance shall not exceed 0.006 inch (.15 mm).

NOTE

Grade IV or VI brazing alloy and Type B flux, as specified in MIL-B-7883, must be used for all copper to copper joints and all copper to brass joints. Grade III brazing alloy may be substituted for Grade IV or VI for copper to copper joints.

3. Use the following as a guide for brazing:
 - a. To prepare a joint on a valve for brazing, disassemble the valve as completely as possible. Then wrap all but the joint with a wet rag for a heat sink. Place tubing and/or components in water chiller in assembled position.
 - b. Ensure that the unit is being purged with nitrogen per paragraph 5-4.

5-5. REFRIGERATION SYSTEM SERVICE - BRAZING/DEBRAZING (CONT)

- c. Parts shall be preheated with a neutral or slightly reduced flame to bring the entire joint uniformly to the liquid temperature of the filler metal. Use only as much heat as needed to provide a satisfactory joint. Avoid localized overheating. Keep moving the flame in small arcs or figure eights. Most of the heat should go to the joint where the filler material is to flow.
- d. Introduce filler material at the opposite side from the flame. Use capillary action to fill the joint while feeding the filler material. Do NOT use the flame to melt the filler material. If the filler material will not melt when brought in contact with the joint, then the joint is not clean or hot enough.
- e. Use a wet rag to wipe the joint clean of flux residue.

INSPECTION

Inspect completed joint for the following:

1. The contour of an outside filler joint shall be of a uniform radius with minimum excess filler material.
2. Examine joint for pinholes. A pinhole is a defect caused by gases being expelled. It appears as a small, round, smooth-surfaced pocket on the surface of the filler material. Do not permit pinholes in any joint.
3. Inspect for any residual flux on the surface of a brazed joint. Clean of necessary.
4. Brazing filler material in excess of that required for the joint is acceptable providing the excess filler metal does not interfere with the function of the completed assembly.
5. When possible, inspect inside the joint for filler material penetration. Filler must appear at all edges of a joint to prove proper flow through the joint. Lack of penetration shall be cause for rejection of the joint.

5-6. REFRIGERATION SYSTEM SERVICE - LEAK-TEST.

DESCRIPTION

This task covers: Leak-testing

INITIAL SETUP

Equipment
Condition

<u>Para</u>	<u>Condition Description</u>	<u>Tools</u>
2-8	Engine stopped.	Tool Kit, Service Refrigeration, item 5, Appendix B
4-15	Housing removed.	
5-8, Steps 1-3	System charged to 50 psig minimum if needed.	

Materials/Parts:

Dry nitrogen, item 11, Appendix E
Bubble, liquid type, item 7, Appendix E
R-12 Refrigerant, item 24, Appendix E

1. Attach nitrogen tank to manifold gauges.
2. Open valve and apply 300 psig to refrigerant system.

NOTE

Two leak detection methods are recommended depending upon the estimated size of the leak. Different techniques are used for detection. Under certain conditions a large leak may mask a smaller leak and both techniques may be required. The larger leak is searched for first. Regardless of the size of the leak, the system must now be pressurized with refrigerant vapor, to the pressure of the refrigerant tank, using the charging manifold described previously. The pressure obtained will be the vapor pressure of R-12 and a function of the ambient temperature, probably in the order of 50-140 psig. Turn off the valve on the service manifold.

3. To detect large leak start with the liquid bubble type leak detector, and apply moderate quantities at each SAE fitting, tubing or hose connection. Leaks greater than 0.04 cc per hour will appear as a series of bubbles.

5-6. REFRIGERATION SYSTEM SERVICE - LEAK-TEST (CONT)

4. When the test area is free of residual refrigerant, warm up the electronic leak detector. Then calibrate it according to the instruction manual.

NOTE

This instrument is extremely sensitive, and is used to detect SMALL leaks. Exposing the probe to heavy refrigerant concentrations will cause the sensing element to "Hang-up", requiring rejuvenation by operating for a time in an atmosphere known to be free of refrigerant. The life of the catalytic element will be significantly shortened.

5. Move the probe slowly over possible leak points.
6. If the leak detector identifies refrigerant in the area before a specific point of sensing can be reached, either the ventilating time was too short or there is still a significant leak. Recheck area with liquid bubble detector, and/or ventilate area more thoroughly.

5-7. REFRIGERATION SYSTEM SERVICE - EVACUATION.

DESCRIPTION

This task covers: Evacuation

INITIAL SETUP

Equipment Condition

<u>Para</u>	<u>Condition Description</u>	<u>Tools</u>
2-8	Engine stopped.	Tool Kit, Service Refrigeration, item 5, Appendix B Vacuum Pump, item 7, Appendix B
4-15	Housing removed.	
5-3	Service manifold gauges attached and system discharged.	
		<u>Materials/Parts:</u>
5-24	New filter-dryer installed	Refrigerant, item 24, Appendix E

5-7. REFRIGERATION SYSTEM SERVICE - EVACUATION (CONT)

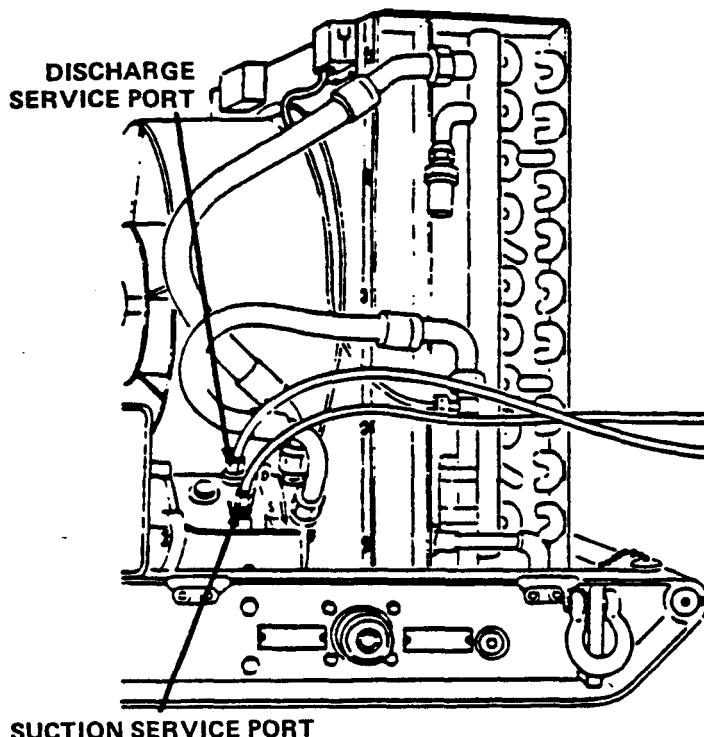

NOTES

Do not evacuate a leaking system. The vacuum created can pull air, moisture, and dirt into the system.

It is important that all non-condensables be removed prior to the final charge to avoid excessive head pressures and temperatures, and to use the full capacity of the system.

EVACUATION

1. Connect the hose from the service manifold to the vacuum pump. Use a larger diameter (3/8 in. ID) hose for greater efficiency between pump and manifold gauge set.
2. Arrange service manifold hoses so both a vacuum pump and an R-12 refrigerant tank can be accessed without breaking a vacuum. Open valve on refrigerant tank.

5-7. REFRIGERATION SYSTEM SERVICE - EVACUATION (CONT)

CAUTION

DO NOT operate compressor until directed to do so in the charging procedure. NEVER run the system without refrigerant.

3. Open both service manifold valves to show pressures on gauges.
4. Start vacuum Pump. Open evacuation manifold valve. Vacuum gauge will drop rapidly at first then more slowly but steadily approaching 29-30 inches Hg.
5. After a vacuum of 28 in. Hg. is achieved, close all service manifold valves.
6. Turn off vacuum pump.
7. Open charging manifold valve (hose from refrigerant tank) and suction service manifold valve and watch gauges. Stop flow when gauge readings reach 0 psi. Close charging manifold valve.
8. Start vacuum pump. Open evacuation manifold valve. Vacuum gauge will drop rapidly at first then more slowly but steadily approaching 29-30 inches Hg.
9. After a vacuum of 28 in. Hg. is achieved, close all service manifold valves.
10. Turn off vacuum pump.
11. Open charging manifold valve (hose from refrigerant tank) and suction service manifold valve and watch gauges. Stop flow when gauge readings reach 0 psi. Close charging manifold valve.
12. Start vacuum pump. Vacuum gauge will drop rapidly at first then more slowly but steadily approaching 29-30 inches Hg.
13. After a vacuum of 28 in. Hg. is achieved, close all service manifold valves.
14. Turn off vacuum pump.
15. Open refrigerant valve and suction service manifold valve and watch gauges. Stop flow when gauge readings reach 0 psi.
16. Start vacuum pump. Vacuum gauge will drop rapidly at first then more slowly but steadily approaching 29-30 inches Hg.

5-7. REFRIGERATION SYSTEM SERVICE - EVACUATION (CONT)

17. After a vacuum of 28 in. Hg. is achieved, close all service manifold valves.

NOTE

If the unit is to be charged at a later time, a holding charge of vapor to a pressure of 0-2 PSIG should be applied to prevent accidental contamination of the system by careless handling. Do not leave a system in a vacuum condition any longer than is necessary.

18. If the unit is to be charged, proceed immediately with the charging procedures (para 5-8).

19. Charge unit (para 5-8).

5-8. REFRIGERATION SYSTEM SERVICE - CHARGING.

DESCRIPTION

This task covers: Charging

INITIAL SETUP

<u>Equipment Condition Para</u>	<u>Condition Description</u>	<u>Tools</u>
2-8	Engine stopped.	Tool Kit, Service Refrigeration, item 5, Appendix B
4-15	Housing removed.	
5-7	Service manifold gauges attached and system evacuated.	

Materials/Parts:

Refrigerant R-12, item 24, Appendix E

5-8. REFRIGERATION SYSTEM SERVICE - CHARGING (CONT)

CHARGING

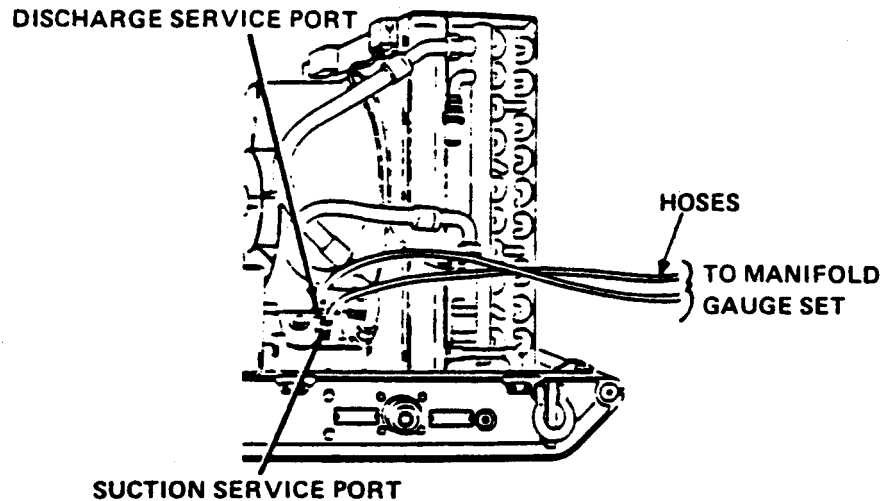
**NOTE**

The system must be evacuated before charging. Use only refrigerant R- 12 to charge the unit. If available, use recycled refrigerant.

1. If the service manifold is not still attached from the evacuation procedures attach it now.
2. Place refrigerant tank on a scale.
3. Open refrigerant tank valve.
4. With refrigerant tank on the scale, record value.

CAUTION

Never introduce liquid refrigerant into the low pressure suction service port.

5. Open the charging manifold valve and discharge service manifold valve (red gauge). Allow refrigerant to enter until either the charged refrigerant cylinder weight has decreased by 3.75 lbs. (1.7 kg) or until system pressure is equalized.
6. Close the refrigerant tank valve and all manifold valves.
7. Start water chiller (para 2-8b).
8. If the 3.75 lbs. (1.7 kg) full charge was obtained, skip step 9. If the system pressure equalized prior to obtaining a full charge of 3.75 lbs (1.7 kg), proceed with the next step.

5-8. REFRIGERATION SYSTEM SERVICE - CHARGING (CONT)

9. With the water chiller running, open the refrigerant tank valve. Open charging manifold valve and discharge service valve. Monitor the scale as the water chiller compressor draws additional refrigerant gas into the system until the full 3.75 lbs. (1.7 kg) charge is obtained. Close the refrigerant tank valve and all manifold valves.
10. Continue running the water chiller for 15 minutes.
11. After 15 minutes, observe the liquid sight indicator (sight glass) on skid.
 - a. A green center means the refrigerant moisture content is acceptable.
 - b. A yellow center means there is too much moisture in the system. It must be discharged, evacuated and recharged.
 - c. If the sight glass is milky white or bubbly liquid it means the system has a low charge. If it cannot be determined why the system is low, repeat the evacuation process and recharge.
 - d. A clear, bubble-free liquid sight glass indicates the system is fully charged.
12. Shut down water chiller (para. 2-8d).
13. Remove refrigerant tank and service manifold.

5-9. REFRIGERATION SYSTEM OPERATIONAL PRESSURE TEST.

DESCRIPTION

This task covers: Evacuation

INITIAL SETUP

Equipment Condition	<u>Condition Description</u>	<u>Tools</u>
<u>Para</u>		
2-8	Engine stopped.	Tool Kit, Service Refrigeration, item 5, Appendix B
4-15	Housing removed.	
5-3	Service manifold gauges attached.	

5-9. REFRIGERATION SYSTEM OPERATIONAL PRESSURE TEST (CONT)

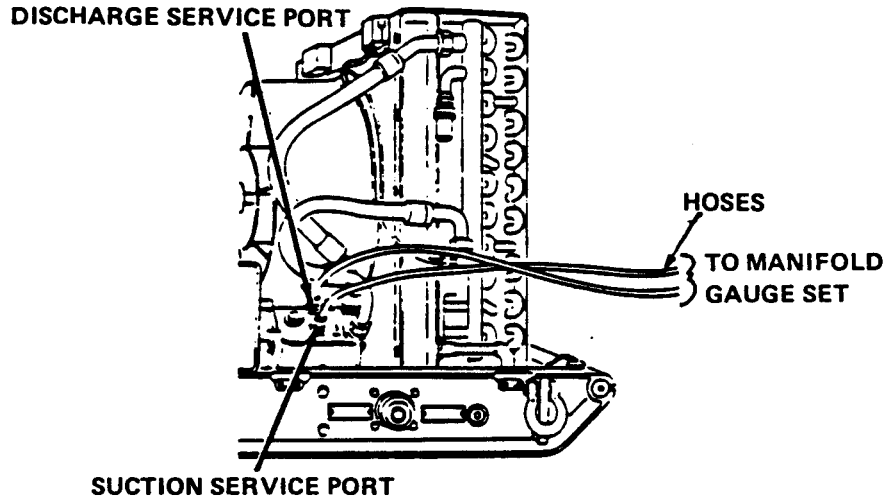

TEST

1. Open both service valves on manifold.
2. Start the water chiller (para 2-8b).
3. Note gauge readings. With the outdoor ambient temperatures of 125°F (52°C), the pressures should be in the following range:

Suction	61-71 psig.
Discharge	230-260 psig.
4. Close all valves and disconnect gauges.
5. Install service valve protective caps.
6. Shutdown water chiller (para 2-8d).

Section III. MAINTENANCE PROCEDURES

INDEX

	PARA
General	5-10
Cylinder Heads Replacement	5-11
Cylinder Block Assembly Repair	5-12
Compressor Suction Hose Replacement	5-13

Section III. MAINTENANCE PROCEDURES (CONT)

INDEX

	PARA
Compressor Discharge Hose Replacement	5-14
High Pressure Switch Replacement	5-15
Low Pressure Switch Replacement	5-16
Condenser Replacement	5-17
Pressure Relief Valve Replacement	5-18
Expansion Valve Replacement	5-19
Compressor Replacement	5-20
Centrifugal Clutch Replacement	5-21
Filter-Drier Replacement	5-22
Water System Leak Test	5-23
Evaporator Replacement	5-24
Relief Valve Replacement	5-25
Thermostatic Valve Replacement	5-26
Thermostatic Valve Repair	5-27
START-RUN Valve Assembly Replacement	5-28
Low Temperature Thermal Switch Replacement	5-29
Heat Exchanger	5-30
Skid Replacement	5-31
Trailer Mounting Kit Installation	5-32

5-10. GENERAL .

Scope. This section contains Direct Support maintenance instructions authorized by the Maintenance Allocation Chart (MAC) , Appendix B, and by the Source, Maintenance, and Recoverability (SMR) coded items to support the water chiller.

5-11. CYLINDER HEADS REPLACEMENT.

DESCRIPTION

This task covers: Removal, Inspection, and Installation

INITIAL SETUP

Equipment Condition	<u>Condition Description</u>	<u>Tools</u>
<u>Para</u>		
2-8	Engine stopped.	Tool Kit, General Mechanic's, item 1,
4-15	Housing removed.	Appendix B

5-11. CYLINDER HEADS REPLACEMENT (CONT)

Equipment
Condition

<u>Para</u>	<u>Condition Description</u>	<u>Tools</u>
4-30	Spark plugs removed.	Tap and Die Set (5136-01-119-0005), item 3, Appendix B

Materials/Parts:

Sealing compound, item 28,
Appendix E

Torque Wrench
(5120-00-247-2536),
item 3, Appendix B,
Supplement No. 2

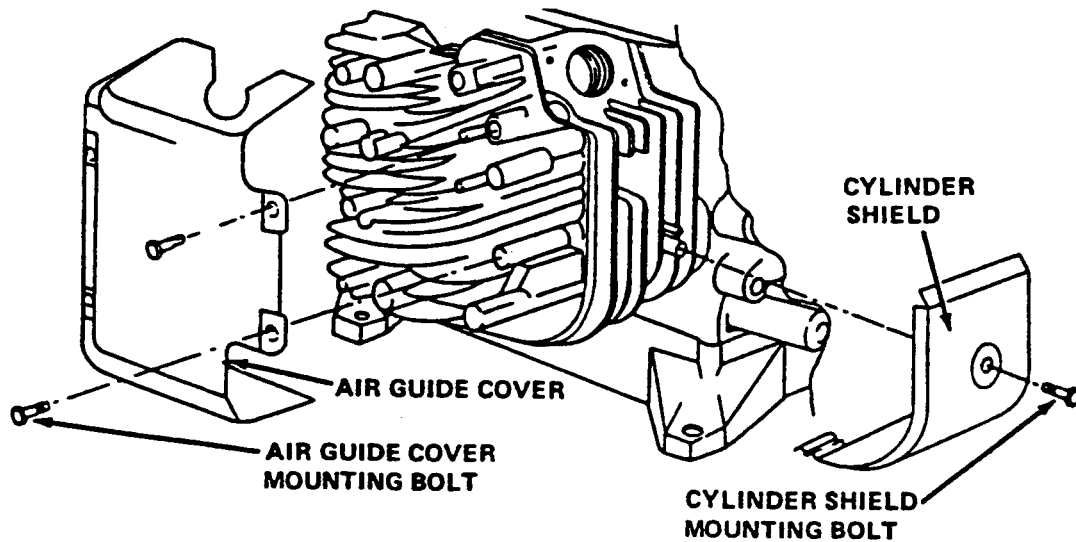

REMOVAL

NOTE

For right cylinder head remove starter panel bolts and lay aside.

1. Remove four air guide cover mounting bolts. Remove cylinder shield mounting bolt. Remove air guide cover and cylinder shield.
2. Remove spark plug (para 4-30).

5-11. CYLINDER HEADS REPLACEMENT (CONT)

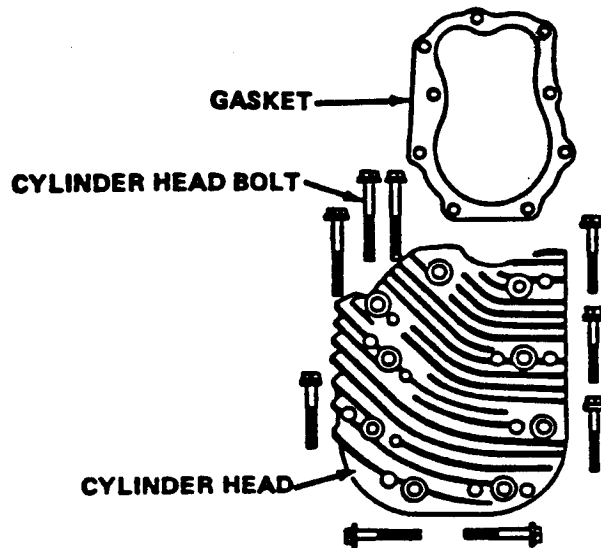

3. Remove nine cylinder head bolts. Remove cylinder head.
4. Remove all head gasket material from cylinder head and engine. Clean threads in cylinder block using tap.
5. Remove all carbon or foreign material from cylinder head and engine, being careful not to scratch surface.

INSPECTION

Inspect cylinder head for cracks from use or over tightening. Replace any cracked head.

INSTALLATION

1. Place new cylinder head gasket on cylinder head assembly.
2. Place cylinder head on engine.
3. Apply sealing compound to bolt threads. Install nine cylinder head bolts and hand-tighten.

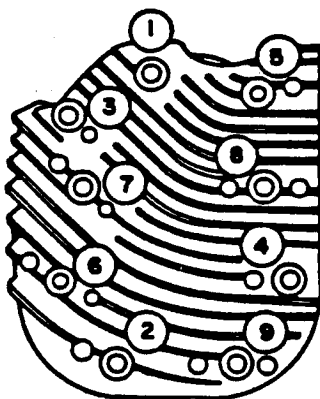

LEFT CYLINDER HEAD

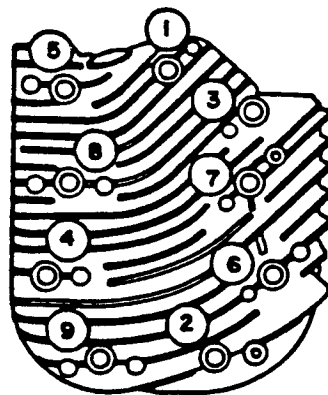

RIGHT CYLINDER HEAD

5-11. CYLINDER HEADS REPLACEMENT (CONT)

- Torque cylinder head bolts to 160 in. lb (18.1 Nm) following torque pattern above.

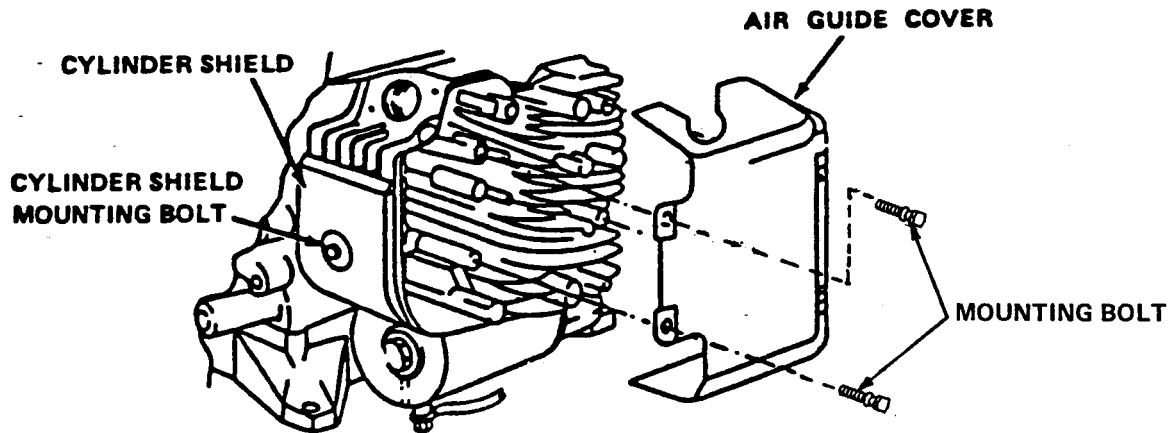

NOTE

For right cylinder head, attach starter panel when mounting air guide cover.

- Install air guide cover and cylinder shield. Install four air guide cover mounting bolts and cylinder shield mounting bolt.
- Install spark plug (para 4-30).

5-12. CYLINDER BLOCK ASSEMBLY REPAIR.

DESCRIPTION

This task covers: Disassembly and Assembly

INITIAL SETUP

Tools

Tool Kit, General Mechanic's, item 1, Appendix B

Personnel Required:

Two to lift engine.

Equipment Condition

Para Condition Description

2-8 Engine stopped.

Equipment Condition

Para Condition Description

5-11 Cylinder head assemblies removed.

5-12. CYLINDER BLOCK ASSEMBLY REPAIR (CONT)

Equipment Condition Para	Condition Description	Equipment Condition Para	Condition Description
4-15	Housing removed.	4-33	Starter removed.
4-25	Engine assembly removed.	4-31	Armature group removed.
4-22	Fan assembly removed.	4-34	Flywheel and ring gear assembly removed.
4-23	Centrifugal clutch assembly removed.	4-24	Exhaust system removed.
4-32	Dipstick and tube assembly removed.	4-45	Breather assemblies removed.
4-27	Carburetor and intake manifold removed.	4-28	Governor assembly removed.

Materials/Parts:
 Lockwasher MS35338-141

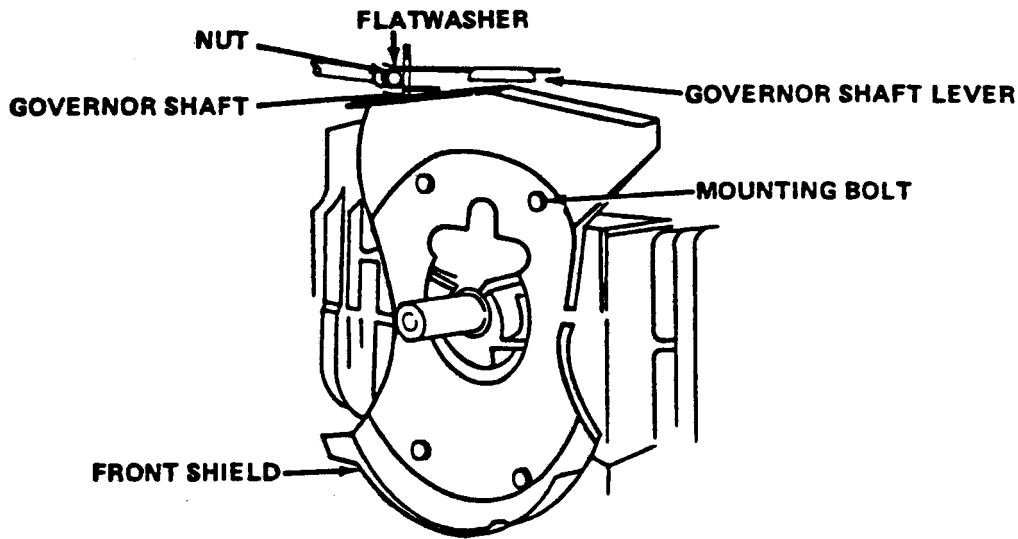

DISASSEMBLY

1. Loosen governor shaft lever nut and flatwasher.
2. Remove governor shaft lever.
3. Remove four front shield mounting bolts and lockwashers. Remove front shield.

5-12. CYLINDER BLOCK ASSEMBLY REPAIR (CONT)

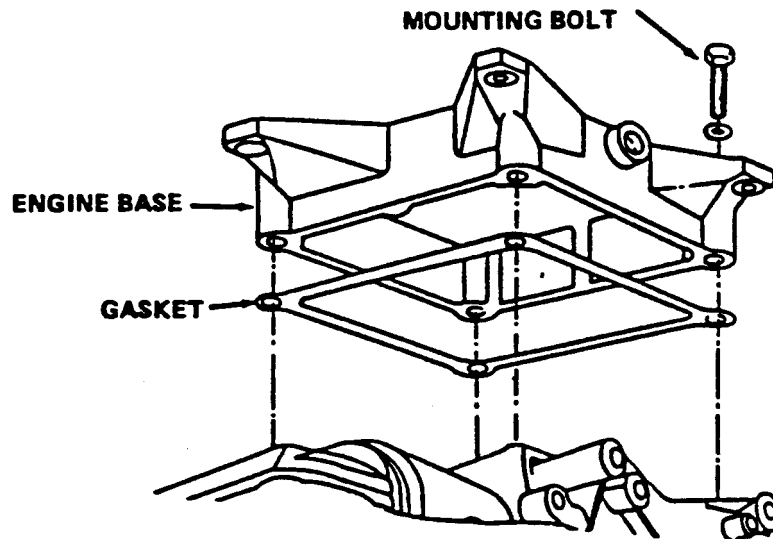

WARNING

Due to weight of equipment, two persons required for next step to prevent injury and damage to equipment.

4. Turn engine assembly upside down.
5. Remove four engine base mounting bolts and four lockwashers. Remove engine base. Remove gasket.

ASSEMBLY

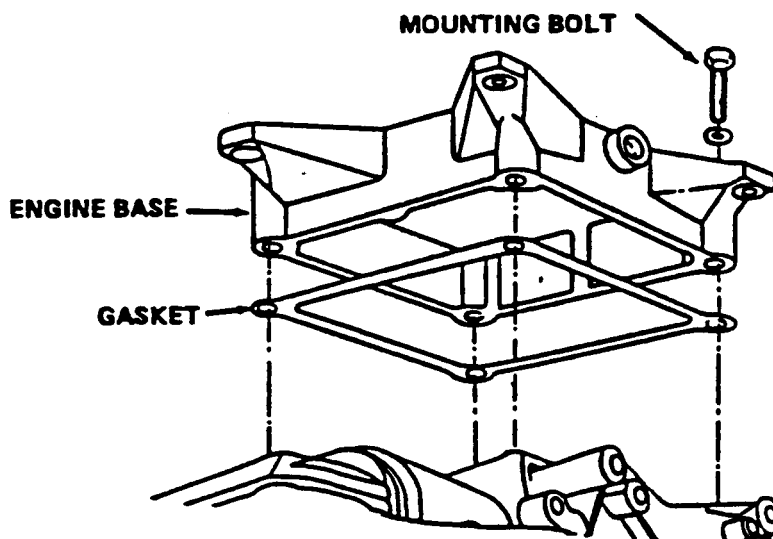

1. Install engine base and gasket on cylinder block assembly. Install four engine base mounting bolts and four lockwashers.

5-12. CYLINDER BLOCK ASSEMBLY REPAIR (CONT)

WARNING

Due to weight of equipment, two persons required for next step to prevent injury and damage to equipment.

2. Turn engine assembly rightside up.
3. Install governor assembly (para 4-28).

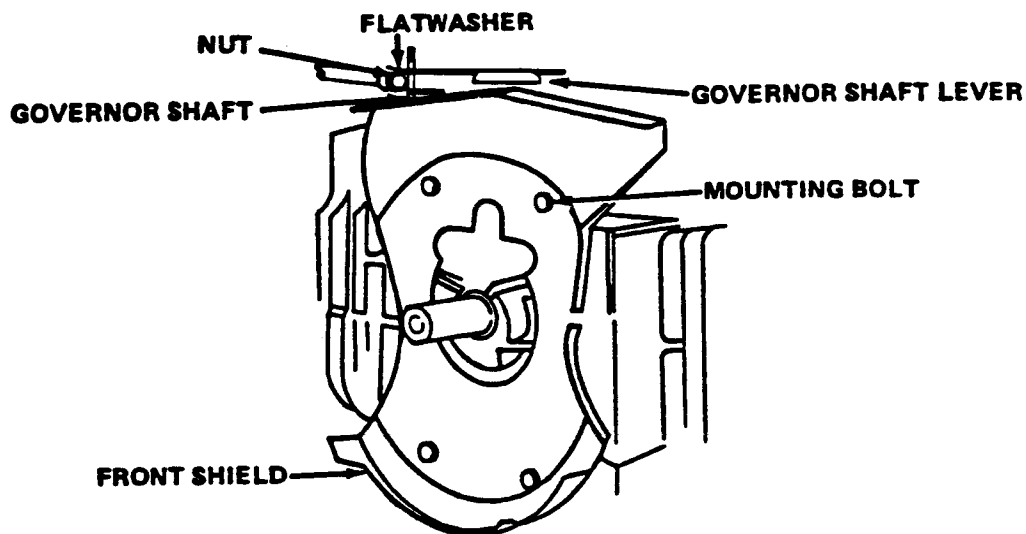

4. Install front shield. Install four front shield mounting bolts.
5. Install exhaust manifold assembly (para 4-24).
6. Install starter (para 4-33).
7. Install flywheel and ring gear assembly (para 4-34). DO NOT install blower housing.
8. Install armature group (para 4-31). DO NOT install blower housing.
9. Install breather assemblies (para 4-45).
10. Install cylinder head assemblies (para 5-11).
11. Install carburetor and intake manifold assembly (para 4-27).
12. Install dipstick and tube assembly (para 4-32).
13. Install centrifugal clutch assembly (para 4-23).
14. Install fan assembly (para 4-22).
15. Install engine assembly (para 4-25).

5-13. COMPRESSOR SUCTION HOSE REPLACEMENT.

DESCRIPTION

This task covers: Removal and Installation

INITIAL SETUP

Equipment
Condition

<u>Para</u>	<u>Condition Description</u>	<u>Tools</u>
2-8	Engine stopped.	Tool Kit, Service Refrigeration, item 5, Appendix B Wrench, open end, 1 inch, item 3, Appendix B
4-15	Housing removed.	
5-3	Refrigeration system discharged.	

Materials/Parts:

Strap, tiedown MS3367-1-9
Filter-drier 13226E1786

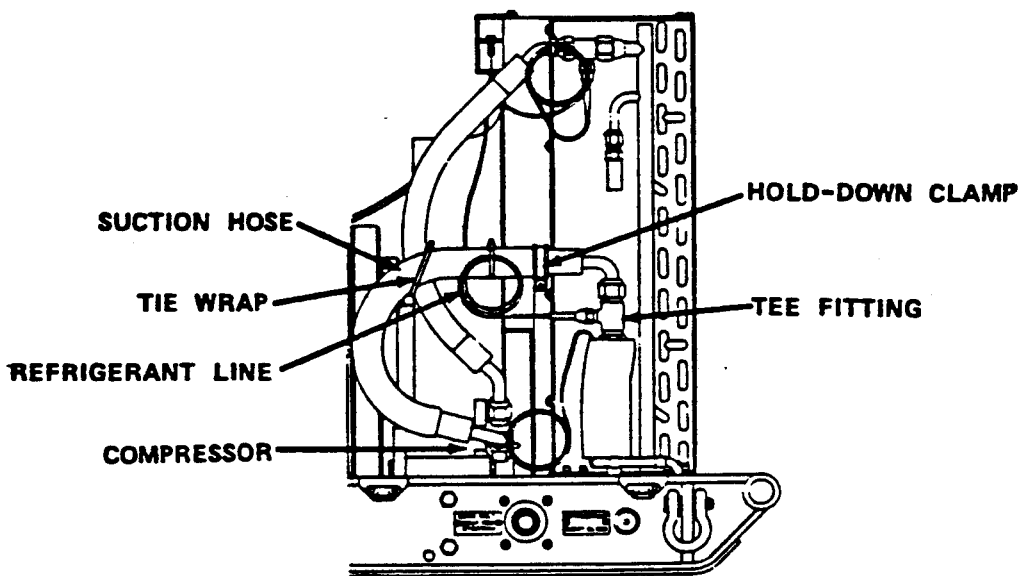

REMOVAL

1. Cut tie wraps from hose.

5-13 . COMPRESSOR SUCTION HOSE REPLACEMENT (CONT)

2. Remove screw, flatwasher, and hold-down clamp.
3. Remove hose fitting from compressor.
4. Remove hose fitting from tee fitting. Remove hose.

INSTALLATION

1. Install hose fitting on tee fitting.
2. Install hose fitting on compressor suction port.
3. Install screw, flatwasher, and hold-down clamp.
4. Install tie wraps around lines and hose.
5. Replace filter-drier before evacuating system (para 5-22).
6. Leak-test system (para 5-6).
7. Evacuate system (para 5-7).
8. Charge system (para 5-8).

5-14. COMPRESSOR DISCHARGE HOSE REPLACEMENT.

DESCRIPTION

This task covers: Removal and Installation

INITIAL SETUP

Equipment Condition	<u>Condition Description</u>	<u>Tools</u>
<u>Para</u>		
2-8	Engine stopped.	Tool Kit, Service Refrigeration, item 5, Appendix B
4-15	Housing removed.	
5-3	Refrigeration system discharged.	

Materials/Parts:

- Strap, tiedown MS3367-1-9
- Filter-drier 13226E1786

5-14. COMPRESSOR DISCHARGE HOSE REPLACEMENT (CONT)

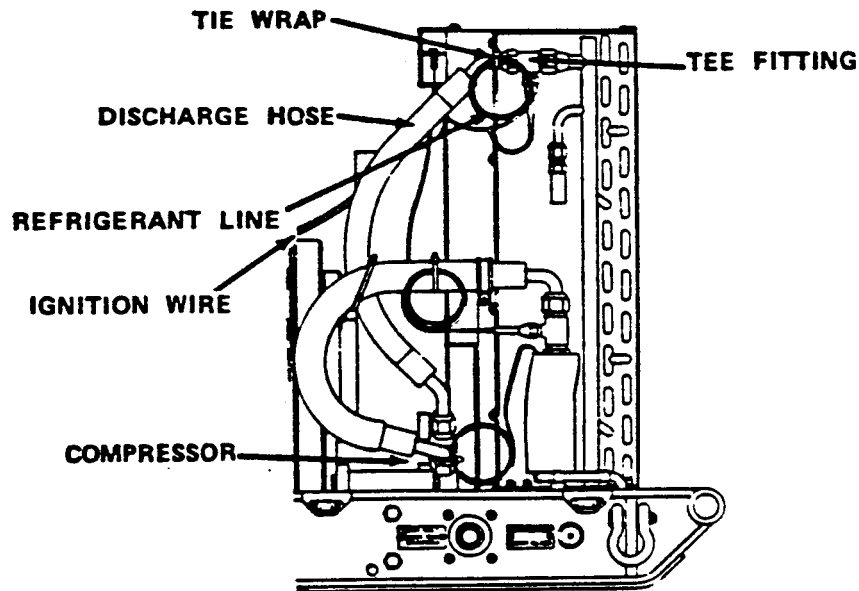
REMOVAL

1. Cut tie wraps as needed to free refrigerant line.
2. Remove hose fitting from compressor.
3. Remove hose fitting from tee fitting.

INSTALLATION

1. Install hose fitting at tee fitting.
2. Install hose fitting at compressor discharge service port.
3. Install tie warps around hose and refrigerant line.
4. Replace filter-drier before evacuating system (para 5-22).
5. Leak-test system (para 5-6).
6. Evaucate system (para 5-7).
7. Charge system (para 5-8).

5-15. HIGH PRESSURE SWITCH REPLACEMENT.

DESCRIPTION

This task covers: Removal and Installation

INITIAL SETUP

Equipment
Condition

<u>Para</u>	<u>Condition Description</u>	<u>Tools</u>
2-8	Engine stopped.	Tool Kit, Service Refrigeration, item 5, Appendix B
4-15	Housing removed.	
5-3	Refrigeration system discharged.	<u>Materials/Parts:</u> Tags, item 32, Appendix E Filter-drier 13226E1786 Strap, tiedown MS3367-1-9

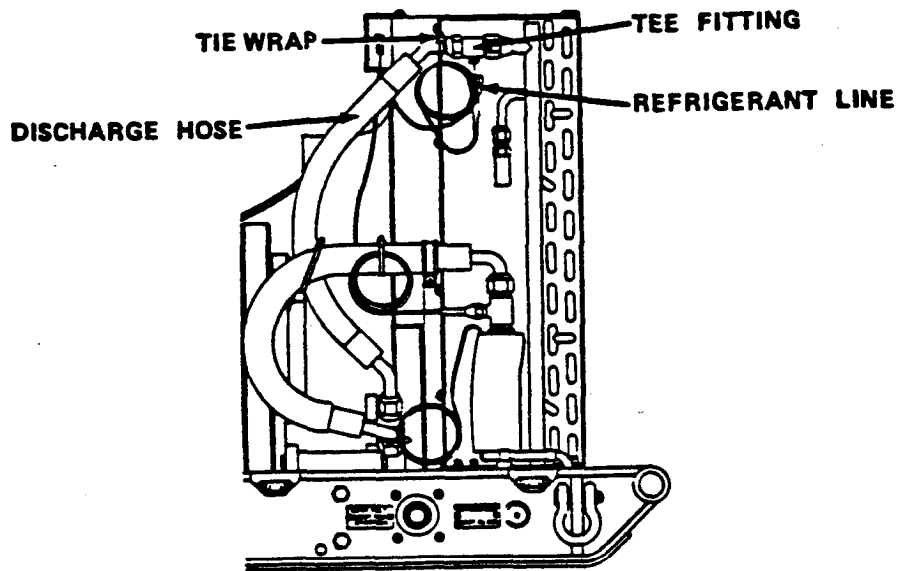

REMOVAL

1. Cut tie wrap from discharge hose of compressor.
2. Remove refrigerant line at tee fitting.

5-15. HIGH PRESSURE SWITCH REPLACEMENT (CONT)

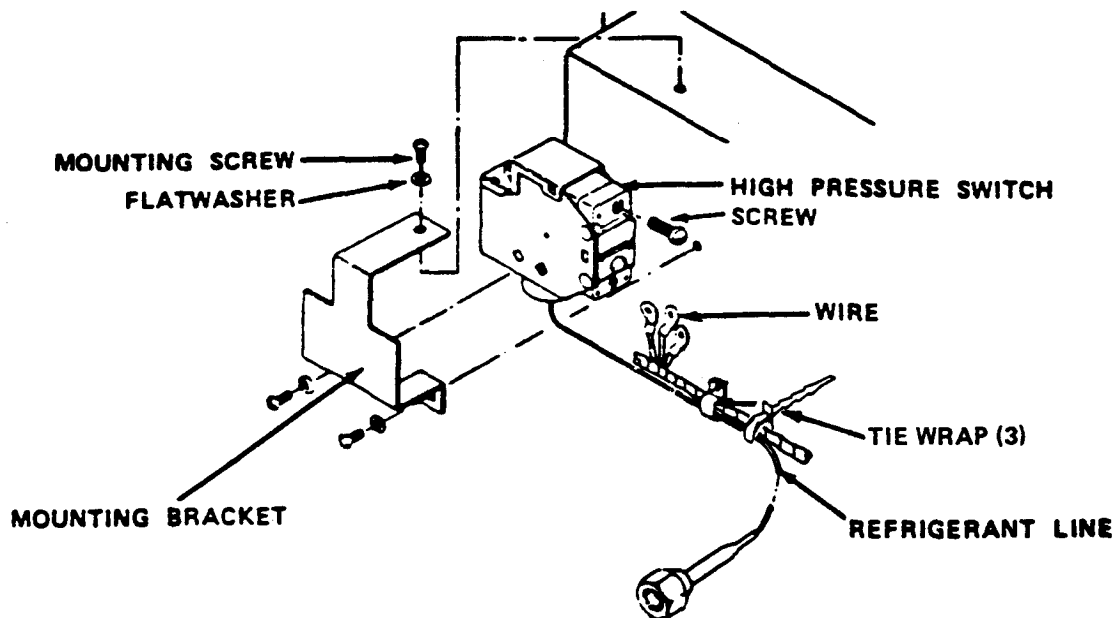

- Cut three tie wraps attaching refrigerant line to wiring harness.

WARNING

To prevent electric shock, make sure power is disconnected from 12 VOLT INPUT FOR STARTING connection before performing this procedure.

- Tag three wires from switch. Remove two screws and three wires.
- Remove three bracket mounting screws and three flatwashers.
- Remove mounting bracket from switch.
- Remove high pressure switch and refrigerant line.

INSTALLATION

- Install high pressure switch and refrigerant line in mounting bracket.
- Install mounting bracket, three mounting screws, and three flatwashers.

5-15. HIGH PRESSURE SWITCH REPLACEMENT (CONT)

3. Connect three wires to switch. Install two screws. Remove tags.

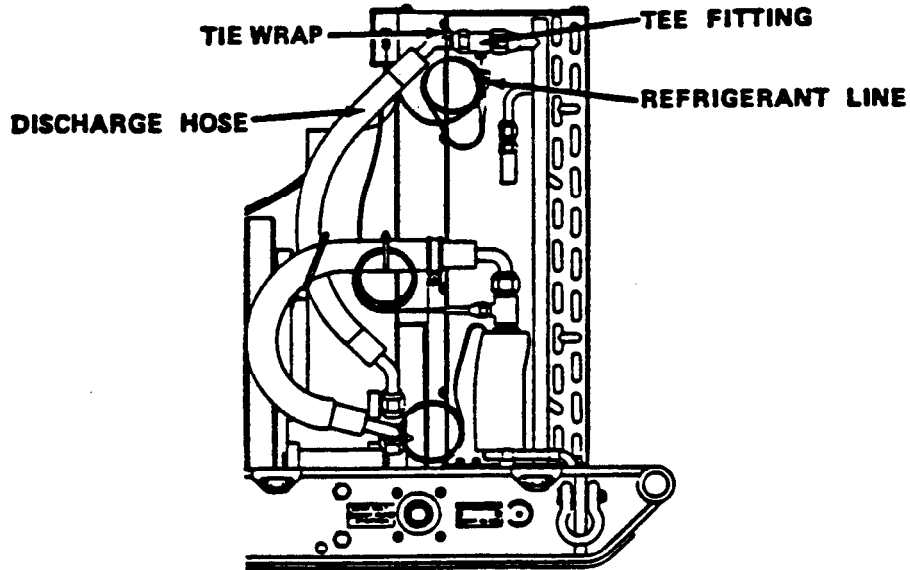

4. Tie wrap refrigerant line to wire harness.
5. Attach refrigerant line fitting to tee fitting.
6. Install tie wrap around refrigerant line and discharge hose.
7. Replace filter-drier before evacuating system (para 5-24).
8. Leak-test system (para 5-6).
9. Evacuate system (para 5-7).
10. Charge system (para 5-8).

5-16. LOW PRESSURE SWITCH REPLACEMENT.

DESCRIPTION

This task covers: Removal and Installation

INITIAL SETUP

Equipment
Condition

<u>Para</u>	<u>Condition Description</u>	<u>Tools</u>
2-8	Engine stopped.	Tool Kit, Service Refrigeration, item 5, Appendix B
4-15	Housing removed.	
5-3	Refrigeration system discharged.	<u>Materials/Parts:</u> Strap, tiedown MS3367-1-9 Filter-drier 13226E1786

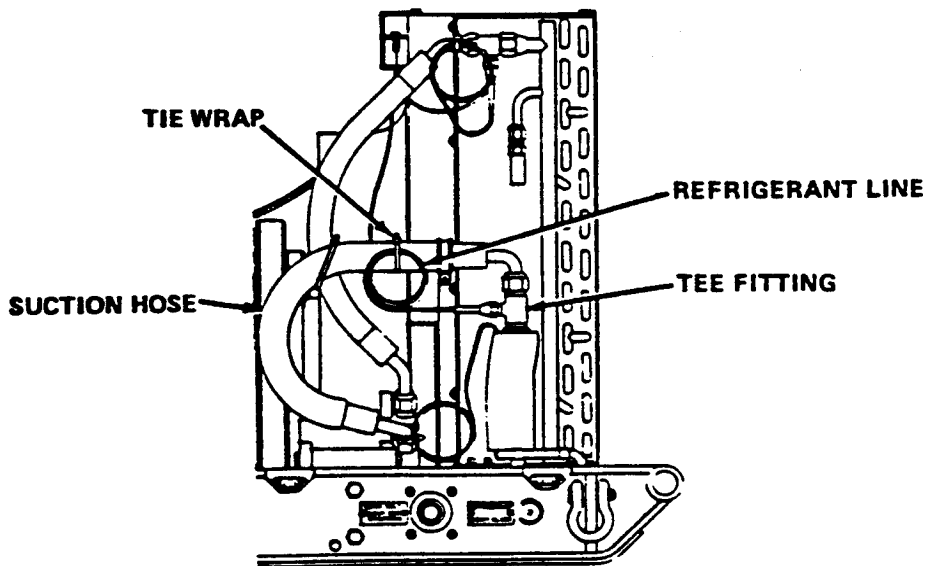

REMOVAL

1. Cut tie wrap from suction hose of compressor.
2. Remove refrigerant line from tee fitting.

5-16. LOW PRESSURE SWITCH REPLACEMENT (CONT)

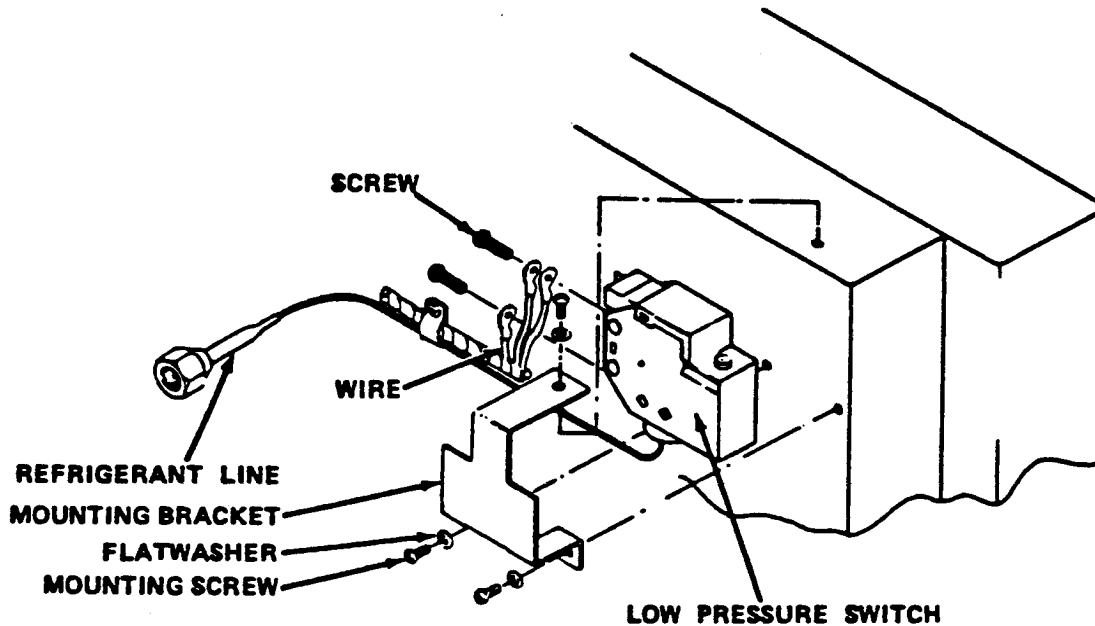

3. Tag three wires from switch. Remove two screws and three wires.
4. Remove three bracket mounting screws and three flatwashers.
5. Remove mounting bracket from switch.
6. Remove low pressure switch and refrigerant line.

INSTALLATION

1. Install, new low pressure switch and refrigerant line in mounting bracket.
2. Install mounting bracket, three mounting screws, and three flatwashers.
3. Connect three wires to switch. Install two screws. Remove tags.
4. Connect refrigerant line fitting to tee fitting.
5. Install new tie wrap around refrigerant line and suction hose.
6. Replace filter-drier before evacuating system (para 5-22).
7. Leak-test system (para 5-6).

5-16. LOW PRESSURE SWITCH REPLACEMENT (CONT)

- 8. Evacuate system (para 5-7).
- 9. Charge system (para 5-8).

5-17. CONDENSER REPLACEMENT.

DESCRIPTION

This task covers: Removal and Installation

INITIAL SETUP

<u>Equipment Condition Para</u>	<u>Condition Description</u>	<u>Tools</u>
2-8	Engine stopped.	Tool Kit, Service Refrigeration, item 5, Appendix B
4-15	Housing removed.	
5-3	Refrigeration system discharged.	<u>Materials/Parts:</u>
5-18	Pressure relief valve removed.	Brazing alloy, item 6, Appendix E Filter-drier 13226E1786 Lockwasher MS35338-139 Strap, tie down MS3367-1-9

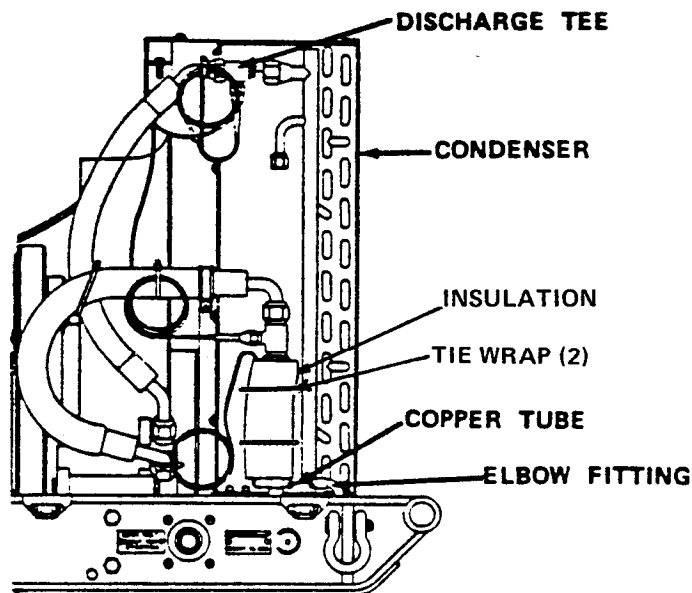

5-17 . CONDENSER REPLACEMENT (CONT)

REMOVE

1. Remove discharge tee from condenser fitting.
2. Remove tie wraps and insulation.
3. Debraze copper tube at elbow fitting nearest condenser coil (para 5-4) .

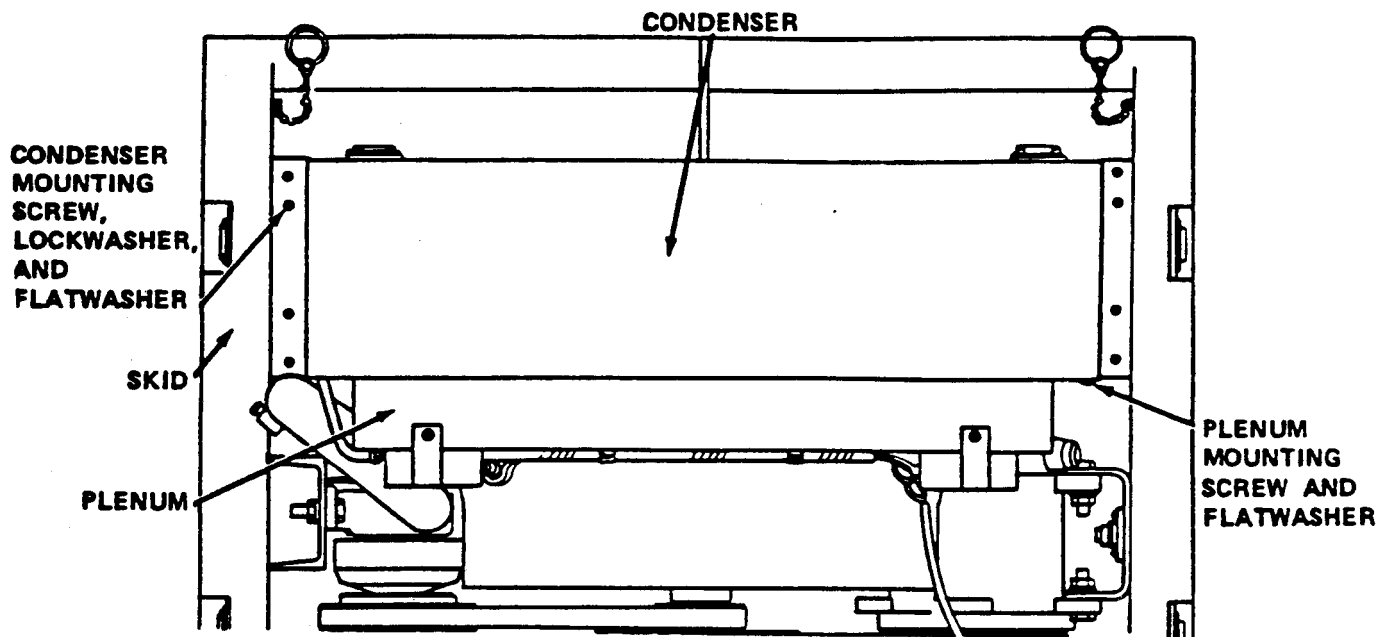

4. Remove eight plenum mounting screws and flatwashers.
5. Remove eight condenser mounting screws, lockwashers, and flatwashers.
6. Lift condenser from skid base.

INSTALLATION

1. Install new condenser on skid base and align mounting holes.
2. Install eight condenser mounting screws, lockwashers, and flatwashers.
3. Install eight plenum mounting screws and flatwashers.

5-17. CONDENSER REPLACEMENT (CONT)

4. Braze copper tube onto elbow fitting (para 5-4).
5. Tie wrap insulation over sensing bulb.
6. Install discharge tee to condenser fitting.
7. Install pressure relief valve (para 5-18).
8. Replace filter-drier before evacuating system (para 5-22).
9. Leak-test system (para 5-6).
10. Evacuate system (para 5-7).
11. Charge system (para 5-8).

5-18. PRESSURE RELIEF VALVE REPLACEMENT.

DESCRIPTION

This task covers: Removal and Installation

INITIAL SETUP

Equipment
Condition

<u>Para</u>	<u>Condition Description</u>	<u>Tools</u>
2-8	Engine stopped.	Tool Kit, Service Refrigeration, item 5, Appendix B
4-15	Housing removed.	
5-3	Refrigeration system discharged.	<u>Materials/Parts:</u> Filter-drier 13226E1786

5-18. PRESSURE RELIEF VALVE REPLACEMENT (CONT)

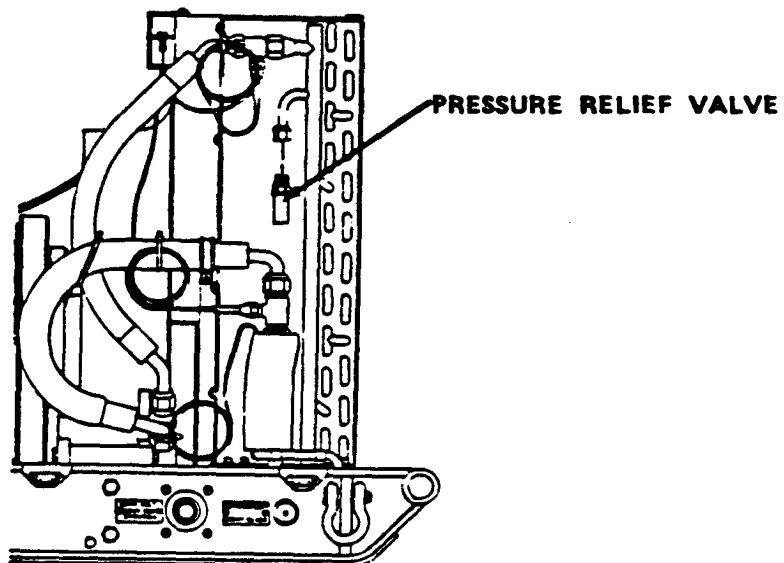

REMOVAL

Remove pressure relief valve.

INSTALLATION

1. Install new pressure relief valve.
2. Replace filter-drier before evacuating system (para 5-22).
3. Leak-test system (para 5-6).
4. Evacuate system (para 5-7).
5. Charge system (para 5-8).

5-19. EXPANSION VALVE REPLACEMENT.

DESCRIPTION

This task covers: Testing, Removal and Installation

INITIAL SETUP

Equipment
Condition

<u>Para</u>	<u>Condition Description</u>	<u>Tools</u>
2-8	Engine stopped.	Tool Kit, Service Refrigeration, item 5, Appendix B Tap and Die Set (5136-01-119-0005) item 3, Appendix B
4-15	Housing removed.	
5-3	Refrigeration system discharged.	
4-1	Engine oil drained.	<u>Materials/Parts:</u> Sealant Compound, item 27, Appendix E

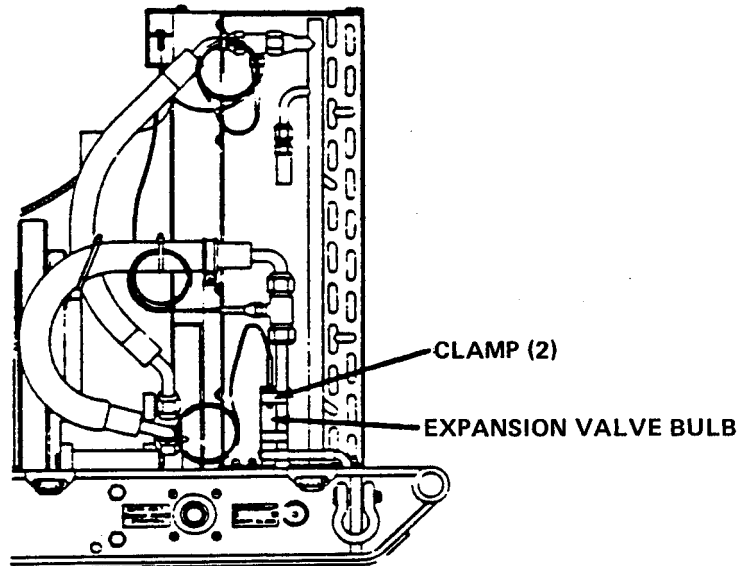

TESTING

1. Cut tie wraps and remove insulation covering expansion valve bulb being careful not to nick bulb or line.

5-19. EXPANSION VALVE REPLACEMENT (CONT)

2. Loosen expansion valve bulb clamps (2) and carefully slide clamps free of expansion valve bulb from suction line.

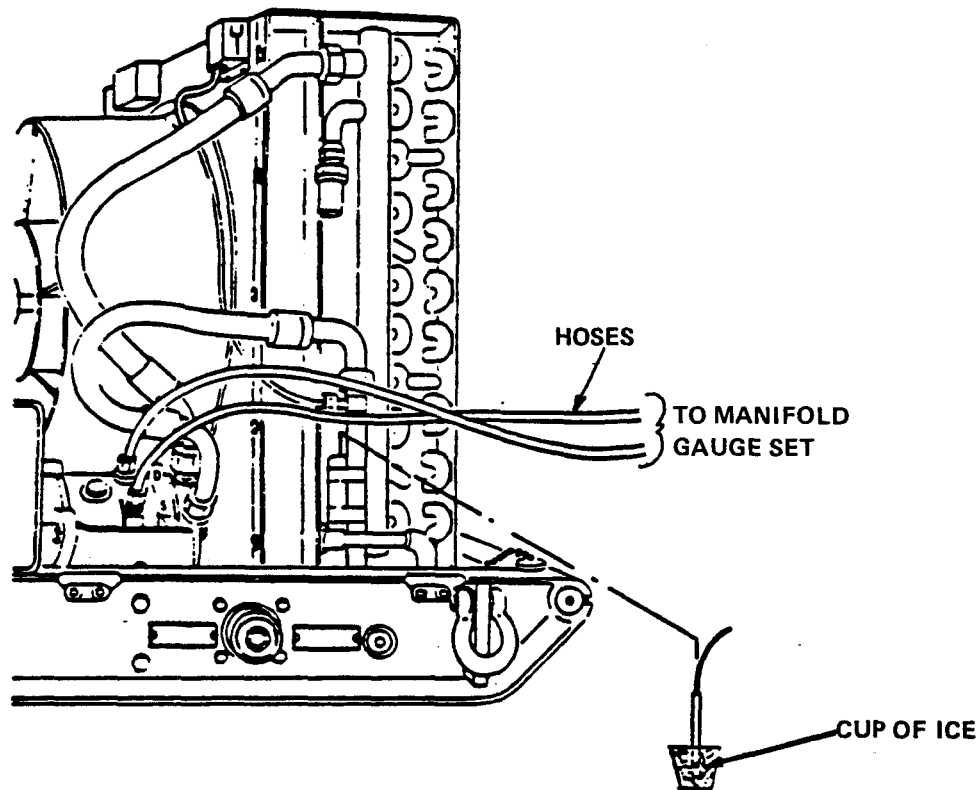

3. Install refrigeration charging manifold and manifold hoses (para 5-3, 1 thru 5).
4. Start engine (para 2-8b) and observe low pressure gauge.
5. Insert the expansion valve bulb in a cup of ice.

NOTE

Engine will automatically stop when refrigerant pressure drops below 24 psi (165 kN/m²).

6. Hold toggle switch S-3 in START position to prevent engine from stopping during test.

5-19. EXPANSION VALVE REPLACEMENT (CONT)

7. Again observe low pressure gauge. Pressure should reduce to about 30 psi (207 kN/m²). If pressure is not reduced to 30 psi or falls below 25 psi (172 kN/m²), the expansion valve is defective and should be replaced.
8. Stop engine, close all valves and disconnect gauges.
9. Install service valve protective caps.
10. Slide clamps upon expansion valve bulb and suction line.
11. Tighten screws in expansion valve bulb clamps, ensuring good contact along the entire length of the bulb.
12. Replace insulation surrounding expansion valve bulb with tie wraps.

REMOVAL

1. Drain engine oil (para 4-1).
2. Cut tie wraps and remove insulation from expansion valve bulb.
3. Loosen two expansion valve bulb clamps and carefully slide clamps free of expansion valve bulb.

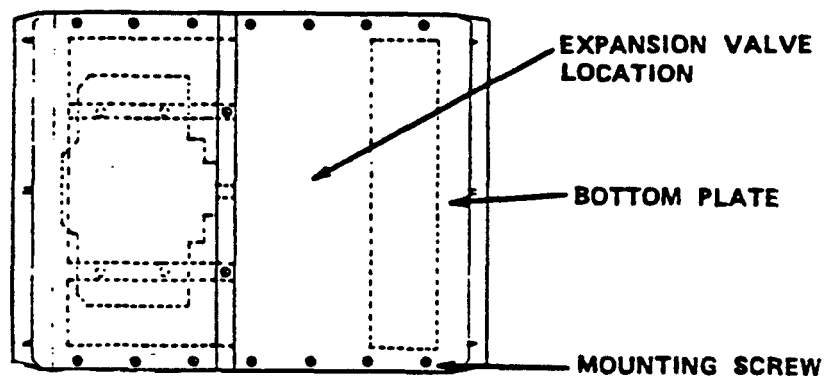

4. Set water chiller on its side.
5. Remove 16 bottom plate mounting screws. Remove bottom plate. Clean threads in skid base using tap.

5-19. EXPANSION VALVE REPLACEMENT (CONT)

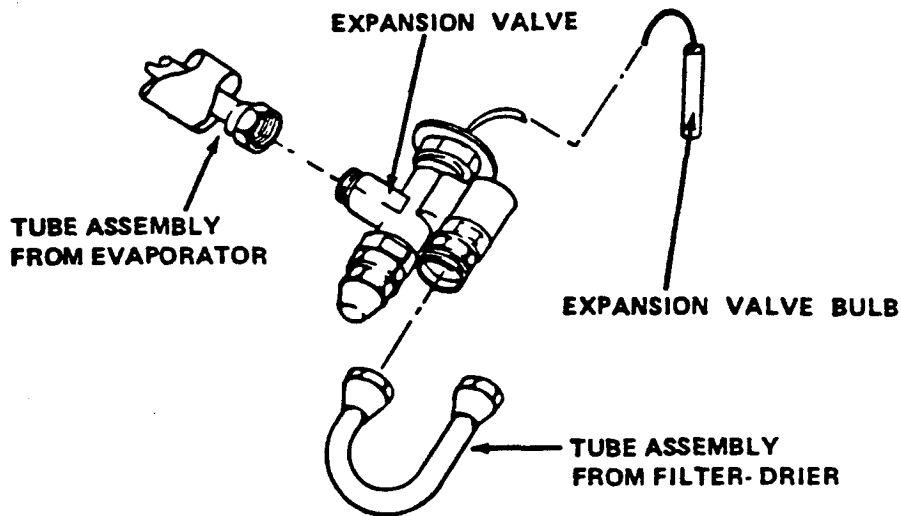

6. Remove tube assembly from expansion valve leading from filter-drier.
7. Remove tube assembly from expansion valve leading from evaporator.
8. Remove expansion valve and bulb assembly.

INSTALLATION

1. Install new expansion valve and route bulb to suction line.
2. Connect tube assembly at expansion valve leading from evaporator.
3. Connect tube assembly at expansion valve leading from filter-drier.
4. Replace filter-drier before evacuating system (para 5-22).

5-19. EXPANSION VALVE REPLACEMENT (CONT)

5. Leak-test system (para 5-6).
6. Install bottom plate with 16 bottom plate mounting screws using sealing compound.

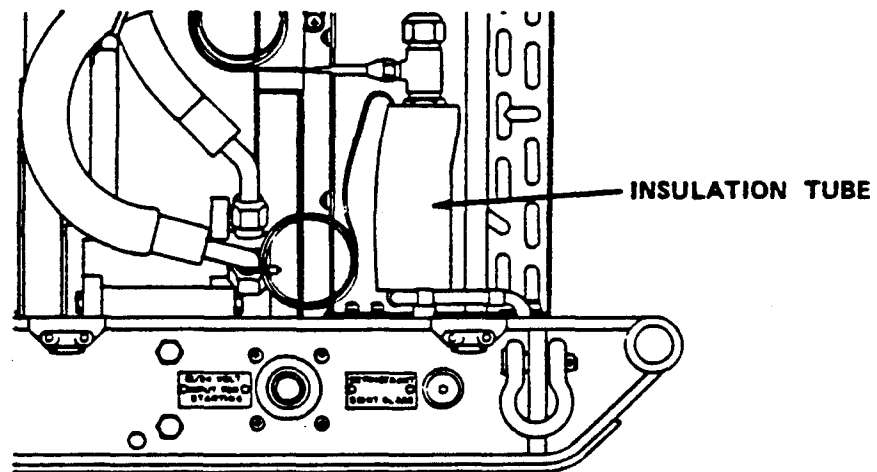

7. Set water chiller on skid base.
8. Slide clamps up on expansion valve bulb and suction line. Tighten screws in expansion valve bulb clamps, ensuring good contact along the entire length of the bulb.
9. Install insulation tube on bulb assembly with tie wraps.
10. Add engine oil (para 4-1).
11. Evacuate system (para 5-7).
12. Charge system (para 5-8).

5-20. COMPRESSOR REPLACEMENT.

DESCRIPTION

This task covers: Removal and Installation

5-20. COMPRESSOR REPLACEMENT (CONT)

INITIAL SETUP

<u>Equipment Condition Para</u>	<u>Condition Description</u>	<u>Tools</u>
2-8	Engine stopped.	Tool Kit, Service Refrigeration, item 5, Appendix B
4-15	Housing removed.	
4-21	Compressor drivebelt removed.	<u>Materials/Parts:</u>
5-3	Refrigeration system discharged.	Lockwasher MS35338-139 Lockwasher MS35338-141 Compressor oil, item 18, Appendix E
5-13	Compressor suction hose removed.	
5-14	Compressor discharge hose removed.	

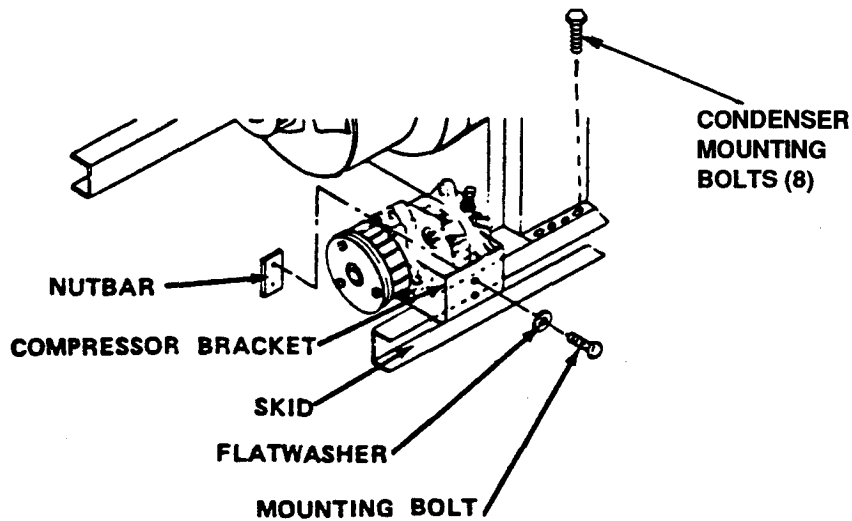

REMOVAL

1. Remove eight condenser mounting bolts, lockwashers and flatwashers.

5-20. COMPRESSOR REPLACEMENT (CONT)

2. Remove two compressor bracket mounting bolts, two flatwashers, and nutbar.
3. Lift compressor and bracket from skid base.

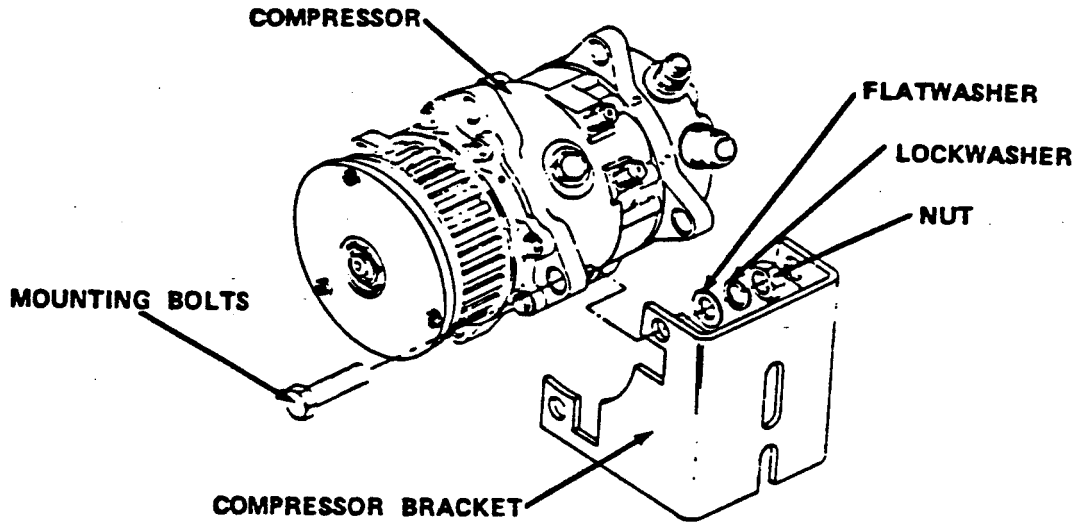

4. Remove four compressor mounting bolts, nuts, flatwashers, and lockwashers. Remove bracket.

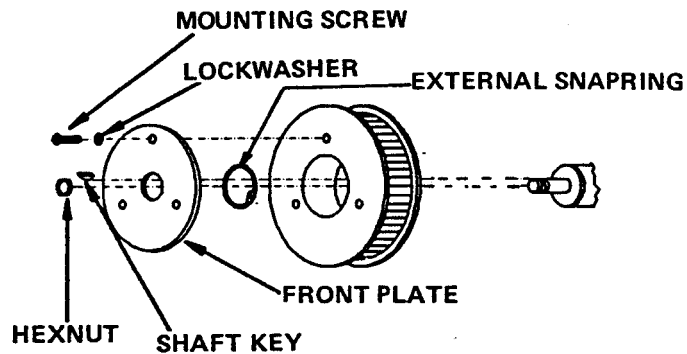

5. Remove locknut in center of front plate.

5-20. COMPRESSOR REPLACEMENT (CONT)

6. Remove three front plate mounting screws and three lockwashers. Remove front plate.
7. Remove shaft key.
8. Remove external snapring (smaller one).
9. Remove centrifugal clutch assembly from compressor.

INSTALLATION

1. Drain oil from new compressor. Add 5 oz (148 ml) of the oil back to new compressor.
2. Install centrifugal clutch and bearing assembly on compressor shaft. Make sure assembly is flush with compressor front housing hub .
3. Install external bearing snapring.
4. Install shaft key.
5. Install front plate in alignment with shaft key.
6. Loosely install three mounting screws and three lockwashers in front plate.
7. Install, locknut in center of front plate.
8. Tighten three front plate mounting screws.

5-20. COMPRESSOR REPLACEMENT (CONT)

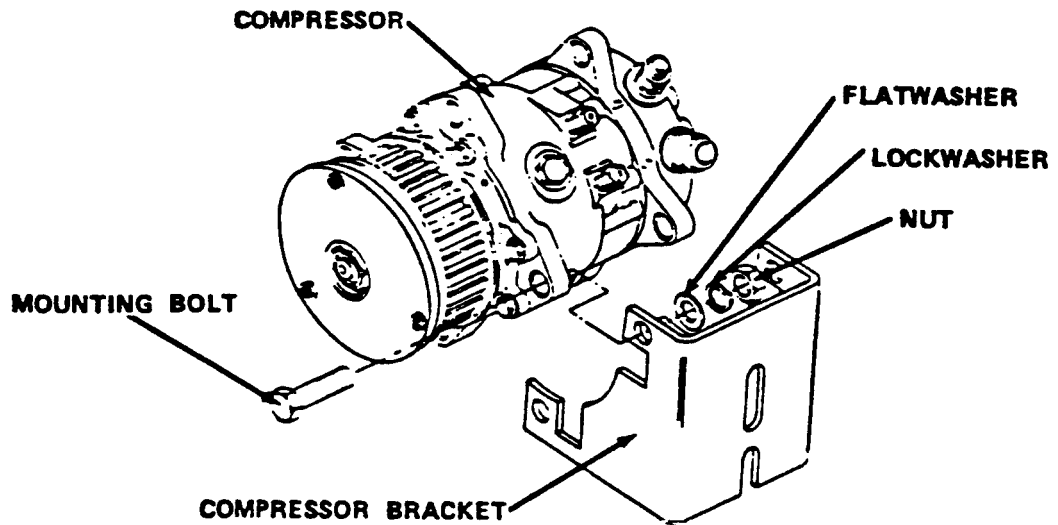

9. Install compressor on bracket. Install four compressor mounting bolts, flatwashers, lockwashers, and nuts.

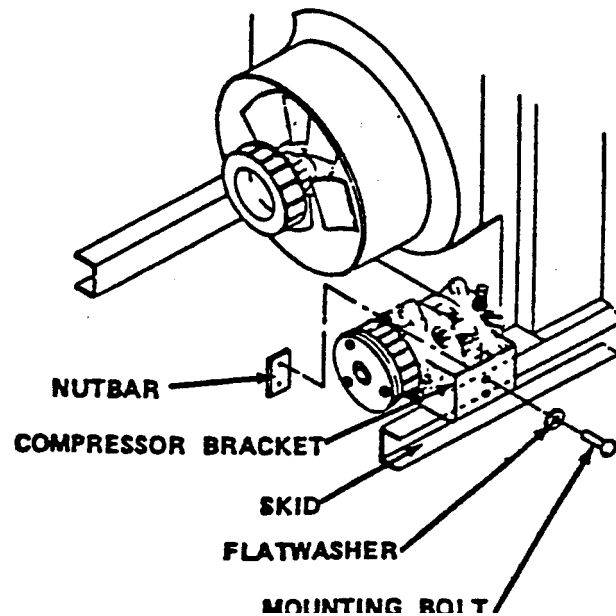

10. Install compressor and bracket on skid base.

5-20. COMPRESSOR REPLACEMENT (CONT)

11. Install two flatwashers, compressor bracket mounting bolts, and nutbar. Hand-tighten.
12. Install eight condenser mounting bolts.
13. Install compressor drivebelt and adjust (para 4-21).
14. Install suction hose on compressor (para 5-13).
15. Install discharge hose on compressor (para 5-14).
16. Replace filter-drier before evacuating system (para 5-22).
17. Leak-test system (para 5-6).
18. Evacuate system (para 5-7).
19. Charge system (para 5-8).

5-21. CENTRIFUGAL CLUTCH ASSEMBLY REPLACEMENT.

DESCRIPTION

This task covers: Removal and Installation

INITIAL SETUP

Equipment
Condition

<u>Para</u>	<u>Condition Description</u>	<u>Tools</u>
2-8	Engine stopped.	Tool Kit, Service Refrigeration, item 5, Appendix B
4-15	Housing removed.	
5-3	Service manifold gauges attached.	
5-20	Compressor removed.	

5-21. CENTRIFUGAL CLUTCH ASSEMBLY REPLACEMENT (CONT)

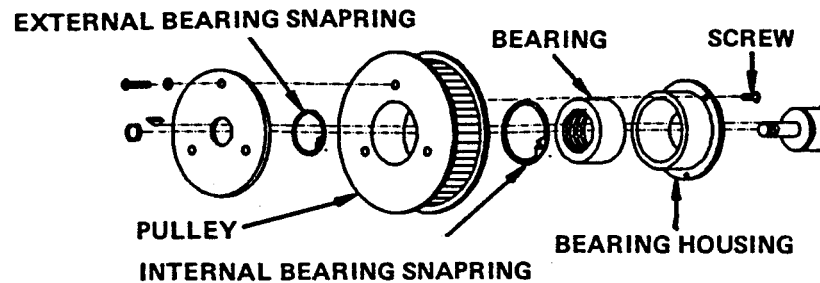
REMOVAL

1. Remove three screws holding bearing housing and internal snapping (larger one).
2. Remove housing from centrifugal clutch.
3. Remove bearing.

INSTALLATION

1. Place bearing in bearing housing. Install internal snapping in housing.
2. Install bearing and housing in centrifugal clutch assembly.
3. Retain bearing and housing with three screws.
4. Install compressor (para 5-20).

5-22. FILTER-DRIER REPLACEMENT.

DESCRIPTION

This task covers: Removal and Installation

INITIAL SETUP

<u>Equipment Condition Para</u>	<u>Condition Description</u>	<u>Tools</u>
2-8	Engine stopped.	Tool Kit, Service Refrigeration, item 5, Appendix B Tap and Die Set (5136-01-119-0005) item 3, Appendix B
4-15	Housing removed.	
5-3	Refrigeration system discharged.	
4-1	Engine oil drained.	

Materials/Parts:

Sealing Compound, item 27, Appendix E

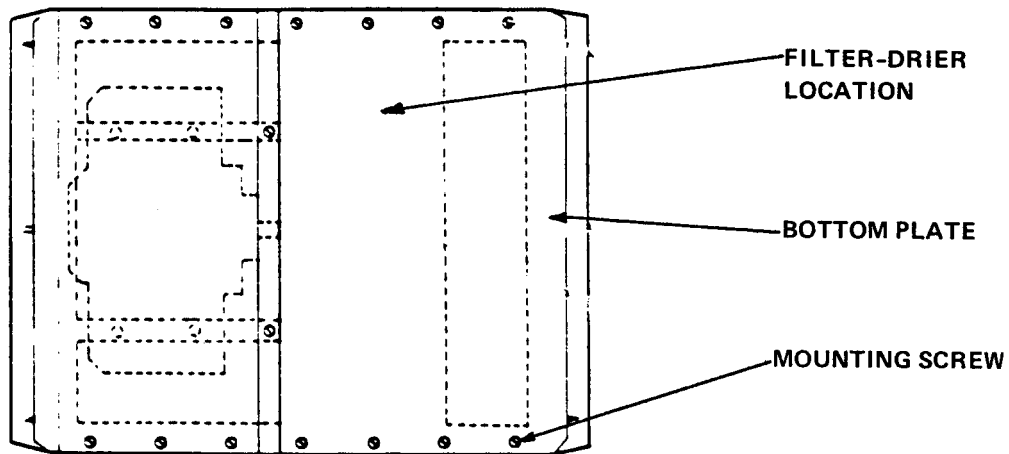

REMOVAL

1. Set water chiller on its side.
2. Remove 16 bottom plate mounting screws. Remove bottom plate from skid. Clean threads in skid using tap.

5-22. FILTER-DRIER REPLACEMENT (CONT)

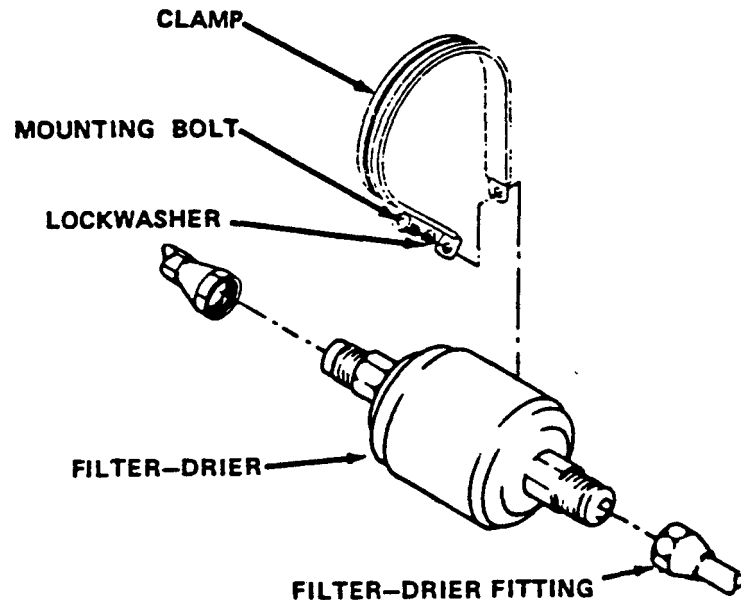

3. Remove clamp mounting bolt and flatwasher.
4. Remove filter-drier fittings. Remove filter-drier.
5. Slide clamp off filter-drier.

INSTALLATION

1. Slide new filter-drier into clamp.
2. Install clamp mounting bolt and flatwasher.
3. Connect filter-drier fittings.
4. Install bottom plate with 16 bottom plate mounting screws using sealing compound.
5. Set water chiller back on skid base.
6. Add oil (para 4-1).
7. Leak-test system (para 5-6).

5-22. FILTER-DRIER REPLACEMENT (CONT)

- 8. Evacuate system (para 5-7).
- 9. Charge system (para 5-8).

5-23. WATER SYSTEM LEAK TEST.

DESCRIPTION

This task covers: Testing Only

INITIAL SETUP

Equipment
Condition

<u>Para</u>	<u>Condition Description</u>	<u>Tools</u>
2-8	Engine stopped.	Tool Kit, General Mechanic's, item 1, Appendix B Tap & Die Set (5136-01-119-0005) item 3, Appendix B
4-15	Housing removed.	
4-1	Engine oil drained.	

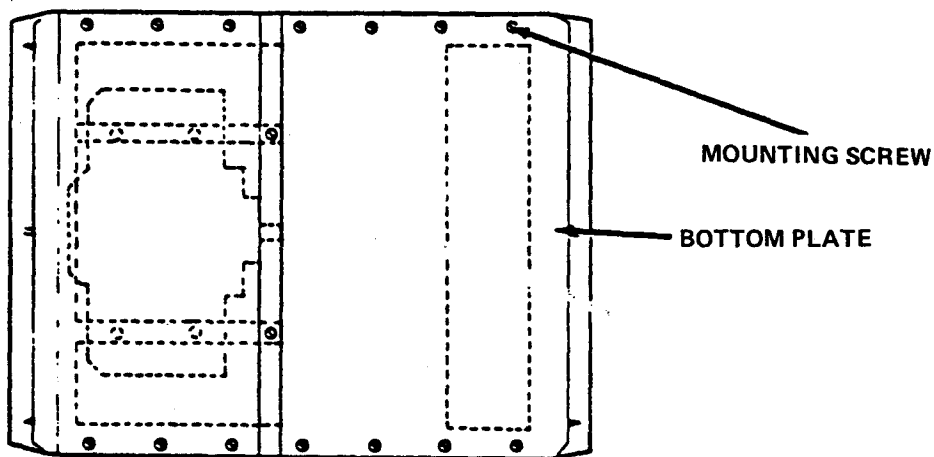

- 1. Set water chiller on its side.

5-23. WATER SYSTEM LEAK TEST (CONT)

2. Remove 16 bottom plate mounting screws. Remove bottom plate. Clean threads in skid with tap.

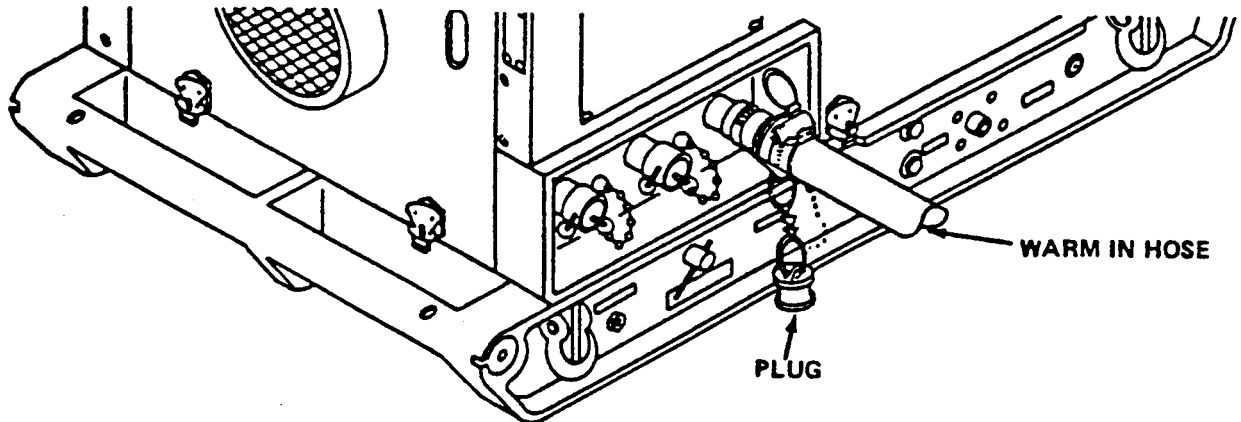

3. Place shipping plugs in COOL RECIRCULATE and COOL DISPENSE connections. Close cam arms.
4. Connect shop water source to WARM IN connection. Turn on water.
5. Check all fittings for leaks. Remove foam as necessary to locate leak.

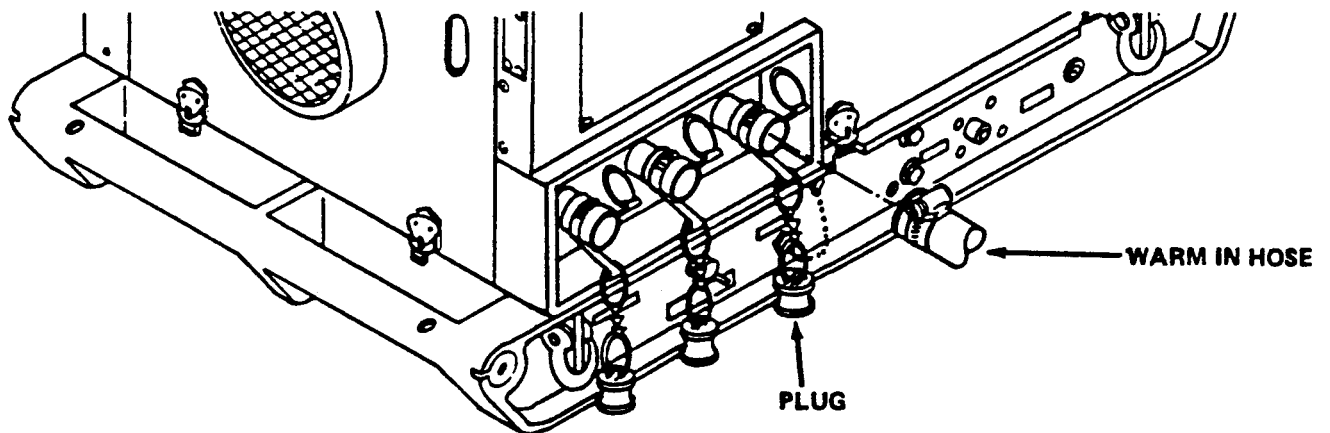

6. After 3 minutes turn off water. Remove shop water source from WARM IN connection. Remove shipping plugs from COOL RECIRCULATE and COOL DISPENSE connections. Set water chiller on base and allow water to drain.

5-23. WATER SYSTEM LEAK TEST (CONT)

- 7. Repair any leaks found and retest.
- 8. Add engine oil (para 4-1).

5-24. EVAPORATOR REPLACEMENT.

DESCRIPTION

This task covers: Removal and Installation

INITIAL SETUP

<u>Equipment Condition Para</u>	<u>Condition Description</u>	<u>Tools</u>
2-8	Engine stopped.	Tool Kit, Service Refrigeration, item 5, Appendix B
4-15	Housing removed.	Tap and Die Set (5136-01-119-0005) item 3, Appendix B
5-3	Refrigeration system discharged.	Wrench, Open End, item 3, Appendix B
4-1	Engine oil drained.	

Materials/Parts:

- Polyurethane foam, item 20, Appendix E
- Brazing alloy, item 6, Appendix E
- Mold Release, item 13, Appendix E
- Sealant Compound, item 27, Appendix E
- Strap, Tiedown MS3367-1-9
- Filter-Drier 13226E1786

5-24. EVAPORATOR REPLACEMENT (CONT)

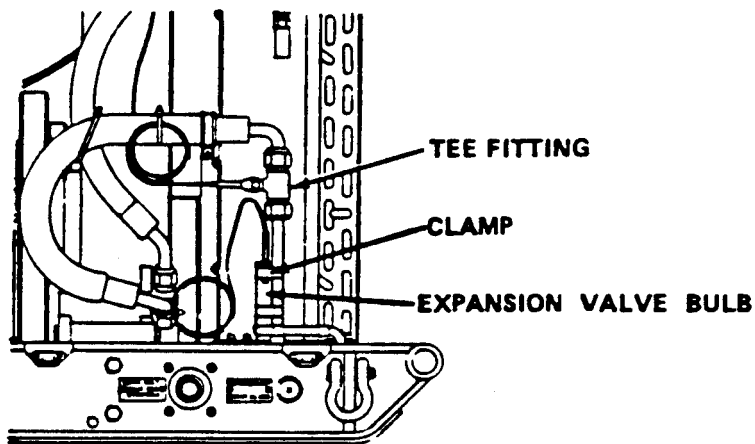

REMOVAL

1. Cut tie wraps holding insulation on expansion valve bulb.
2. Remove two clamps from expansion valve bulb and refrigerant line. Move bulb aside.
3. Remove evaporator pipe fitting from low pressure switch tee fitting.

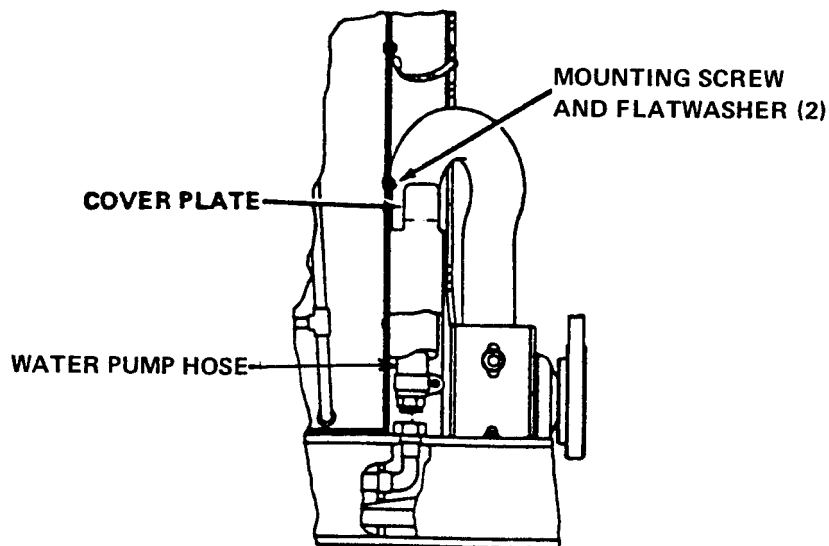

5-24. EVAPORATOR REPLACEMENT (CONT)

4. Remove two mounting screw and flatwasher. Remove upper water pump hose cover plate.
5. Pull back insulation, loosen hose clamp, and remove upper water pump hose.
6. Remove hose fitting from evaporator.

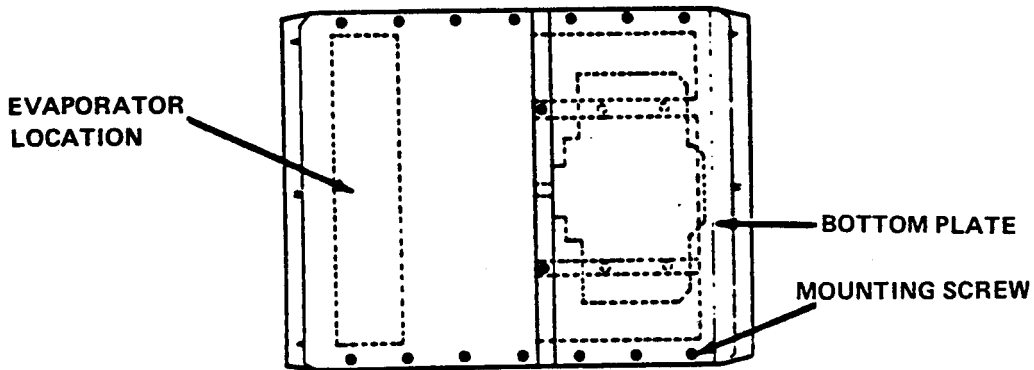

7. Set water chiller on its side.
8. Remove 16 bottom plate mounting screws. Remove bottom plate. Clean threads in skid base using tap.

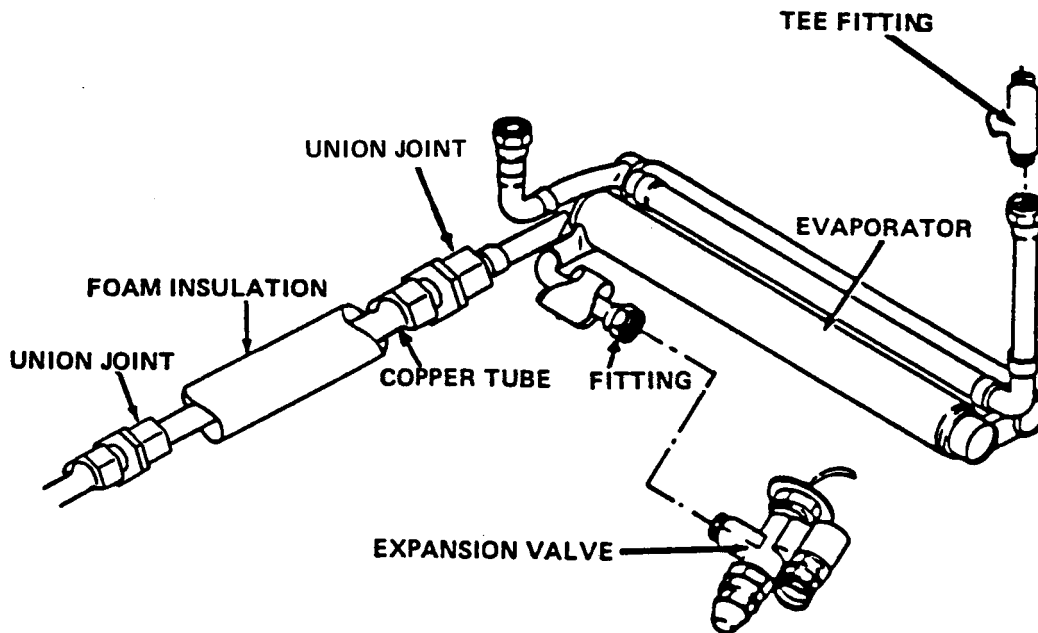

9. Break up foam around evaporator.

5-24. EVAPORATOR REPLACEMENT (CONT)

10. Remove evaporator pipe fitting from expansion valve.
11. Cut black foam insulation away from remaining evaporator fitting.
12. Break union joint fitting from copper tube.
13. Remove evaporator.

INSTALLATION

1. Install evaporator in skid base.
2. Install evaporator pipe fitting at expansion valve.
3. Connect union joint fitting to copper tubing.
4. Set water chiller on skid base.
5. Install hose fitting to evaporator.
6. Install upper water pump hose on hose fitting. Tighten hose clamp. Install black foam insulation.
7. Install water pump hose cover plate, with two mounting screws and flatwashers.
8. Install evaporator pipe fitting to low pressure switch tee fitting.
9. Fasten expansion valve bulb hose clamps to evaporator pipe.
10. Carefully slide expansion valve bulb down into clamps. Tighten clamps to ensure uniform contact.
11. Install black foam insulation over expansion valve bulb with tie wraps.
12. Set water chiller on its side.
13. Spray evaporator with mold release.
14. Fill in open areas with polyurethane foam.
15. Replace filter-drier before evacuating system (para 5-22).
16. Install bottom plate. Install 16 bottom plate mounting screws using sealing compound.
17. Set water chiller on skid base.

5-24. EVAPORATOR REPLACEMENT (CONT)

- 18. Add oil (para 4-1).
- 19. Leak-test system (para 5-6).
- 20. Evacuate system (para 5-7).
- 21. Charge system (para 5-8).

5-25. RELIEF VALVE REPLACEMENT.

DESCRIPTION

This task covers: Removal and Installation

INITIAL SETUP

Equipment
Condition
Para

Condition Description

Tools

- 2-8 Engine stopped.
- 4-15 Housing removed.
- 4-25 Engine removed.

- Tool Kit, General
Mechanic's, item 1,
Appendix B
- Riveter, Blind, Hand
(5120-00-017-2849),
item 10, Appendix B
- Drill, Potable, 1/4
(5130-00-807-3009)
item 3, Appendix B
- Drill, Set Twist
(5133-00-293-0983)
item 3, Appendix B

Materials/Parts:

- Polyurethane foam, item 20,
Appendix E
- Mold release, item 13, Appendix E
- Rivet M24243/1-A405
- Lockwasher MS35338-138

5-25. RELIEF VALVE REPLACEMENT (CONT)

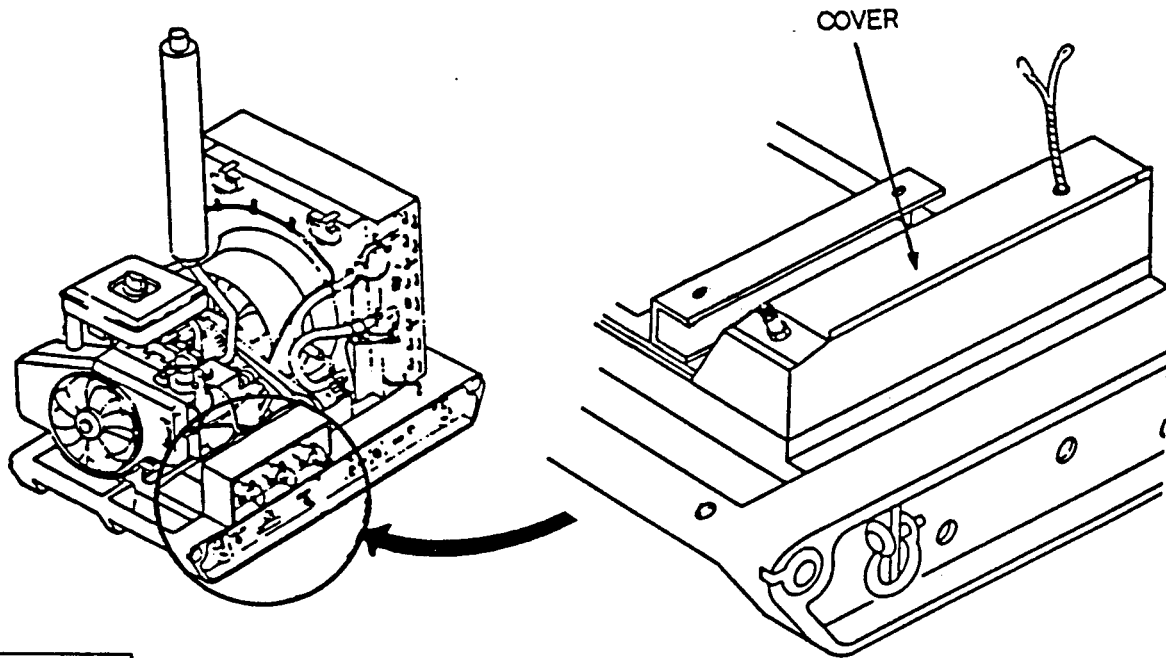

REMOVAL

1. Drill out six rivets securing cover to rear panel assembly.
2. Remove cover. Break-up foam around relief valve and flange adapters.

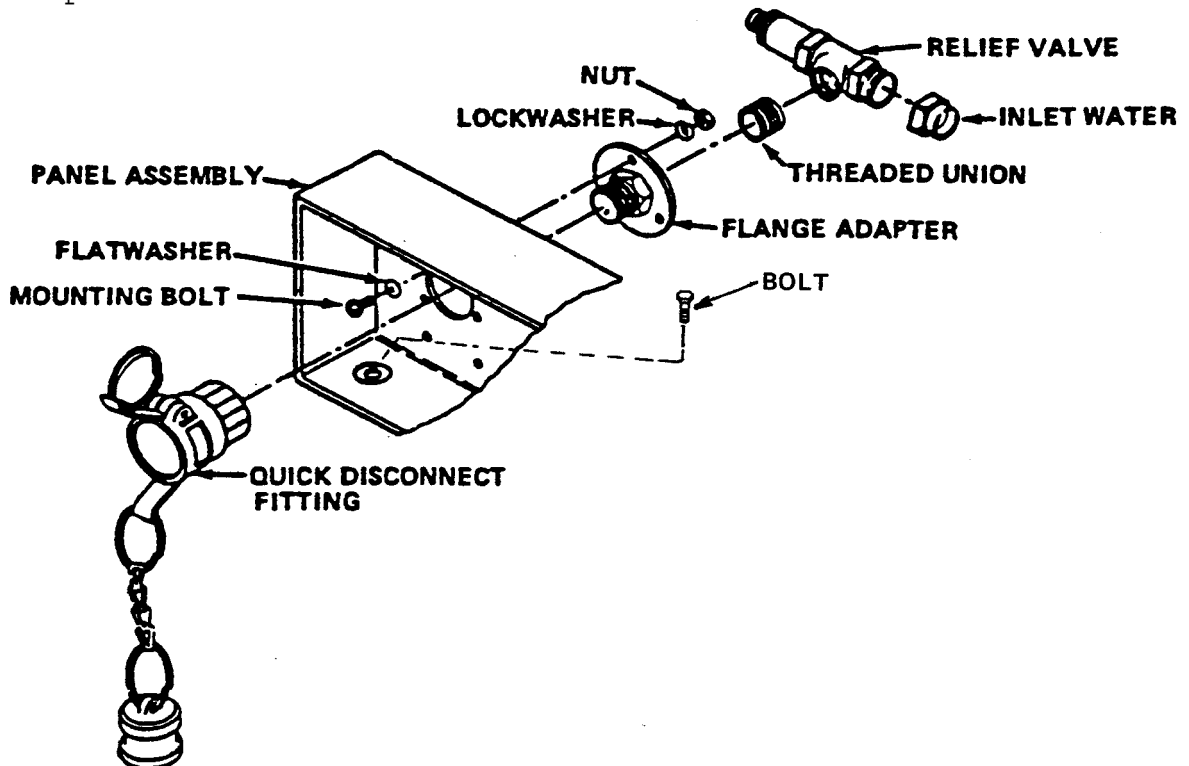

5-25. RELIEF VALVE REPLACEMENT (CONT)

3. Remove three quick disconnect fittings.
4. Remove nine mounting bolts, flatwashers, lockwashers, and nuts securing three flange adapters to panel assembly.
5. Remove three bolts securing panel assembly to skid.
6. Remove panel assembly.
7. Remove flange adapter from threaded union on relief valve.
8. Remove threaded union from relief valve.
9. Remove relief valve from inlet water fitting.

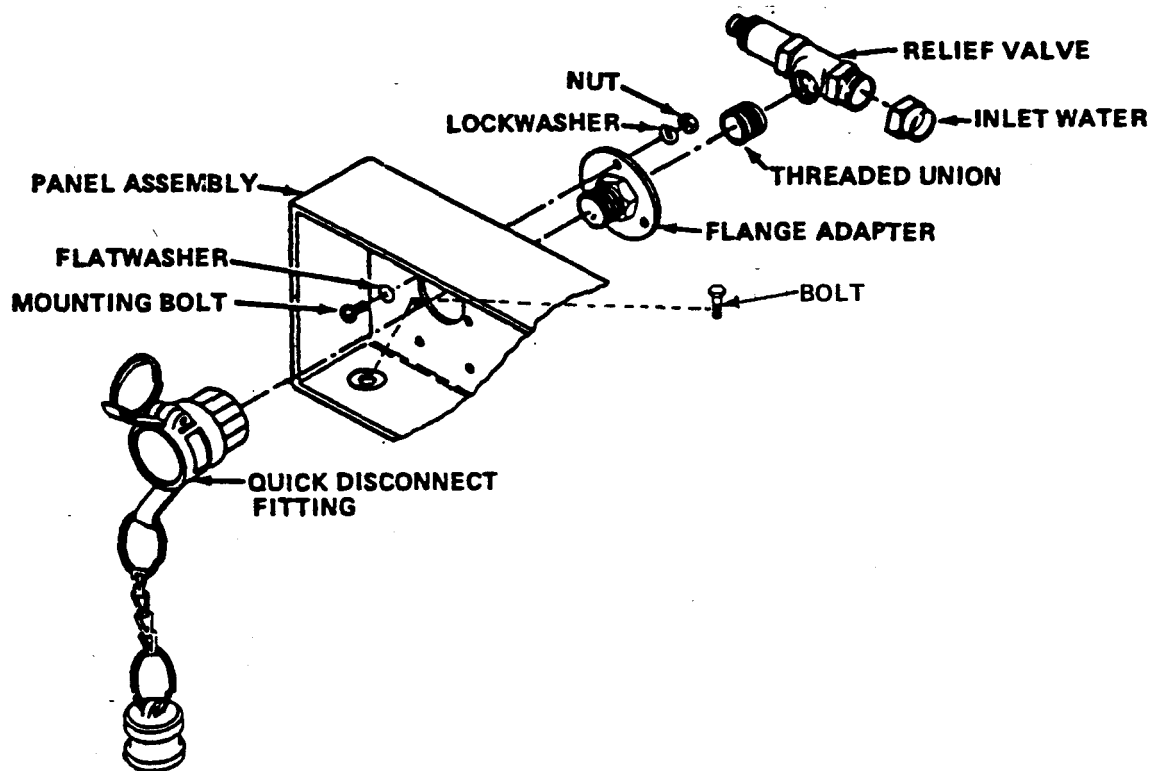

INSTALLATION

1. Install relief valve in water fitting.
2. Insert threaded union and flange adapter.

5-25. RELIEF VALVE REPLACEMENT (CONT)

3. Align panel assembly with all holes in skid and flange adapters.
4. Install three bolts securing panel assembly to skid.
5. Install nine mounting bolts, flatwashers, lockwashers, and nuts securing three flange adapters to panel assembly.
6. Install three quick disconnect fittings to flange adapters.

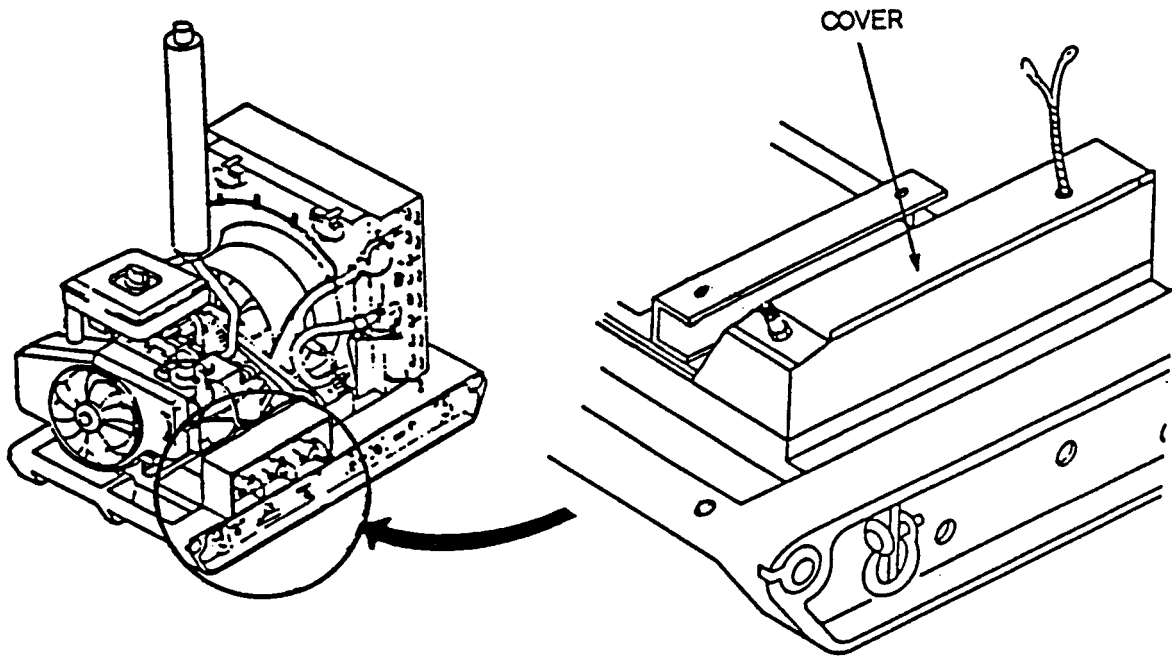

7. Spray mold release on flange adapters and relief valve.
8. Install cover with rivets.
9. Spray foam in cover.
10. Install engine (para 4-25).

5-26. THERMOSTATIC VALVE REPLACEMENT.

DESCRIPTION

This task covers: Removal and Installation

INITIAL SETUP

Equipment Condition

<u>Para</u>	<u>Condition Description</u>	<u>Tools</u>
2-8	Engine stopped.	Tool Kit, General Mechanic's, item 1, Appendix B Tap and Die Set (5136-01-119-0005), item 3, Appendix B
4-15	Housing removed.	
4-1	Engine oil drained.	

Materials/Parts:

- Polyurethane foam, item 20, Appendix E
- Mold Release, item 13, Appendix E
- Sealant Compound, item 27, Appendix E

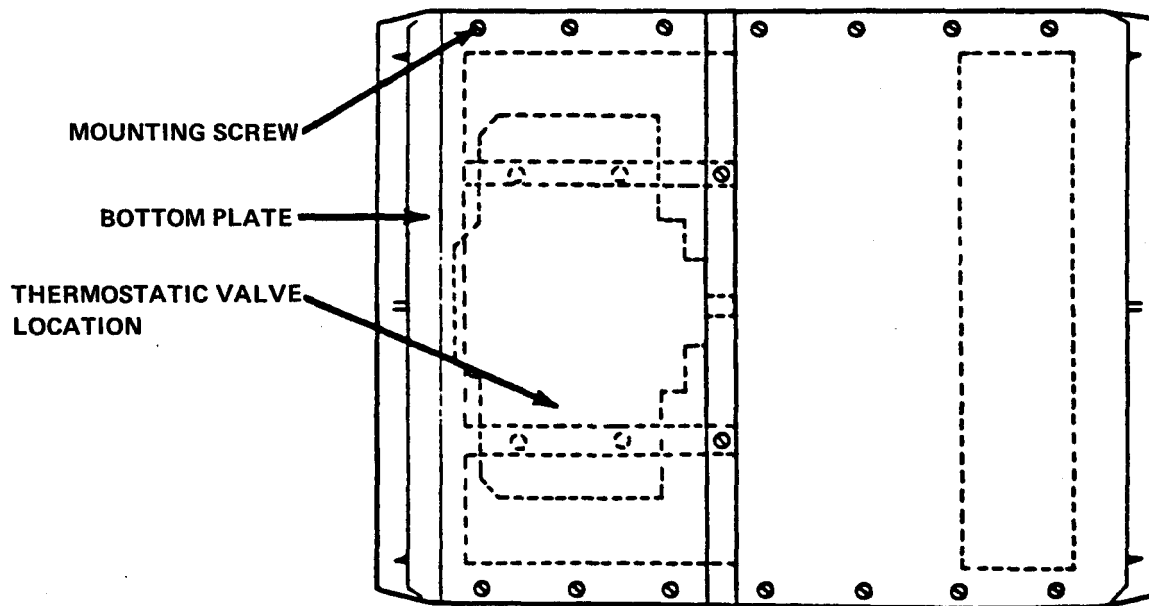

REMOVAL

1. Split union on fuel line at skid where flexible fuel hose attaches.

5-26. THERMOSTATIC VALVE REPLACEMENT (CONT)

2. Set water chiller on its side.
3. Remove 16 bottom plate mounting screws. Remove bottom plate. Clean threads in skid base using tap.
4. Break up foam around thermostatic valve and heat exchanger.

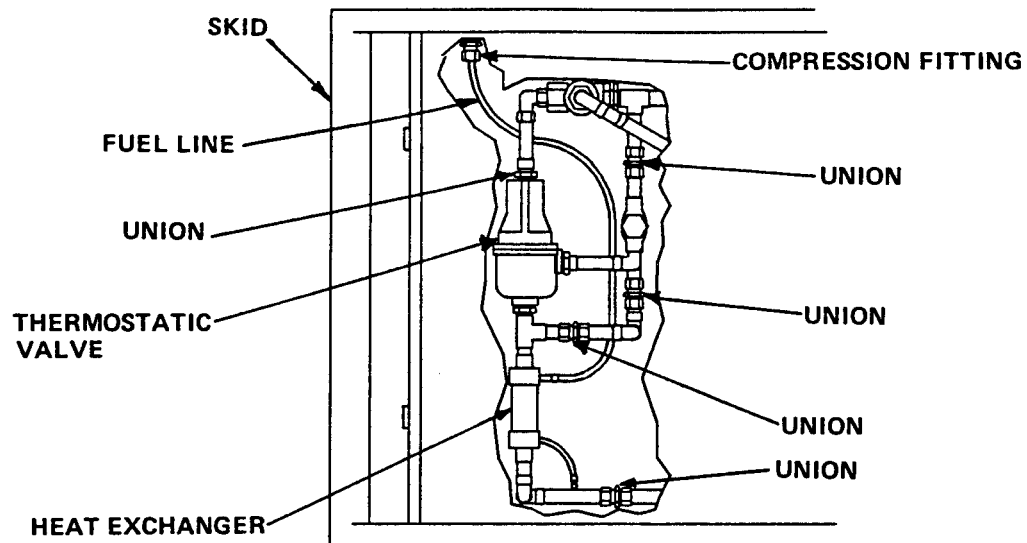

5. Disconnect compression fitting on end of the fuel heat exchanger line.
6. Disconnect all union joints on water system.
7. Remove thermostatic valve and fuel heat exchanger as one assembly.

5-26. THERMOSTATIC VALVE REPLACEMENT (CONT)

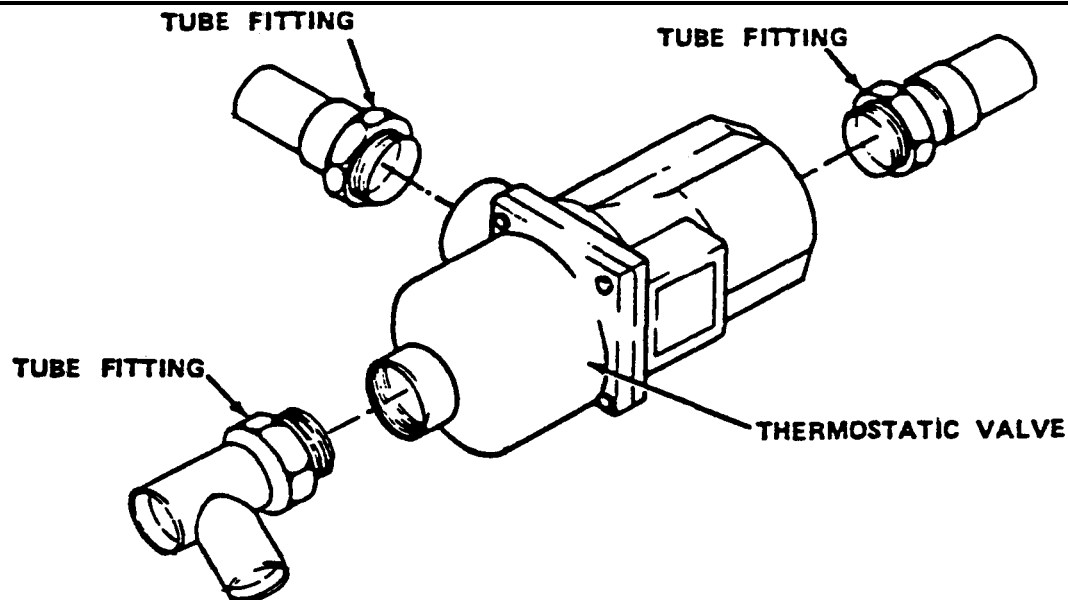

8. Remove tubing subassemblies from thermostatic valve.

INSTALLATION

1. Install tubing subassemblies on thermostatic valve.
2. Place thermostatic valve and fuel heat exchanger in skid as one assembly.
3. Connect union joints on water system.
4. Connect compression fitting on end of the fuel heat exchanger.
5. Spray thermostatic valve and fuel heat exchanger with mold release.
6. Fill in open areas with polyurethane foam.
7. Install bottom plate. Install 16 bottom plate mounting screws using sealing compound.
8. Set water chiller on skid base.
9. Attach fuel line to union.
10. Add oil (para 4-1).

5-27. THERMOSTATIC VALVE REPAIR.

DESCRIPTION

This task covers: Disassembly and Assembly

INITIAL SETUP

Equipment

Condition

Para

Condition Description

Tools

2-8

Engine stopped.

Tool Kit, General
Mechanic's, item 1,
Appendix B

4-15

Housing removed.

5-26

Thermostatic valve
removed.

Materials/Parts:

Grease, item 16, Appendix E

Lockwashers MS35307-308

Packing, Preformed (94607) 1205

Seal (94607) 277L145

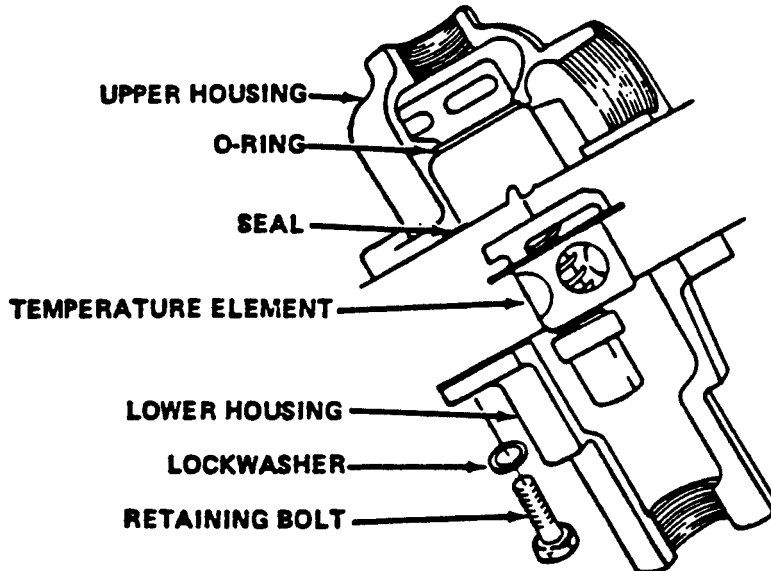

5-27. THERMOSTATIC VALVE REPAIR (CONT)

DISASSEMBLY

1. Remove four lower housing retaining bolts and lockwashers.
2. Separate lower housing from upper housing.
3. Remove seal.
4. Remove temperature element assembly.
5. Remove packing from temperature element assembly.

ASSEMBLY

1. Lubricate packing and seal with a light coat of grease.
2. Install packing on new temperature element assembly.
3. Install temperature element assembly in upper housing.
4. Install seal in upper housing.
5. Install lower housing on upper housing.
6. Install four lower housing retaining bolts and lockwashers.
7. Install thermostatic valve (para 5-26).

5-28. START-RUN VALVE ASSEMBLY REPLACEMENT.

DESCRIPTION

This task covers: Removal and Installation

INITIAL SETUP

Equipment
Condition

<u>Para</u>	<u>Condition Description</u>	<u>Tools</u>
2-8	Engine stopped.	Tool Kit, Service Refrigeration, item 5, Appendix B Tap and Die Set (5136-01-119-0005), item 3, Appendix B
4-15	Housing removed.	
5-29	Low temperature switch removed.	

5-28. START-RUN VALVE ASSEMBLY REPLACEMENT (CONT)

Equipment
Condition

<u>Para</u>	<u>Condition Description</u>	<u>Tools</u>
5-26	Thermostatic valve removed.	

Materials/Parts:

Polyurethane Foam, item 20, Appendix E
 Mold Release, item 13, Appendix B
 Solder, item 29, Appendix B
 Sealant, Compound, item 27, Appendix E

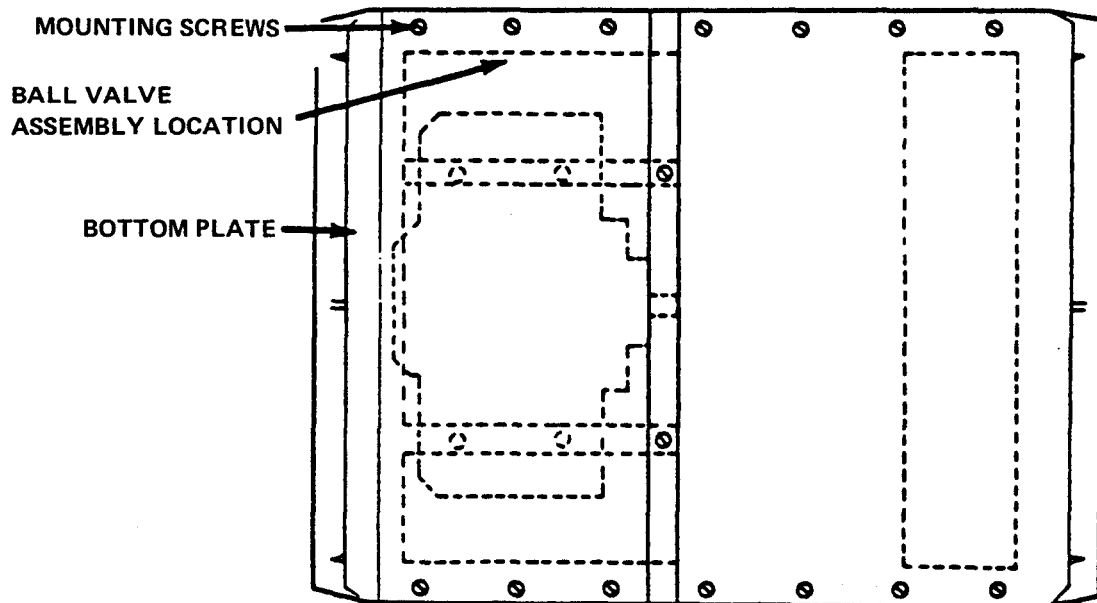

REMOVAL

1. Set water chiller on its side.
2. Remove 16 bottom plate mounting screws. Remove bottom plate. Clean threads in skid hose using tap.
3. Break up foam insulation around START-RUN valve assembly.

5-28. START-RUN VALVE ASSEMBLY REPLACEMENT (CONT)

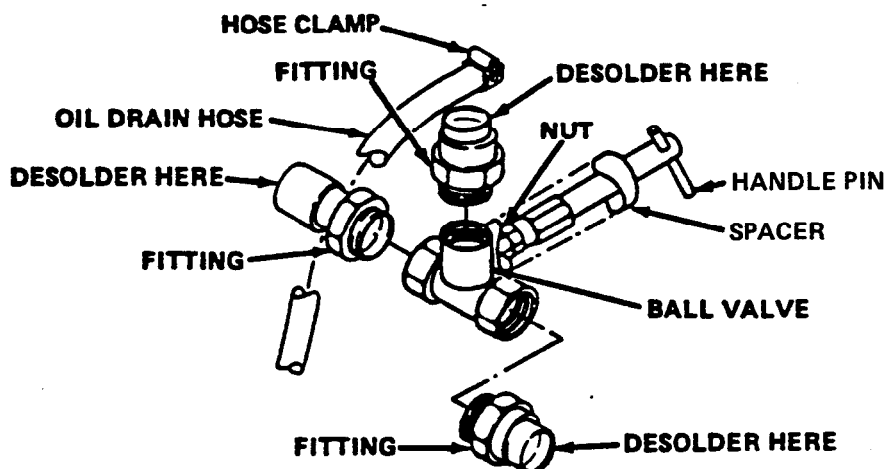

4. Remove oil drain hose clamp. Move oil drain hose out of way.
5. Drive out handle pin.

WARNING

Polyurethane foam is flammable. Burning foam causes toxic fumes. When soldering, be very careful not to ignite foam.

NOTE

Desolder fittings as needed to remove from valve assembly.

6. Debraze START-RUN valve assembly (para 5-5).
7. Remove spacer.
8. Remove three fittings from valve assembly.

INSTALLATION

1. Install three fittings in valve assembly.
2. Install spacer.

5-28. START-RUN VALVE ASSEMBLY REPLACEMENT (CONT)

3. Install START-RUN valve assembly in bottom of skid.

WARNING

Polyurethane foam is flammable. Burning foam causes toxic fumes. When soldering, be very careful not to ignite foam.

4. Braze three fittings to tubing (para 5-5).
5. Attach oil drain hose and tighten clamp.
6. Install thermostatic valve (para 5-26).
7. Perform water leak test (para 5-23).
8. Spray mold release in open area.
9. Fill in open area with polyurethane foam.
10. Install bottom plate with 16 bottom plate mounting screws using sealing compound.
11. Set water chiller on skid base.
12. Install pin.
13. Install low temperature switch (para 4-29).

5-29. LOW TEMPERATURE THERMAL SWITCH REPLACEMENT.

DESCRIPTION

This task covers: Removal and Installation

INITIAL SETUP

<u>Equipment Condition Para</u>	<u>Condition Description</u>	<u>Tools</u>
2-8	Engine stopped.	Tool Kit, General
4-15	Housing removed.	Mechanic's, item 1, Appendix B
4-25	Engine removed.	Riveter, Blind, Hand (5120-00-017-2849) , item 10, Appendix B

5-29. LOW TEMPERATURE THERMAL SWITCH REPLACEMENT (CONT)

Materials/Parts:

Polyurethane Foam, item 20,
Appendix E
Mold Release, item 13,
Appendix E
Rivet M24243/1-A405
Strap, Tie Down MS3367-1-9
Adhesive, Sealant, item 13,
Appendix E
Solder, item 30, Appendix E
Adhesive, Epoxy, item 2, Appendix E

Tools

Drill, Potable, 1/4
(5130-00-807-3009), item 3,
Appendix B
Drill, Set Twist
(5133-00-293-0983), item 3,
Appendix B
Soldering Gun, (3439-00-542-
0396), item 3, Appendix B

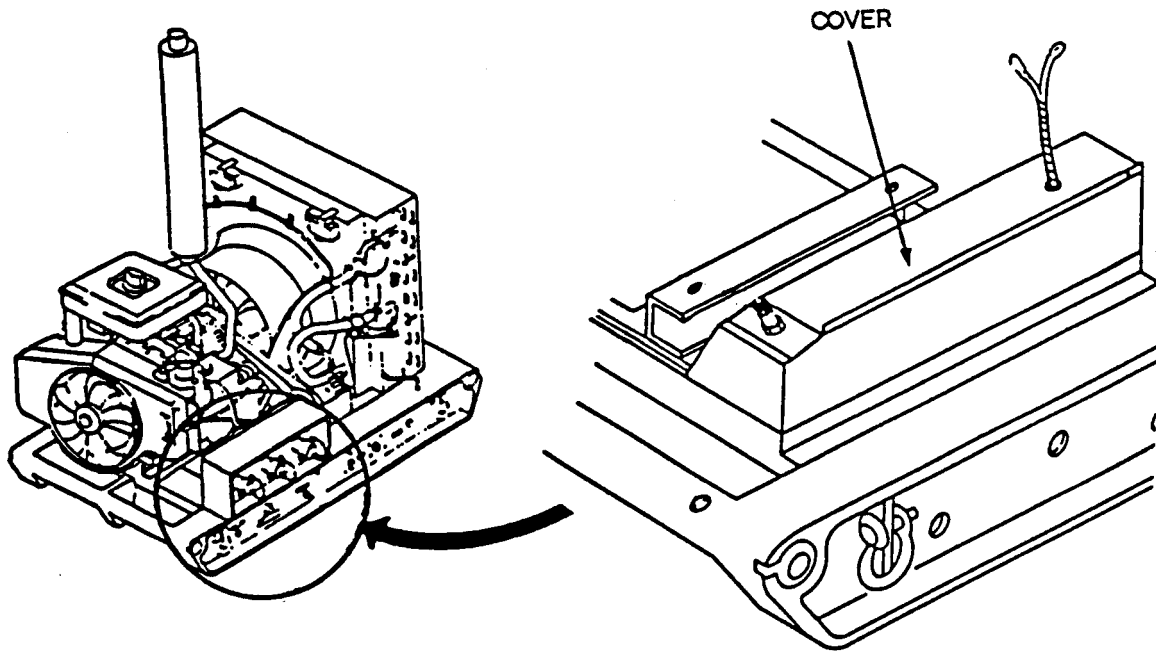

REMOVAL

1. Drill out six rivets securing cover to rear panel assembly.
2. Remove cover.

5-29. LOW TEMPERATURE THERMAL SWITCH REPLACEMENT (CONT)

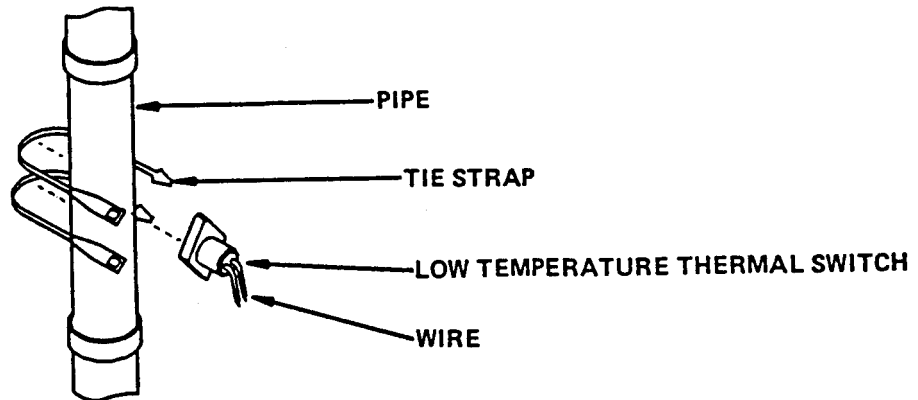

3. Break up foam insulation to gain access to thermal switch located on the side of warm (inlet) pipe.

WARNING

Polyurethane foam is flammable. Burning foam causes toxic fumes. When soldering, be very careful not to ignite foam.

4. Desolder two wires from thermal switch. Remove wires.
5. Pry thermal switch away from pipe.

INSTALLATION

1. Place new switch against pipe at removal site.
2. Using bonding compound, bond switch to pipe. Let compound dry until it hardens.
3. Use tiedown straps to secure switch to pipe.
4. Seal any gaps between switch and pipe with sealant.

NOTE

Wire must be fed through cover before attaching wires to switch.

5. Attach one wire to each thermal switch terminal. (Reversing wires does not matter.)
6. Solder two wires to thermal switch terminals.
7. Spray with mold release.
8. Install cover.
9. Fill in all open areas with polyurethane foam.
10. Install engine (para 4-25).

5-30. HEAT EXCHANGER REPLACEMENT.

DESCRIPTION

This task covers: Removal and Installation

INITIAL SETUP

Equipment
Condition

<u>Para</u>	<u>Condition Description</u>	<u>Tools</u>
2-8	Engine stopped.	Tool Kit, Service Refrigeration, item 5, Appendix B Tap and Die Set, item 3, Appendix B
4-15	Housing removed.	
4-1	Engine oil drained.	

Materials/Parts:

- Brazing Alloy, item 6, Appendix E
- Polyurethane Foam, item 20, Appendix E
- Mold Release, item 13, Appendix E
- Sealant Compound, item 27, Appendix E

HEAT EXCHANGER LOCATION

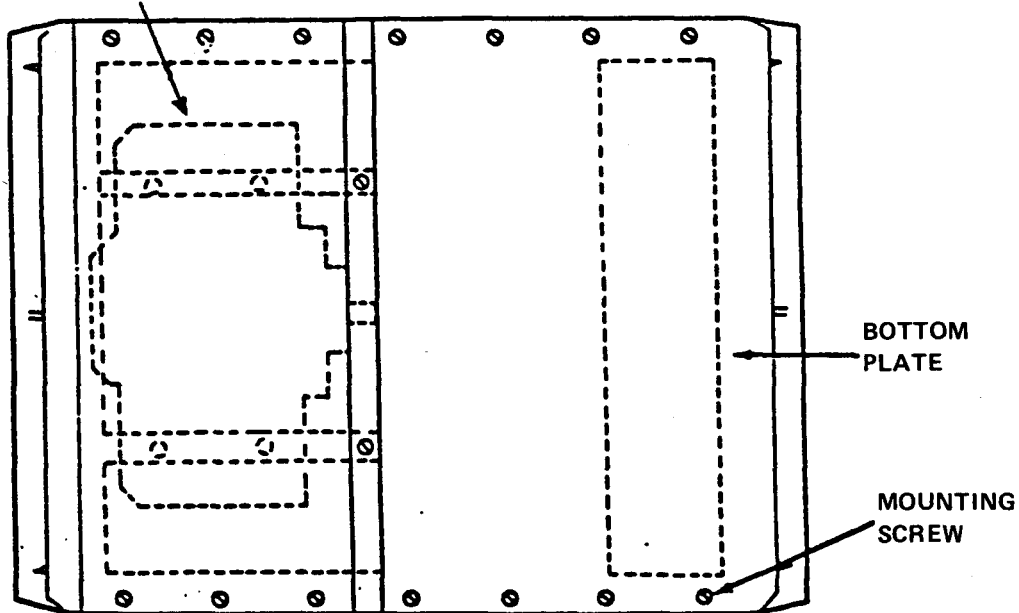

5-30. HEAT EXCHANGER REPLACEMENT (CONT)

REMOVAL

1. Turn water chiller on its side.
2. Remove 16 bottom plate mounting screws. Remove bottom plate. Clean threads in skid base with tap.

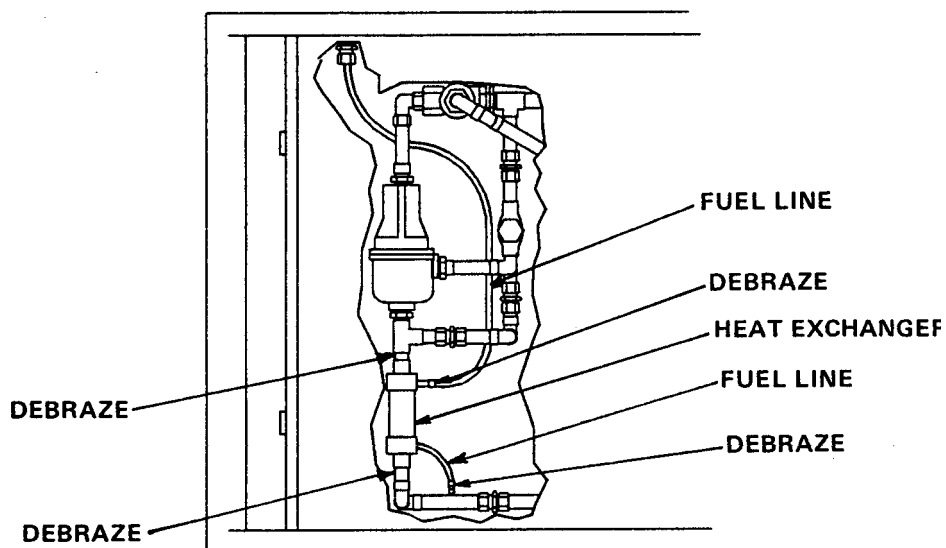

3. Break up foam insulation to gain access to heat exchanger.

WARNINGS

Polyurethane foam is flammable. Burning foam causes toxic fumes. When soldering, be very careful not to ignite foam.

Gas fumes are explosive. Flush fuel lines prior to applying heat to brazing.

4. Debraze heat exchanger from tubing (para 5-5).

INSTALLATION

1. Braze heat exchanger to tubing (para 5-5).
2. Leak check heat exchanger (para 5-23).
3. Spray mold release in open area.

5-30. HEAT EXCHANGER REPLACEMENT (CONT)

4. Fill in all open areas with polyurethane foam.
5. Install bottom plate with 16 bottom plate mounting screws using sealing compound.
6. Set water chiller on skid.
7. Add oil (para 4-1).

5-31. SKID REPLACEMENT.

DESCRIPTION

This task covers: Removal and Installation

INITIAL SETUP

Equipment
Condition

<u>Para</u>	<u>Condition Description</u>	<u>Tools</u>
2-8	Engine stopped.	Tool Kit, General Mechanic's, item 1, Appendix B
4-15	Housing removed.	Drill, Potable, 1/4 inch, (5130-00-807- 3009), item 3, Appendix B
4-25	Engine removed.	Drill, Set Twist (5133-00-293-0983) , item 3, Appendix B
4-37	Water pump removed.	Riveter, Blind, Hand (5120-00-017-2849) , item 10, Appendix B
4-40	STARTER connection assembly removed.	
5-13	Compressor suction hose removed.	
5-14	Compressor discharge hose removed.	<u>Materials/Parts:</u>
5-17	Condenser removed.	Rivet M24243/1-A405 Rivet M24243/1-A403
5-19	Expansion valve removed.	Lockwasher MS35338-138 Lockwasher MS35338-135
5-20	Compressor removed.	
5-24	Evaporator removed.	
5-25	Relief valve removed.	
5-26	Thermostatic valve removed.	

5-31. SKID REPLACEMENT (CONT)

Equipment Condition Para	Condition Description	Tools
5-28	START-RUN valve removed.	
5-29	Low temperature thermal switch removed.	
5-30	Heat exchanger removed.	

REMOVAL

1. Remove four shackles.
2. Remove MOGAS and oil couplings.

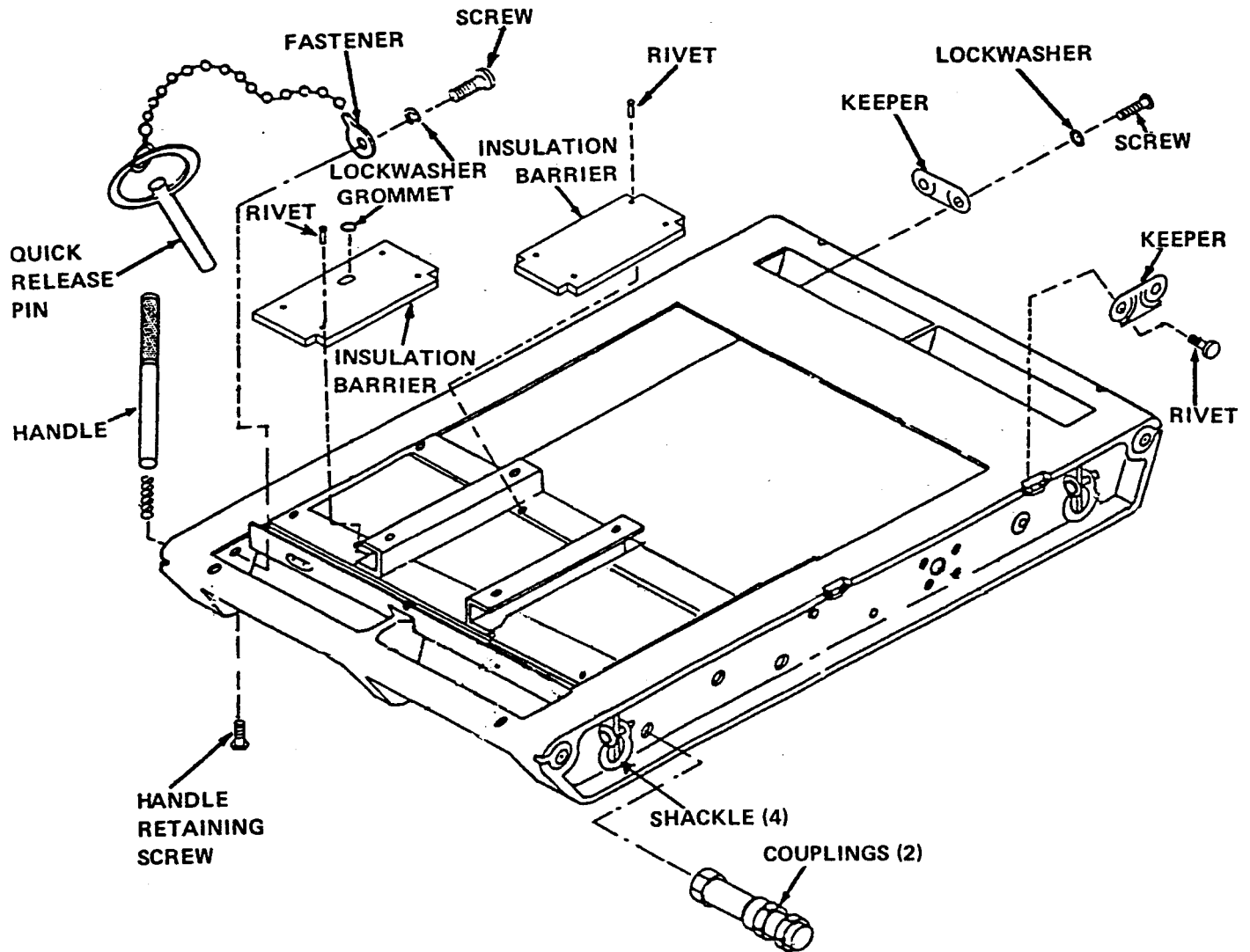

5-31. SKID REPLACEMENT (CONT)

3. Remove grommet from insulation barrier.
4. Drill out rivets and remove insulation barriers.
5. Drill out rivets or remove screws and lockwashers securing keepers. Remove keepers.
6. Remove screw and lockwasher securing bead chain fastener to skid. Remove quick release pin and chain.
7. Remove handle retaining screw securing handle and spring to skid. Remove handle and spring.

INSTALLATION

1. Install handle retaining "screw while holding handle and spring in place.
2. Attach quick release pin chain and fastener to skid with screw and lockwasher.
3. Attach keepers to skid with rivet or screws and lockwashers.
4. Align holes and rivet insulation barriers to skid.
5. Insert grommet into insulation barrier.
6. Install panel couplings.
7. Attach four shackles.

5-32. TRAILER MOUNTING KIT INSTALLATION.

DESCRIPTION

This task covers: Installation

INITIAL SETUP

Tools

Tool Kit, General Mechanic's,
item 1, Appendix B

Materials/Parts:

Welding Rods, item 25,
Appendix E

Personnel Required:

Four to lift water chiller.

5-32. TRAILER MOUNTING KIT INSTALLATION (CONT)

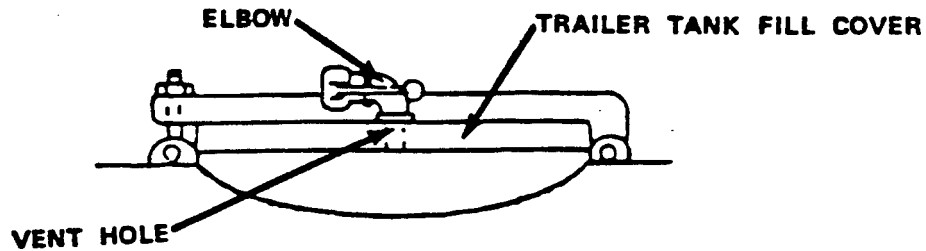

(LOCATED AT TOP OF TRAILER TANK)

1. Remove pipe plug from vent hole in trailer tank fill cover.
2. Install quick-disconnect elbow connection into vent hole in trailer tank fill cover.

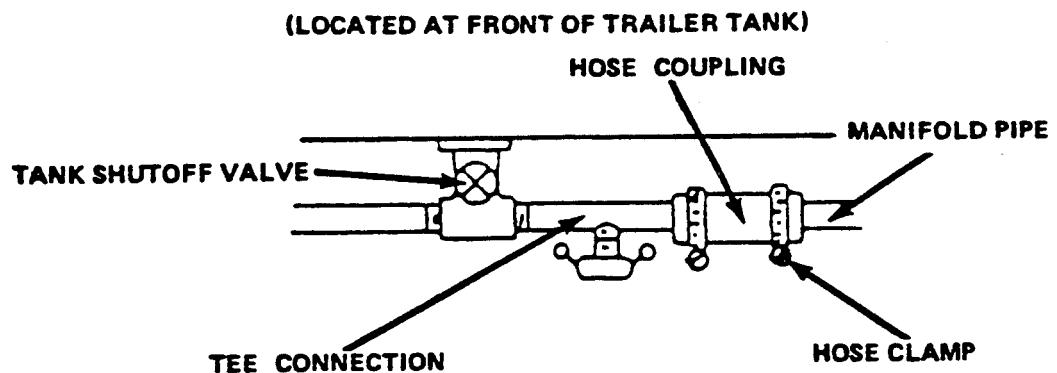

3. Loosen hose clamp on hose coupling from trailer tank manifold pipe.
4. Remove hose coupling from manifold pipe.
5. Remove pipe nipple from tank shutoff valve and install T-connection with quick-disconnect.
6. Install hose coupling and hose clamps between T-connection and manifold pipe.

5-32. TRAILER MOUNTING KIT INSTALLATION (CONT)

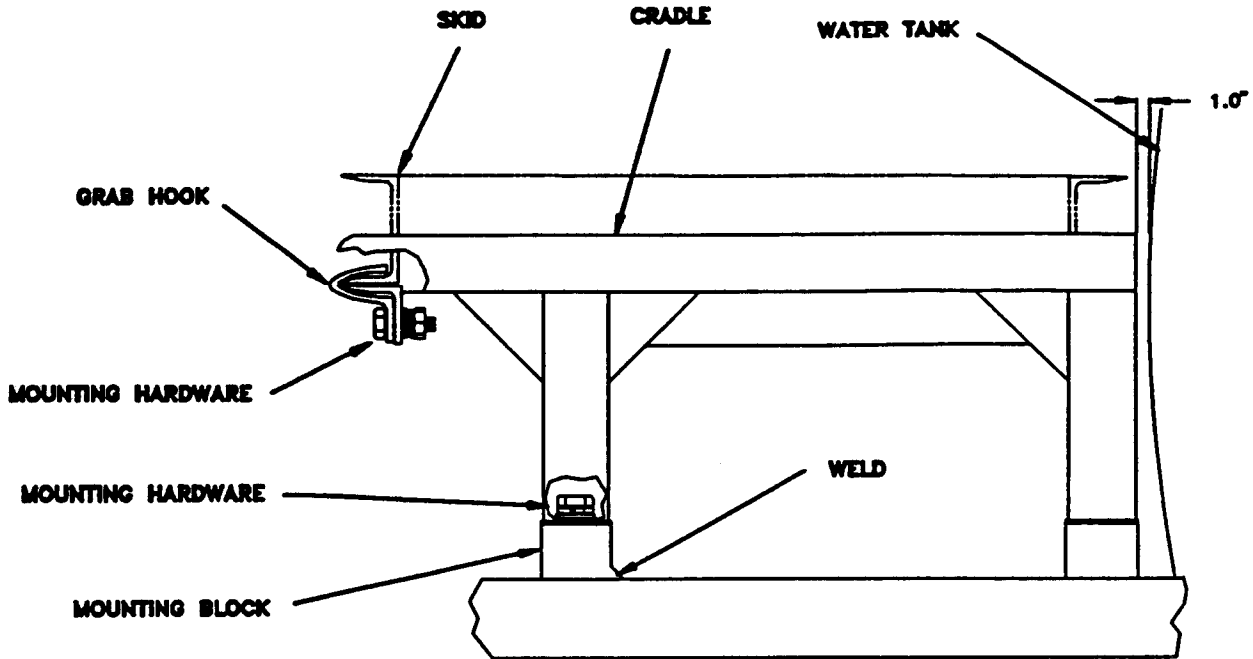

WARNING

To prevent injury, four persons are required for next step.

7. Bolt mounting blocks to legs of cradle.
8. Using four people to lift, install water chiller in cradle with bottom of skid in locked position at rear of cradle.
9. Place grab hooks over flange of front skid and bolt to cradle.
10. Lift assembly on to trailer frame.
11. Center unit on trailer and locate as far forward as possible on tongue.
12. Weld mounting blocks to trailer frame.

CHAPTER 6

GENERAL SUPPORT MAINTENANCE

6-1. SCOPE . General Support Maintenance of the water chiller consists of repair of the engine assembly.

6-2. CYLINDER BLOCK ASSEMBLY REPAIR.

DESCRIPTION

This task covers: Disassembly, Servicing, and Assembly

INITIAL SETUP

Equipment
Condition

<u>Para</u>	<u>Condition Description</u>	<u>Tools</u>
4-15	Housing removed.	Torque Wrench, item 6, Appendix B
4-25	Engine removed.	Tool Kit, General Mechanic's, item 1, Appendix B
4-22	Fan assembly removed.	Puller Kit, item 2, Appendix B
4-23	Centrifugal clutch assembly.	Lifter, Valve Spring, item 6, Appendix B
4-32	Dipstick and tube assembly removed.	Reamer, Hand, item 6, Appendix B
4-27	Carburetor and intake manifold removed.	Gauge Set, Telescoping, item 6, Appendix B
4-28	Governor removed.	Compressor, Piston Ring, item 6, Appendix B
5-11	Cylinder head assemblies removed.	Tool Kit, Valve Seat Ring, item 6, Appendix B
4-33	Starter removed.	Dial Indicator Set, item 6, Appendix B
4-31	Armature group removed.	<u>Materials/Parts:</u>
4-34	Flywheel and ring gear assembly removed.	Solvent, dry cleaning, item 31, Appendix E
4-24	Exhaust system removed.	Plastic-gauge, item 21, Appendix E
4-45	Breather assembly removed.	Compound, lapping, item 9, Appendix E
		Seal (08645) 393606
		Engine oil, item 17, Appendix E

6-2. CYLINDER BLOCK ASSEMBLY REPAIR (CONT)

Special Tools

Valve guide plug gauge,
item 12, Appendix B
Valve guide tool kit, item 11,
Appendix B
Valve seat puller kit, item 13,
Appendix B

Materials/Part:

Grease, item 15, Appendix E
Kerosene, item 22, Appendix E
Lapping compound, item 9,
Appendix E
Solvent, item 31, Appendix E

Personnel Required:

Two to lift engine.

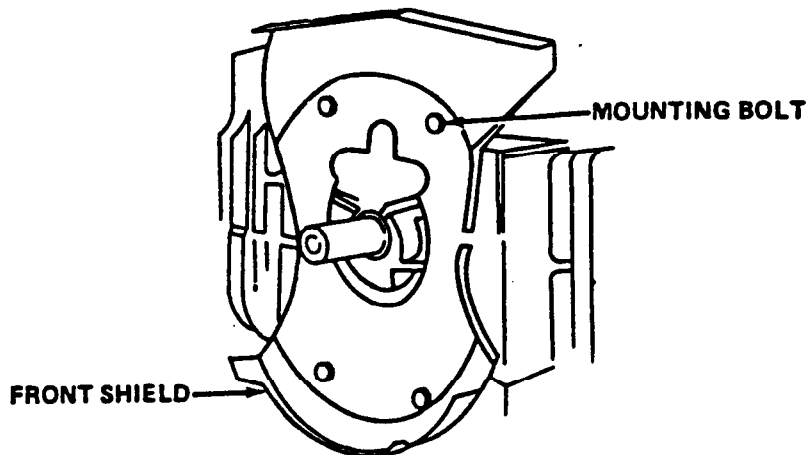

DISASSEMBLY

1. Remove four mounting bolts and lockwashers.
2. Remove front shield.

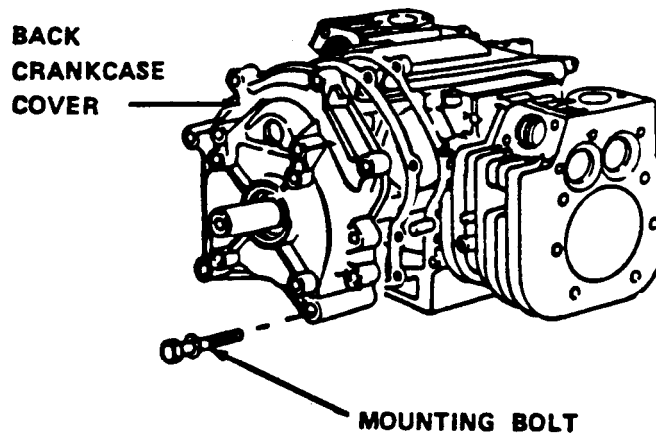

6-2. CYLINDER BLOCK ASSEMBLY REPAIR (CONT)

3. Remove three remaining back crankcase cover mounting bolts.
4. Tap gently on each side of back cover to loosen. Pull cover assembly off.

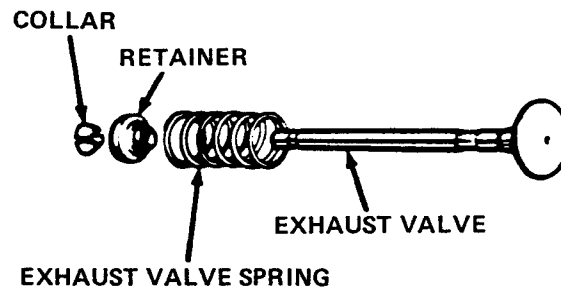

NOTE

DO NOT interchange parts when removing valves, valve springs, and tappets. Tappets must clear cam lobes before camgear can be removed.

5. Using valve spring compressor, compress exhaust spring. Remove valve spring collars. Remove valve spring compressor. Remove exhaust valve, spring and retainer.

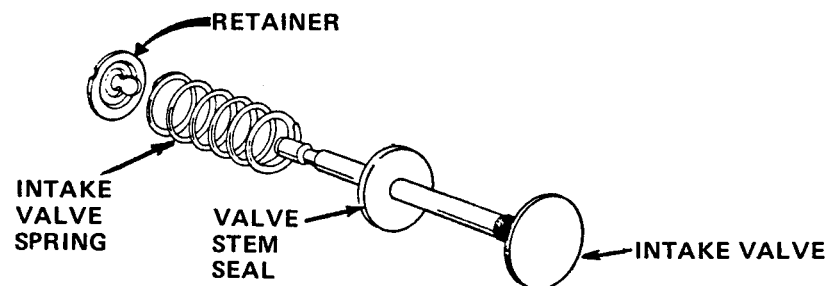

CAUTION

Pull out intake valve slowly to prevent damaging seal.

NOTE

Apply engine oil to stem while pulling out valve.

6. Slip jaw of valve spring compressor between spring and retainer. Compress valve spring. Slide valve spring retainer off valve stem. Remove valve spring compressor. Remove intake valve, spring and seal. Discard seal.

6-2. CYLINDER BLOCK ASSEMBLY REPAIR (CONT)

7. Repeat steps 5 and 6 for other exhaust and intake valves.

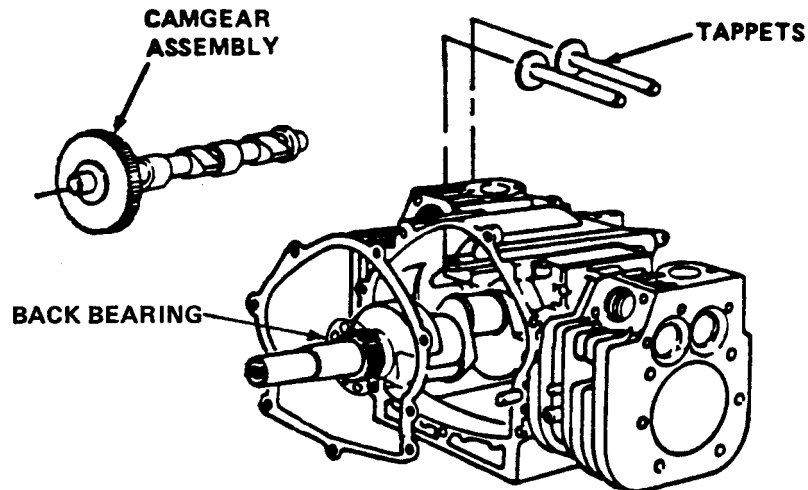

8. Remove back bearing.

9. Remove camgear assembly. Remove four tappets.

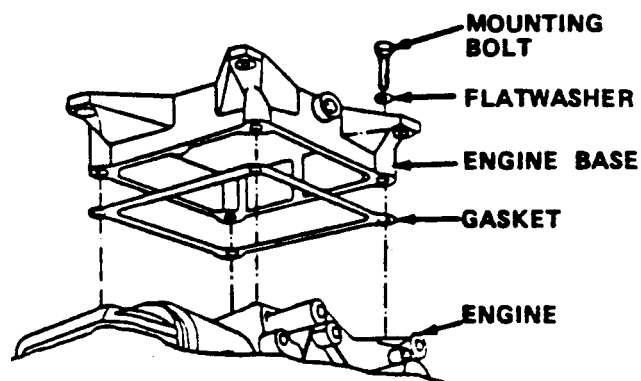

NOTE

Two persons are required for next step.

10. Turn engine upside down. Remove four engine base mounting bolts, flatwashers, and gasket.

11. Rotate crankshaft until right piston is at top dead center.

6-2. CYLINDER BLOCK ASSEMBLY REPAIR (CONT)

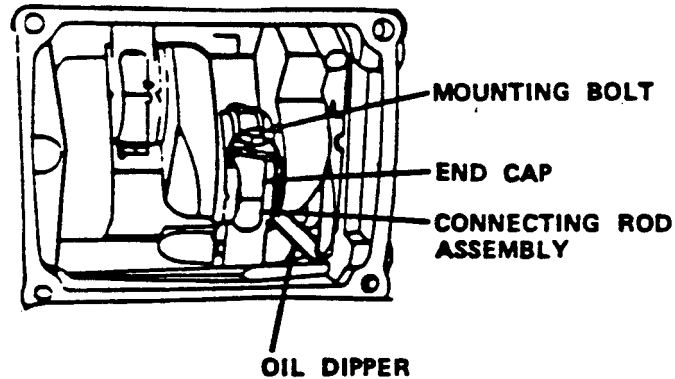
**NOTE**

DO NOT interchange parts when removing pistons, connecting rods or connecting rod caps.

12. Remove two end cap mounting bolts.
13. Pry off end cap.
14. Push piston and connecting rod assembly up through right cylinder assembly and set aside.
15. Repeat steps 11 through 14 for left cylinder assembly.

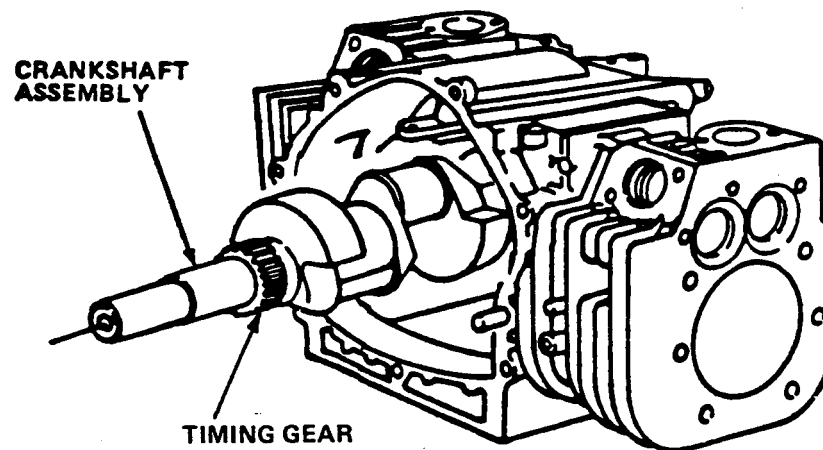

16. Remove timing gear from crankshaft. Remove key from crankshaft.

6-2. CYLINDER BLOCK ASSEMBLY REPAIR (CONT)

17. Remove crankshaft assembly.

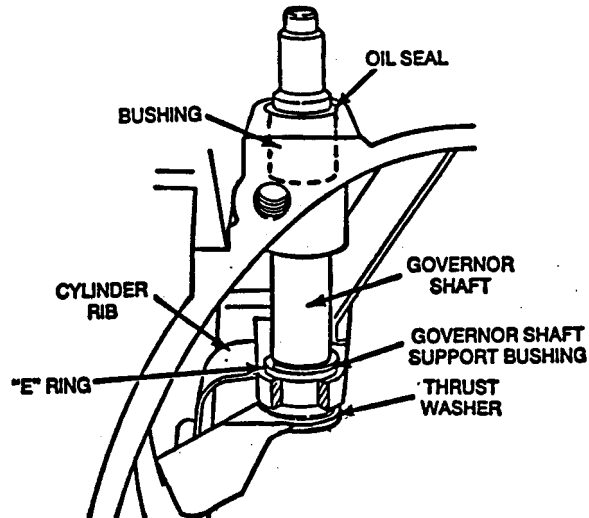

18. Remove governor shaft E-ring and washer. Remove governor shaft assembly.

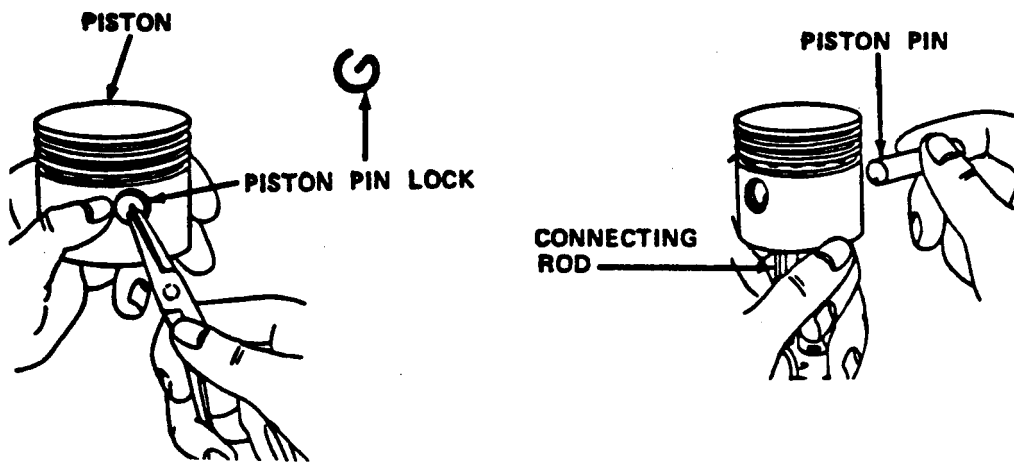

19. Obtain right connecting rod and piston assembly. Remove piston pin lock.

20. Pull out piston pin. Set connecting rod aside.

6-2. CYLINDER BLOCK ASSEMBLY REPAIR (CONT)

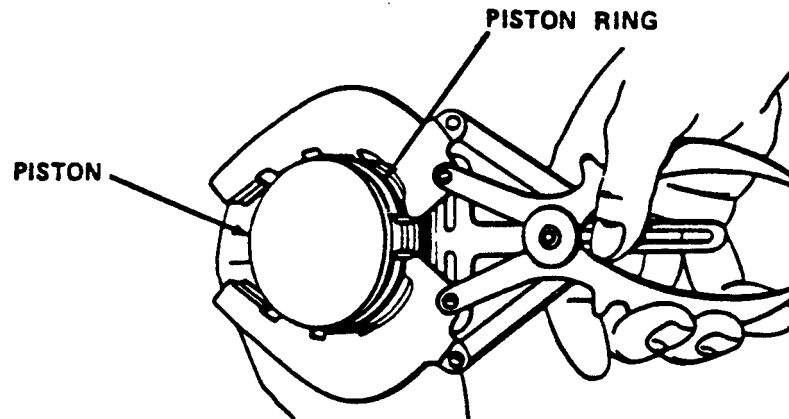

21. Remove second piston pin lock.
22. Remove piston rings one at a time. Set piston aside. Discard piston rings.
23. Repeat steps 19 through 22 for left connecting rod and piston assembly.

SERVICING

1. Visually inspect cylinders for cracked or scored walls.

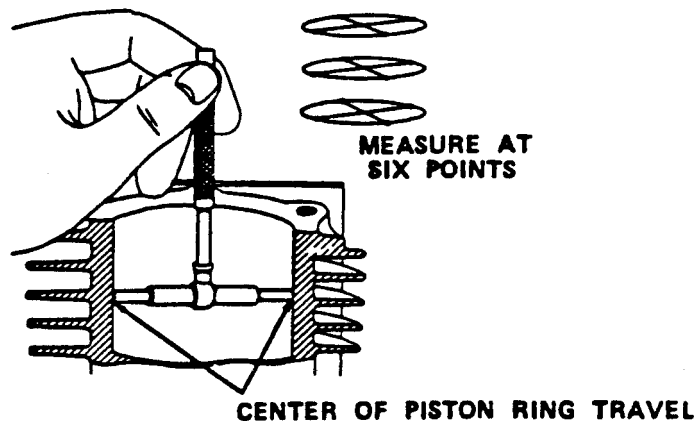
NOTE

If cylinder bore is more than 0.003 in. (0.076 mm) oversize or more than 0.0025 in. (0.064 mm) out of round, cylinder block must be bored to next size.

2. Measure size of cylinder bore. Standard bore size is 3.4375. Resize 0.010, 0.020, 0.030 inch over standard bore.

6-2. CYLINDER BLOCK ASSEMBLY REPAIR (CONT)

WARNING

- Solvent may cause toxic fumes. To prevent personal injury, work only in well-ventilated area. DO NOT breathe fumes for a long time.
 - Solvent is flammable. To prevent fire or explosion, DO NOT bring open flame or sparks near solvent.
3. Using solvent, clean cylinders to remove carbon buildup or foreign matter.
 4. Using solvent, clean carbon buildup from piston and grooves.

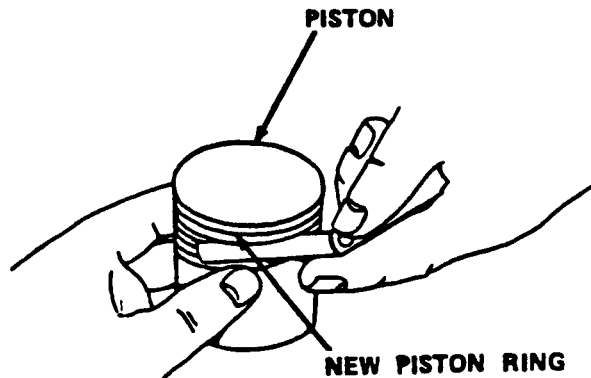

5. Install new piston ring on top ring groove of piston.
6. Check remaining space in groove. If space is 0.007 in. (0.18 mm) or greater, remove piston ring and replace piston.
7. Repeat steps 4 through 6 for left cylinder.

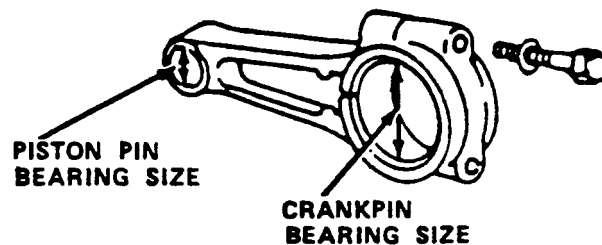

8. Obtain right connecting rod assembly. Check crankpin bearing size. If greater than 1.627 in. (41.33 mm), discard connecting rod assembly.

6-2. CYLINDER BLOCK ASSEMBLY REPAIR (CONT)

9. Check piston pin bearing size. If greater than 0.803 in. (20.40 mm), discard connecting rod assembly.
10. Repeat steps 8 and 9 with left connecting rod.

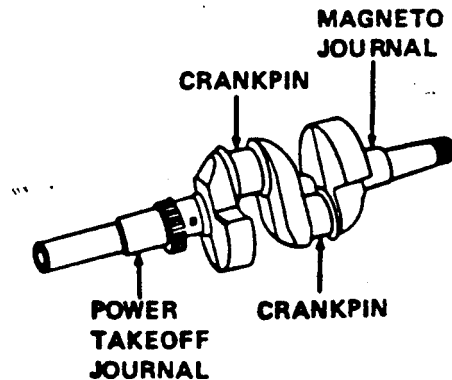

11. Check timing gear (removed in step 16) for broken or missing teeth. Replace if needed.
12. Check crankshaft keyways to make sure they are not worn or spread. If worn or spread so key does not fit, replace crankshaft.
13. Check the following points on the crankshaft: magneto journal, power takeoff journal, and crankpins.
14. Replace crankshaft under any of the following conditions:
 - Power takeoff journal is less than 1.376 in. (34.95 mm).
 - Magneto journal is less than 1.376 in. (34.95 mm).
 - Crankpins are less than 1.622 in. (41.20 mm).

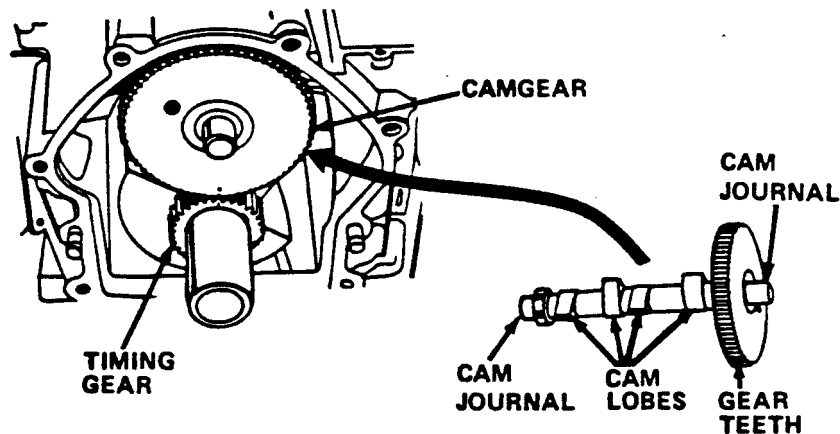

15. Obtain camgear. Check teeth on gear for nicks, wear, or breakage. If teeth are broken, nicked, or badly worn, replace camgear.

6-2. CYLINDER BLOCK ASSEMBLY REPAIR (CONT)

16. Check camgear lobes and cam journals. If camgear lobes are less than 1.124 in. (28.55 mm), replace camgear. If cam journals are less than 0.623 in. (15.82 mm), replace camgear.

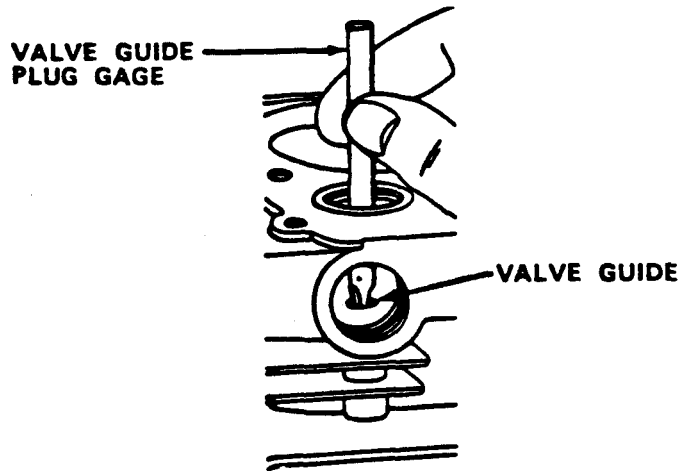

17. Check valve guides with valve guide plug gauge. If valve guide plug gauge can be inserted into the valve guide for a distance of 5/16 in. (8 mm), the guide is worn. Rebush guide by following steps 21 through 24.

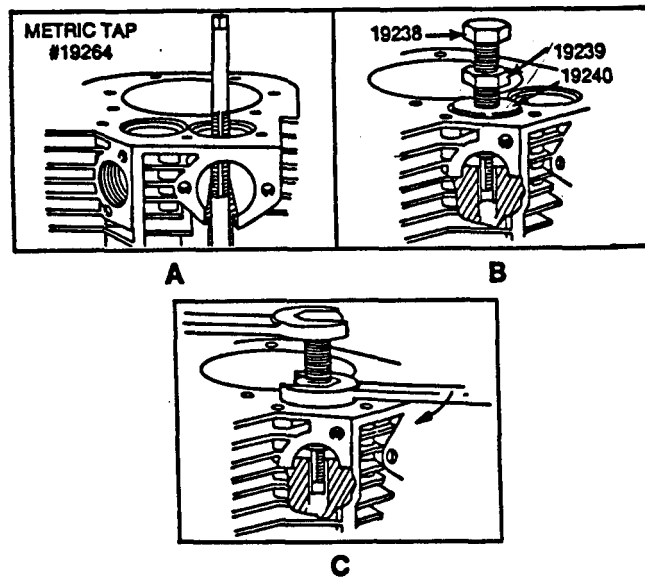

NOTE

Replacement procedures of the exhaust and intake valve guides are the same. Valve guides are NOT interchangeable.

18. Remove valve guide.

6-2. CYLINDER BLOCK ASSEMBLY REPAIR (CONT)

19. Drive in replacement bushing(s) to same depth as original bushing.
20. Ream bushing with bushing guide pilot. Lubricate reamer liberally as necessary with oil. Clean engine of any reaming debris and other foreign matter.

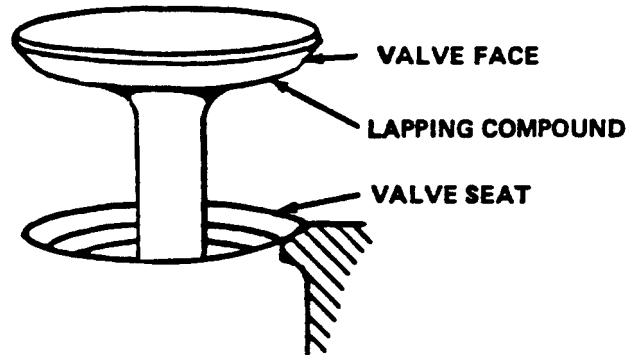

21. Obtain exhaust valves and intake valves.
22. Spread fine lapping compound around all valve faces. Pull valves into valve seats very slowly, one valve at a time. Once each is fully seated, turn it slowly left to right until it makes several complete turns.
23. Push valve out of valve chamber.
24. Inspect valve seat to ensure valve face has seated uniformly in valve seat.
25. If valve or valve seat is worn beyond usable limits or uniform wear pattern is not present, replace valves and valve seats.
26. Remove valve seats.
27. Place crankcase on left cylinder assembly.
28. Install new intake valve seat(s).

NOTE

Make sure chamfered edge of valve seat goes down into cylinder.

29. Using driver, drive new seat until it bottoms. Seat will be slightly below cylinder head gasket surface.

6-2. CYLINDER BLOCK ASSEMBLY REPAIR (CONT)

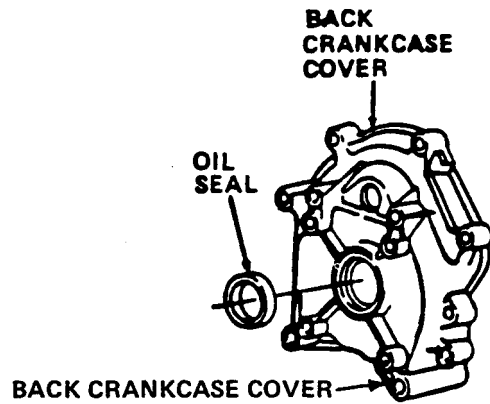

30. Inspect for oil seal damage. Replace if damaged.

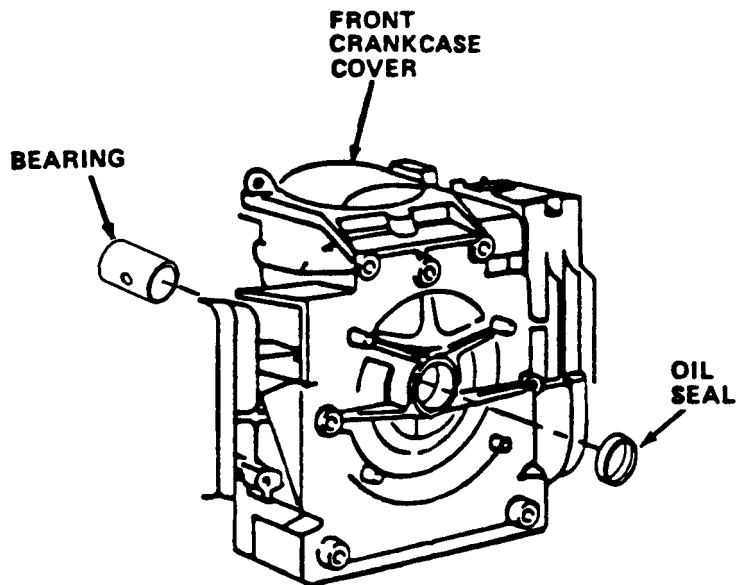

31. Inspect front crankcase oil seal for damage.

32. Inspect crankshaft bearing. Replace as required.

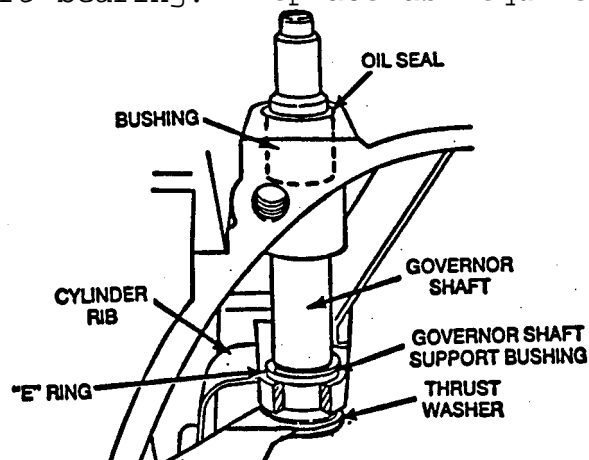

6-2. CYLINDER BLOCK ASSEMBLY REPAIR (CONT)

ASSEMBLY

1. Install governor shaft assembly. Install washer and E-ring on governor shaft.

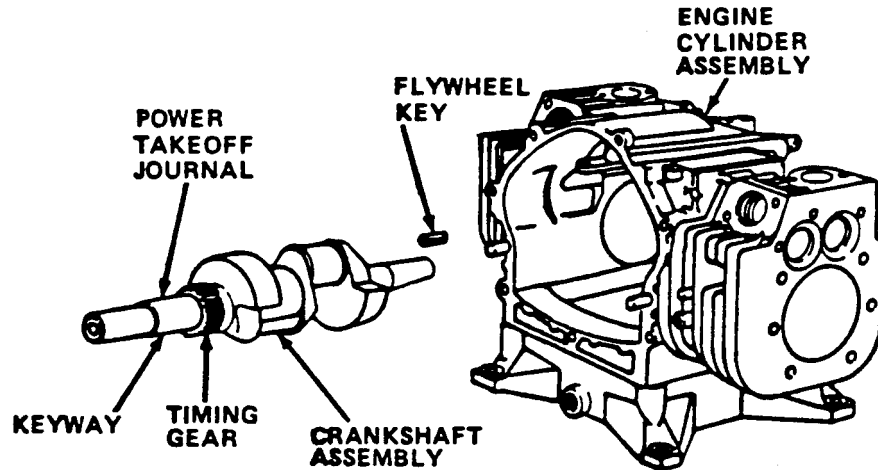

2. Install wood ruff key to power takeoff journal on crankshaft.
3. Slide timing gear onto power takeoff journal.
4. Tap timing gear gently until it fully seats.
5. Install crankshaft in engine cylinder assembly.

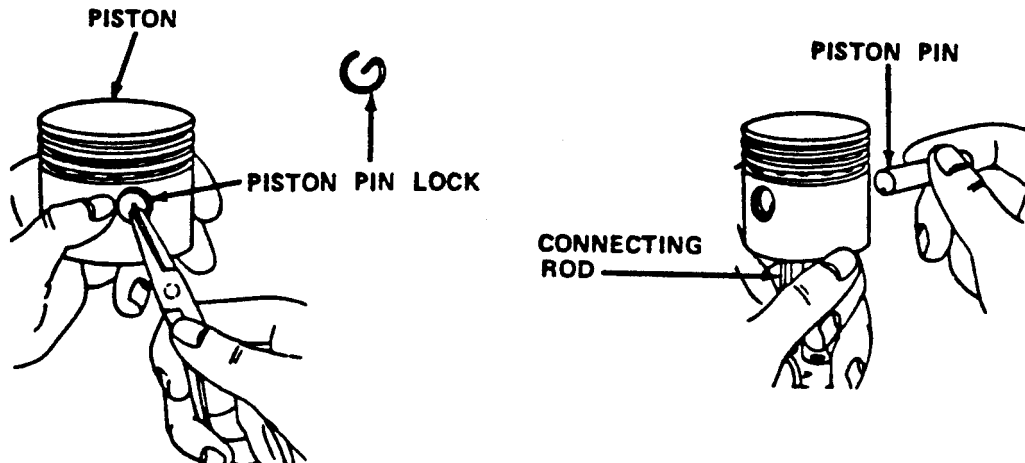

6. Install one piston pin lock in piston assembly.
7. Place connecting rod assemblies up into pistons and make sure piston pin holes are aligned.

6-2. CYLINDER BLOCK ASSEMBLY REPAIR (CONT)

8. Install piston pin through piston and connecting rod assembly.
9. Install remaining piston pin lock in piston assembly.
10. Repeat steps 6 through 9 for other piston.
11. Using engine oil, lubricate piston rings and piston skirts.
12. Install rings on piston. Stagger ring gaps.

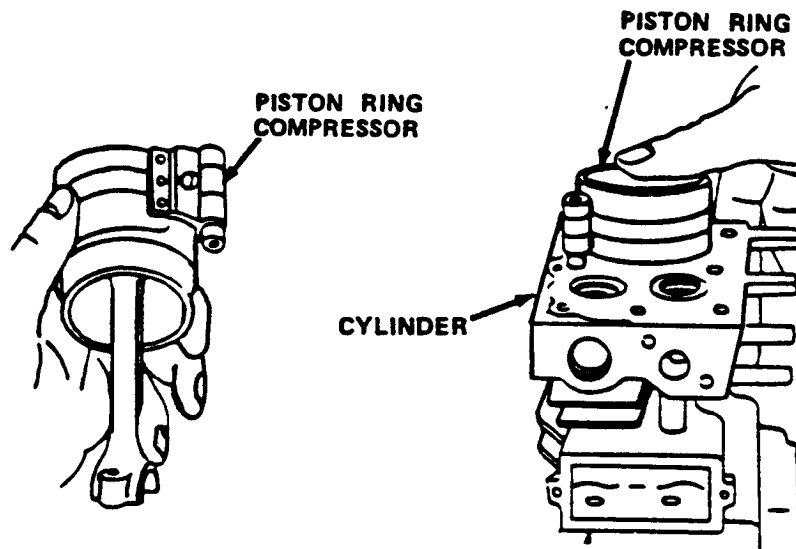

13. Tightly compress piston rings, then loosen compressor very slightly.

CAUTION

To prevent damage to piston rings, DO NOT try to install piston and ring gear assembly without ring compressor.

NOTE

- Notch on top of piston must face flywheel side of cylinder when installed.
- Do not interchange parts.

6-2. CYLINDER BLOCK ASSEMBLY REPAIR (CONT)

14. Push right piston and connecting rod assembly into right cylinder. Make sure oil hole in connecting rod is facing camgear.

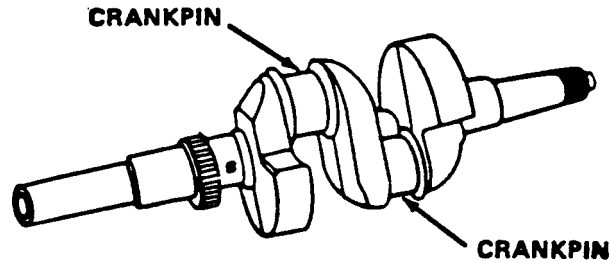

15. Using engine oil, lubricate crankpin.

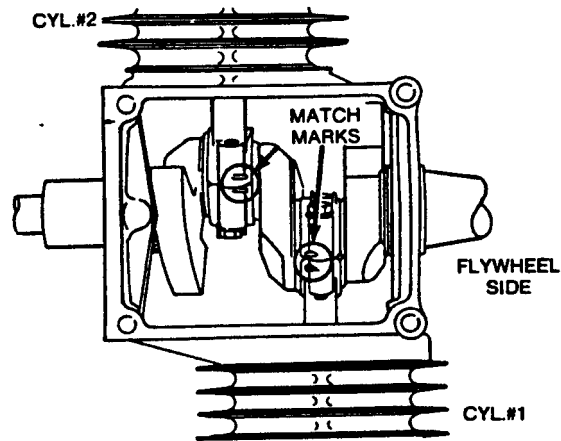

16. Pull connecting rod against crankpin and place end cap with dipper around crankpin. Make sure assembly marks on connecting rod and end cap are aligned.

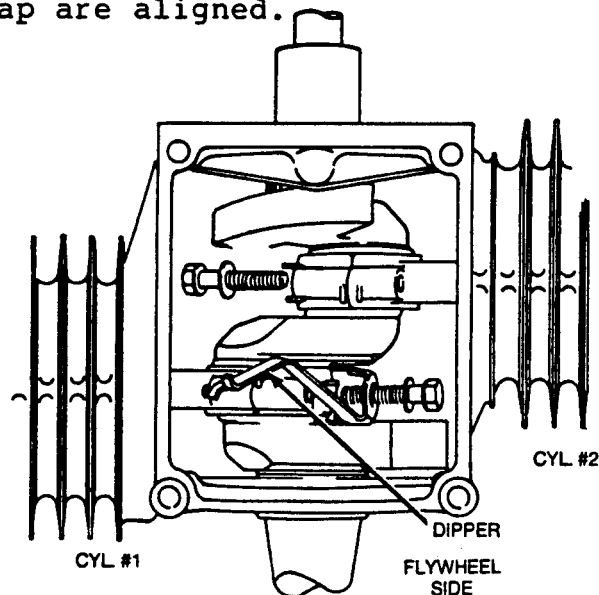

6-2. CYLINDER BLOCK ASSEMBLY REPAIR (CONT)

17. Install end cap mounting bolts and dippers. Torque bolts to 190 in. lb (22 Nm).
18. Rotate crankshaft to allow full entry of second piston and connecting rod assembly.
19. Repeat steps 14 through 18 for left piston.

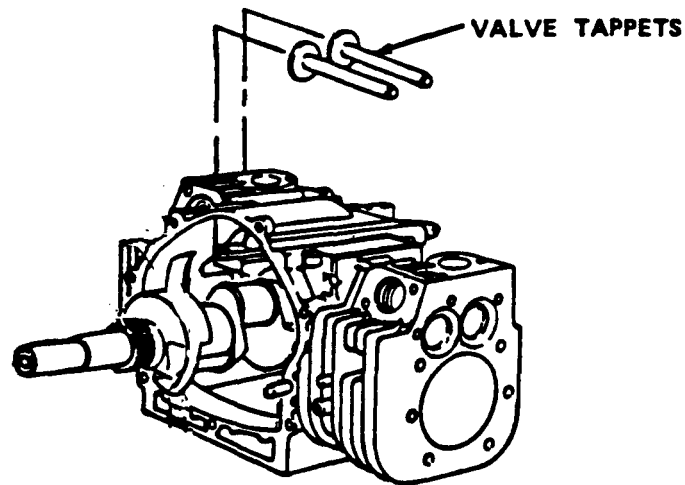

NOTE

Do not interchange parts.

20. Install four valve tappets.

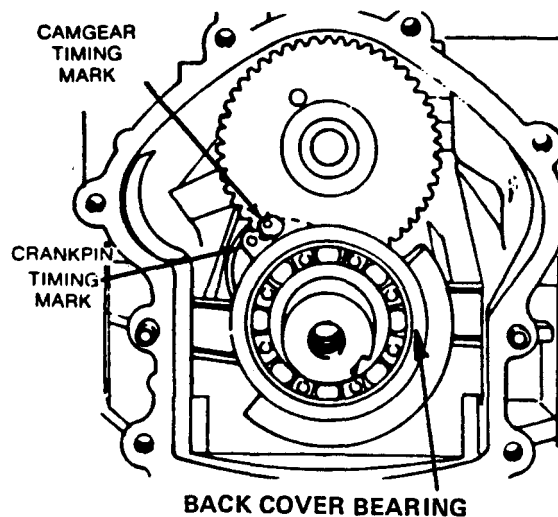

21. Making sure timing marks are aligned, install camgear assembly.

6-2. CYLINDER BLOCK ASSEMBLY REPAIR (CONT)

22. Install back cover bearing.

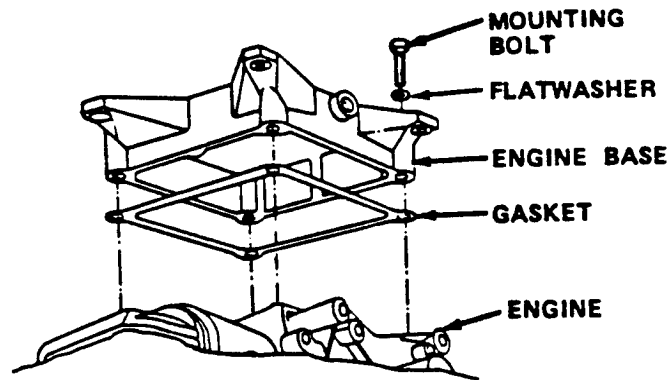

23. With engine cylinder assembly upside down, install engine base gasket and engine base.

CAUTION

To prevent damage to oil seal while assembling crankcase cover, be sure to use oil or grease on sealing edge of oil seal. If sharp edge of oil seal is cut or bent under, seal may leak.

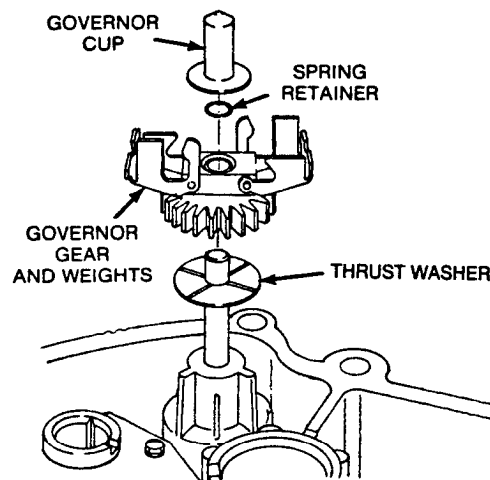

24. Assemble governor gear and thrust washer.

6-2. CYLINDER BLOCK ASSEMBLY REPAIR (CONT)

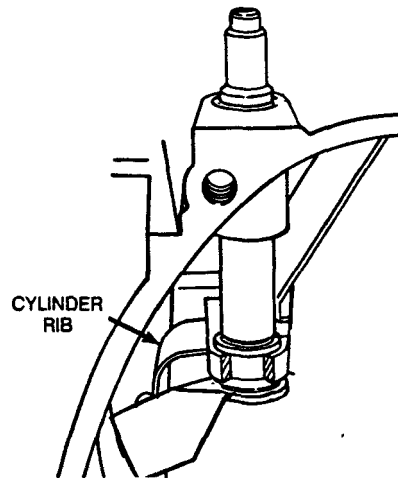

25. Rotate governor shaft clockwise to rib stop.

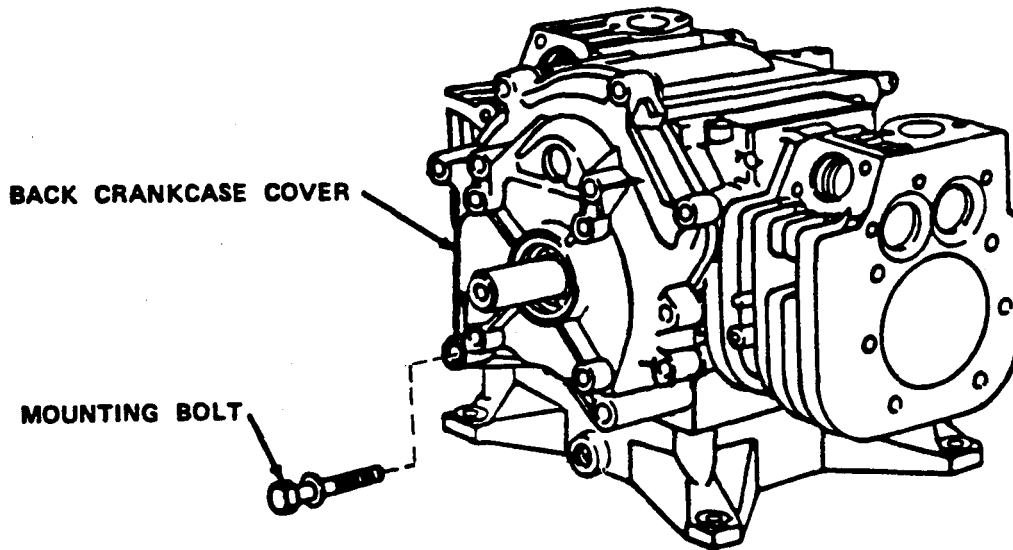

26. Install back crankcase cover and governor gear with mounting bolts.

27. Torque bolts to 225 inch pounds (25.4 Nm).

28. Measure crankshaft end play. End play should be .002 to .008 inches (16 - 30 mm). Using proper gasket(s) obtain proper end play.

6-2. CYLINDER BLOCK ASSEMBLY REPAIR (CONT)

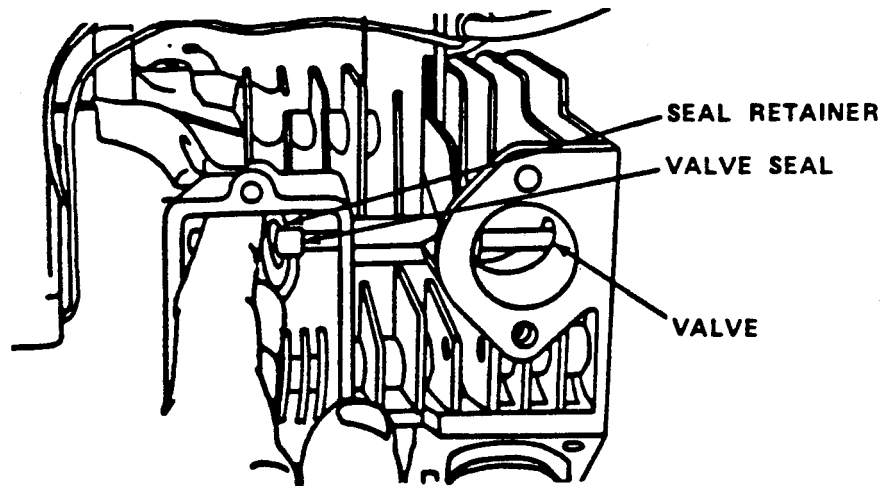

29. Place intake valve seal and seal retainer in valve chamber.
30. Insert intake valve through guide while oiling guide lightly.
31. While rotating valve to prevent damage to seal, push valve slowly through seal and seal retainer.

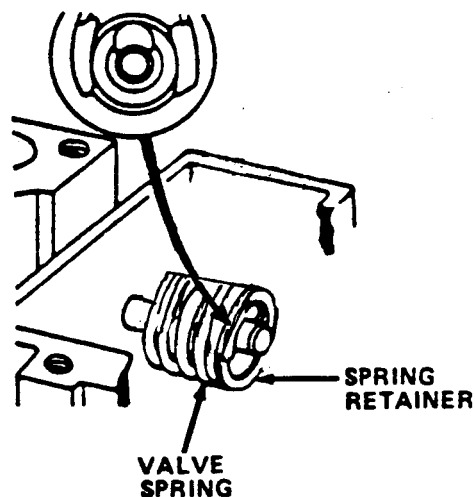

32. Insert spring into valve chamber.
33. Compress spring using valve spring compressor.
34. Slip retainer onto valve and release spring tension. Remove valve spring compressor from valve chamber.

6-2. CYLINDER BLOCK ASSEMBLY REPAIR (CONT)

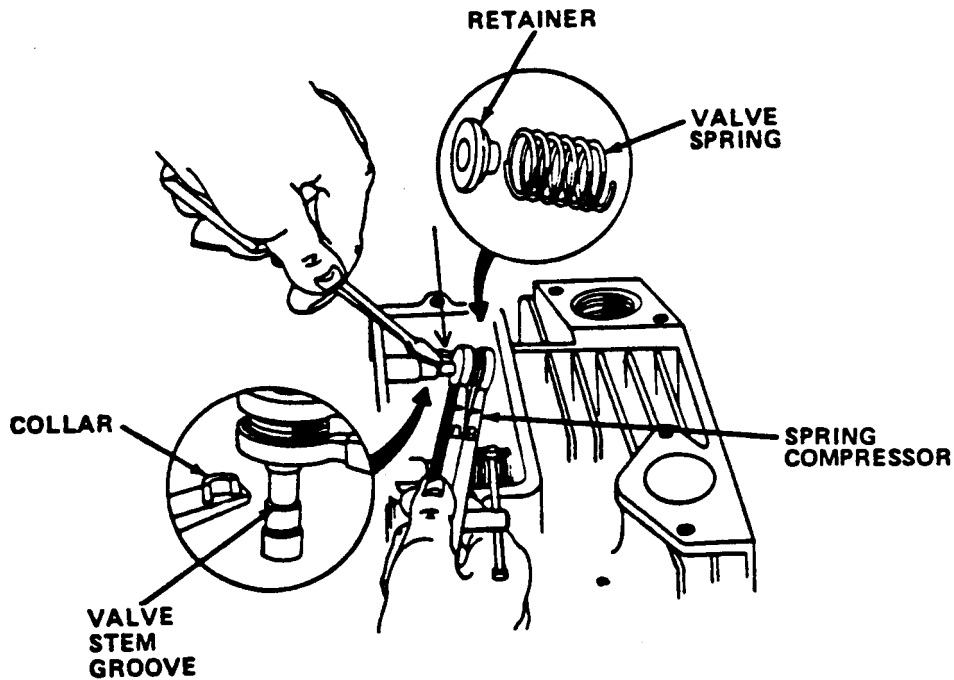

35. Insert exhaust valve spring and retainer into valve chamber.
36. Insert exhaust valve through guide while oiling valve shaft lightly.
37. Insert compressed spring and retainer into valve chamber with valve retainer on back side of chamber.
38. Push exhaust valve through retainer so it is fully seated.
39. Compress valve spring and retainer.
40. Place collars into valve stem groove. Grease may be applied to collars and valve stem for ease in assembly.
41. Repeat steps 29 through 40 for other cylinder.

 6-2. CYLINDER BLOCK ASSEMBLY REPAIR (CONT)

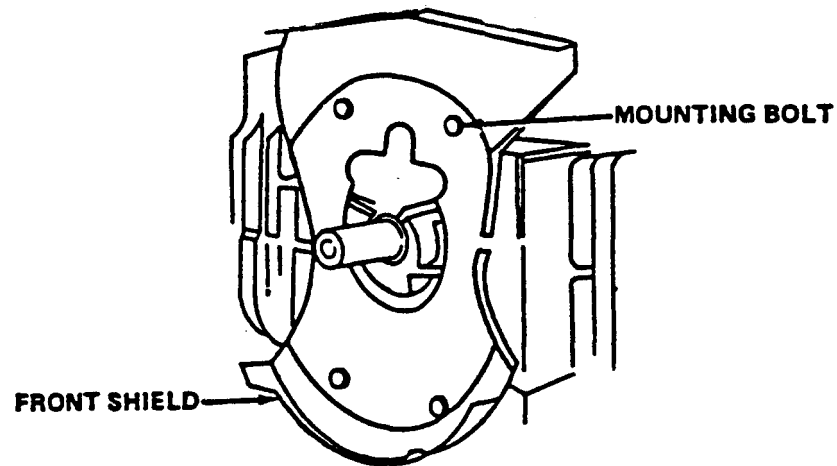

42. Install front cover.

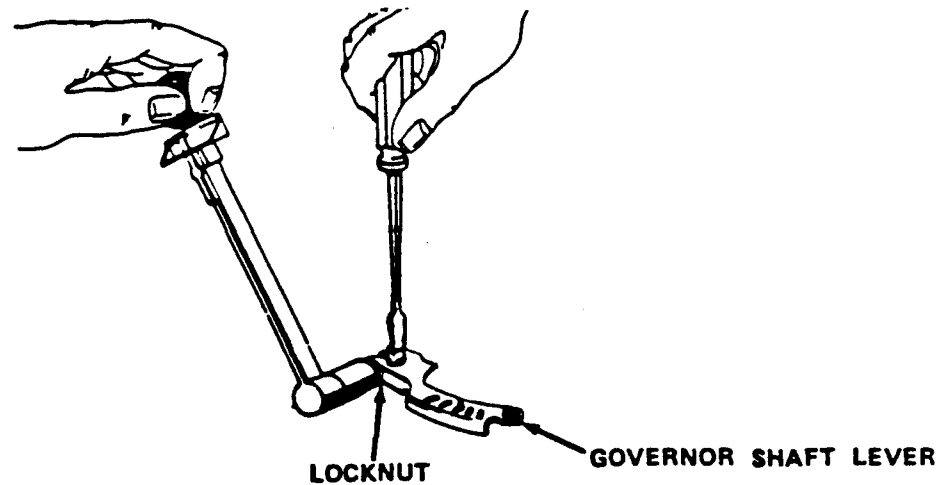

43. Install governor shaft lever.
44. Install governor lever bolt, nut, and washer.
45. Install cylinder head assemblies (para 5-11).
46. Install starter (para 4-33).
47. Install flywheel and ring gear assembly (para 4-34). DO NOT install blower housing.
48. Install armature group (para 4-31). DO NOT install blower housing.
49. Install breather assemblies (para 4-45).

6-2. CYLINDER BLOCK ASSEMBLY REPAIR (CONT)

50. Install dipstick and tube assembly (para 4-32).
51. Install governor assembly (para 4-28, steps 3 through 5).
52. Install carburetor and intake manifold assembly (para 4-27, steps 1 through 6).
53. Connect vacuum line between cylinder block and carburetor.
54. Install centrifugal clutch assembly (para 4-23).
55. Install fan assembly (para 4-22).
56. Install exhaust system (para 4-24).
57. Install engine assembly (para 4-25).
58. Install housing (para 4-15).

**APPENDIX A
REFERENCES**

A-1 . SCOPE . This appendix lists all forms, field manuals, technical manuals, and other publications referenced in this manual.

A-2 . FORMS

Equipment Inspection and Maintenance Worksheet. DA Form 2404
 Quality Deficiency ReportSF 368
 Recommended Changes to Publications and Blank Forms DA Form 2028
 Recommended Changes to Equipment Technical
 Publications.DA Form 2028-2
 Report of DiscrepancySF 364

A-3 . FIELD MANUALS

First Aid for SoldiersFM 21-11

A-4 . TECHNICAL MANUALS

Leak Detector, Refrigerant GasTM 9-4940-435-14
 Operator's Manual for Welding Theory and Application.TM 9-237
 Procedures for Destruction of Equipment to Prevent
 Enemy Use.TM 750-244-3
 Repair Parts and Special Tools ListTM 10-4130-239-24P

A-5 . MISCELLANEOUS PUBLICATIONS

The Army Maintenance Management System (TAMMS).DA Pam 738-750

APPENDIX B
MAINTENANCE ALLOCATION CHART

Section I. INTRODUCTION

B-1. GENERAL

a. This section provides a general explanation of all maintenance and repair functions authorized at various maintenance categories.

b. The Maintenance Allocation Chart (MAC) in Section II designates overall authority and responsibility for the performance of maintenance functions on the identified end item or component.

c. Section III lists the tools and test equipment (both special tools and common tool sets) required for each maintenance function as referenced from Section II.

d. Section IV contains supplemental instructions and explanatory notes for a particular maintenance function.

B-2. MAINTENANCE FUNCTIONS. Maintenance functions will be limited to and defined as follows:

a. Inspect. To determine the serviceability of an item by comparing its physical, mechanical, and/or electrical characteristics with established standards through examination (e.g., by sight, sound, or feel).

b. Test. To verify serviceability by measuring the mechanical, pneumatic, hydraulic, or electrical characteristics of an item and comparing those characteristics with prescribed standards.

c. Service. Operations required periodically to keep an item in proper operating condition, i.e., to clean (includes decontaminate, when required), to preserve, to drain, to paint, or to replenish fuel, lubricants, chemical fluids, or gases.

d. Adjust. To maintain or regulate, within prescribed limits, by bringing into proper or exact position, or by setting the operating characteristics to specified parameters.

e. Align. To adjust specified variable elements of an item to bring about optimum or desired performance.

f. Calibrate. To determine and cause corrections to be made or to be adjusted on instruments or test, measuring, and diagnostic equipments used in precision measurement. Consists of comparisons of two instruments, one of which is a certified standard of known accuracy, to detect and adjust any discrepancy in the accuracy of the instrument being compared.

B-2. MAINTENANCE FUNCTIONS (CONT)

g. Remove/Install. To remove and install the same item when required to perform service or other maintenance functions. Install may be the act of emplacing, seating, or fixing into position a spare, repair part, or module (component or assembly) in a manner to allow the proper functioning of an equipment or system.

h. Replace. To remove an unserviceable item and install a serviceable counterpart in its place. "Replace" is authorized by the MAC and is shown as the third position code of the SMR code.

i. Repair. The application of maintenance services¹, including fault location/troubleshooting², removal/installation, and disassembly/assembly³ procedures, and maintenance actions to identify troubles and restore serviceability to an item by correcting specific damage, fault, malfunction, or failure in a part, subassembly, module (component or assembly), end item, or system.

j. Overhaul. That maintenance effort (service/action) necessary for the restoration of unserviceable equipment to a like new condition in accordance with original manufacturing standards. Rebuild is the highest degree of material maintenance applied to Army equipment. The rebuild operation includes the act of returning to zero those age measurements (hours/miles, etc.) considered in classifying Army equipment/components.

k. Rebuild. Consists of those services/actions necessary for the restoration of unserviceable equipment to a like new condition in accordance with original manufacturing standards. Rebuild is the highest degree of maintenance performed by the Army. The rebuild operation includes the act of returning to zero those age measurements (hours/miles, etc.) considered in classifying Army equipment/components.

¹Services - inspect, test, service, adjust, align, calibrate, and/or replace.

²Fault locate/troubleshoot - the process of investigating and detecting the cause of equipment malfunctioning; the act of isolating a fault within a system or unit under test (UUT).

³Disassemble/assemble - encompasses the step-by-step taking apart (or breakdown) of a spare/functional group coded item to the level of its least component identified as maintenance significant (i.e., assigned an SMR code) for the category of maintenance under consideration.

⁴Actions - welding, grinding, riveting, straightening, facing, remachinery, and/or resurfacing.

B-3 . EXPLANATION OF COLUMNS IN THE MAC, SECTION II

a. Column 1, Group Number. Column 1 lists functional group code numbers, the purpose of which is to identify maintenance significant components, assemblies, subassemblies, and modules with the next higher assembly. End item group number shall be "00".

b. Column 2, Component/Assembly. Column 2 contains the names of components, assemblies, subassemblies, and modules for which maintenance is authorized.

c. Column 3, Maintenance Function. Column 3 lists the functions to be performed on the item listed in column 2. (For detailed explanation of these functions, see paragraph B-2.)

d. Column 4, Maintenance Category. Column 4 specifies, by listing of a work time figure in the appropriate subcolumn(s), the category of maintenance authorized to perform the function listed in column 3. This figure represents the active time required to perform that maintenance function to the indicated category of maintenance. If the number or complexity of the tasks within the listed maintenance function vary at different maintenance categories, appropriate work time figures will be shown for each category. The work time figure represents the average time required to restore an item (assembly, subassembly, component, module, end item, or system) to a serviceable condition under typical field operating conditions. This time includes preparation time (including any necessary disassembly/assembly time), troubleshooting/fault location time, and quality assurance/quality control time in addition to the time required to perform the specific task identified for the maintenance functions authorized in the maintenance allocation chart. The symbol designations for various maintenance categories are as follows:

- COperator or crew
- OUnit maintenance
- FDirect support maintenance
- HGeneral support maintenance
- LSpecialized repair activity (SRA)⁵
- DDepot maintenance

⁵This maintenance category is not included in Section II, column (4) of the maintenance allocation chart. To identify functions to this category of maintenance, enter a work time figure in the "H" column of Section II, column (4) , and use an associated reference code in the Remarks column (6). Key the code to Section IV, Remarks, and explain the SRA complete repair application there. The explanatory remark(s) shall reference the specific repair parts and special tools list (RPSTL) TM which contains additional SRA criteria and the authorized spare/repair parts.

B-3 . EXPLANATION OF COLUMNS IN THE MAC, SECTION II (CONT)

e. Column 5, Tools and Equipment. Column 5 specifies, by code, those common tool sets (not individual tools) and special tools, TMDE, and support equipment required to perform the designated function.

f. Column 6, Remarks. This column shall, when applicable, contain a letter code, in alphabetic order, which shall be keyed to the remarks contained in Section IV.

B-4 . EXPLANATION OF COLUMNS IN TOOL AND TEST EQUIPMENT REQUIREMENTS, SECTION III

a. Column 1, Reference Code. The tool and test equipment reference code correlates with a code used in the MAC, Section II, column 5.

b. Column 2, Maintenance Category. The lowest category of maintenance authorized to use the tool or test equipment.

c. Column 3, Nomenclature. Name or identification of the tool or test equipment.

d. Column 4, National Stock Number. The national stock number of the tool or test equipment.

e. Column 5, Tool Number. The manufacturer's part number.

B-5 . EXPLANATION OF COLUMNS IN REMARKS, SECTION IV

a. Column 1, Reference Code. The code recorded in column 6, Section II.

b. Column 2, Remarks. This column lists information pertinent to the maintenance function being performed as indicated in the MAC, Section II.

Section II. MAINTENANCE ALLOCATION CHART
FOR
SMALL MOBILE WATER CHILLER

(1) GROUP NUMBER	(2) COMPONENT ASSEMBLY	(3) MAINTENANCE FUNC- TION	(4) MAINTENANCE CATEGORY					(5) TOOLS AND EQUIP.	(6) REMARKS
			UNIT		DS	GS	DEPOI		
			C	O	F	H	D		
00	Small Mobile Water Chiller Assembly								
01	Housing Assembly	Inspect Replace Repair	0.1 0.2	2.0				1,3,10 A	
02	Electrical System								
0201	Wiring Harness Assembly	Inspect Test Repair	0.2	1.0 2.0				2 1 A	
0202	Toggle Switch	Inspect Test Replace	0.1	0.2 2.0				2 1 A	
0203	Pneumatic Timer	Inspect Test Replace	0.1	0.2 0.3				2 1 A	
03	Drive System								
0301	Water Pump Drivebelt	Inspect Adjust Replace	0.2	0.5 1.0				1 1 A	
0302	Compressor Drivebelt	Inspect Adjust Replace	0.2	0.5 1.0				1 1 A	
0303	Fan Assembly	Inspect Replace	0.2	1.0				1 A	
0304	Centrifugal Clutch Drive	Inspect Replace	0.2	0.5 2.0				1,3 A	

Section II. MAINTENANCE ALLOCATION CHART
FOR
SMALL MOBILE WATER CHILLER (CONT)

(1) GROUP NUMBER	(2) COMPONENT ASSEMBLY	(3) MAINTENANCE FUNC- TION	(4) MAINTENANCE CATEGORY					(5) TOOLS AND EQUIP .	(6) REMARKS
			UNIT		DS F	GS H	DEPOT D		
			C	U					
04	Exhaust System	Inspect	0.2						
		Replace		0.5				1	A
05	Gasoline Engine Assembly	Inspect		0.5					
		Test		1.0				2	C
		Replace		2.0				1	A
0501	Air Cleaner Cartridge and Pre- cleaner	Inspect	0.1						
		Service Replace	0.5	0.3					A
0502	Carburetor and Intake Manifold Assembly	Inspect		0.2					
		Replace		1.0				1	A
0503	Governor Control	Inspect	0.2	0.3					
		Adjust		0.7				1	
		Replace		1.0				1,2	A
0504	Starter Panel Assembly	Test		0.7				2	
		Replace		1.0				1	A
0505	Starter Motor Assembly	Inspect		0.7					
		Test		0.3				2	
		Replace		1.0				1	A
0506	Flywheel and Ring Gear Assembly	Inspect		0.7				1	
		Replace		2.0				2,9	A
0507	Breather Assemblies	Inspect		0.1				1	
		Replace		0.5				1	A
0508	Dipstick and Tube Assem- bly	Inspect	0.1						
		Replace		1.0				1	A

Section II. MAINTENANCE ALLOCATION CHART
 FOR
 SMALL MOBILE WATER CHILLER (CONT)

(1) GROUP NUMBER	(2) COMPONENT ASSEMBLY	(3) MAINTENANCE FUNC- TION	(4) MAINTENANCE CATEGORY					(5) TOOLS AND EQUIP .	(6) REMARKS
			UNIT		DS F	GS H	DEPOT D		
			C	U					
0509	Spark Plug	Test Adjust Replace		0.2 0.1 0.2				1 1 1	A
0510	Armature Group	Inspect Test Adjust Replace		0.7 1.5 1.5 1.5				1 1 1 1	A
0511	Cylinder Heads	Inspect Replace			0.7 2.0			1,3	
0512	Cylinder Block Assembly	Inspect Replace Repair			1.0 5.0 5.5	12.0		1 1,2,6	B
06	Water System	Test			3.0			1,3	
0601	Water Pump Assembly	Inspect Replace		0.7 1.5				1	A
0602	High Tem- perature Thermal Switch	Inspect Test Replace		0.5 1.5 3.0				2 2	A
0603	Evaporator	Inspect Replace		0.3	6.0			3,5	
0604	Relief Valve	Adjust Replace		0.5	3.0			1 1,3,10	
0605	Heat Ex- changer	Inspect Replace			0.3 4.0			4 3,5	
0606	Thermostatic Valve	Inspect Replace Repair		1.0	4.0 5.0			1 1,3 1	

Section II. MAINTENANCE ALLOCATION CHART
FOR
SMALL MOBILE WATER CHILLER (CONT)

(1) GROUP NUMBER	(2) COMPONENT ASSEMBLY	(3) MAINTENANCE FUNC- TION	(4) MAINTENANCE CATEGORY					(5) TOOLS AND EQUIP.	(6) REMARKS
			UNIT		DS	GS	DEPOT		
			C	U	F	H	D		
0607	Start-Run Valve Assembly	Inspect Replace	0.1		4.0			3,5	
0608	Low Tem- perature Thermal Switch	Inspect Test Replace		1.7 1.5	3.0			2 1,3,10	
07	Refrigera- tion System	Inspect Test Service Repair	0.4		4.0 6.0 6.2			5 5 5 5	
0701	Pressure Switch Assemblies	Inspect Test Replace	0.1	0.3	3.0			2 5	
0702	Refrigerant Hose Assem- blies	Inspect Replace	0.1		3.0			3,5	
0703	Expansion Valve	Inspect Test Replace		0.1	1.0 3.0			5 3,5	
0704	Filter- Drier	Inspect Replace		0.1	3.0			3,5	
0705	Condenser Assembly	Inspect Service Replace	0.1	0.1 0.5	5.0			5	
0706	Pressure Relief Valve	Inspect Replace		0.1	3.0			5	

Section II. MAINTENANCE ALLOCATION CHART
 FOR
 SMALL MOBILE WATER CHILLER (CONT)

(1) GROUP NUMBER	(2) COMPONENT ASSEMBLY	(3) MAINTENANCE FUNC- TION	(4) MAINTENANCE CATEGORY					(5) TOOLS AND EQUIP.	(6) REMARKS	
			UNIT		DS	GS	DEPOT			
			C	U	F	H	D			
0707	Compressor Assembly	Inspect Replace		0.7		4.0			5	
0708	Compressor, Pulley Assembly	Inspect Replace		0.4		5.5			5	
08	Skid Assembly									
0801	Starter Con- nection Assembly	Test Replace		0.5 1.0					2 1,3	A
0802	Carrying Handles	Inspect Replace	0.1	1.0					1	A
0803	Skid	Inspect Replace Repair	0.7	1.0		8.0			1,3,10 1	A
09	Trailer Mounting Kit	Inspect Install	0.2			2.0			1	
10	Support Kit									
1001	Hose, Fuel	Inspect Repair	0.1	0.7					1	A
1002	Hose, Water	Inspect Repair	0.1	0.7					1	A

Section III. TOOL AND TEST EQUIPMENT REQUIREMENTS
FOR
SMALL MOBILE WATER CHILLER

(1) TOOL/TEST EQUIP. REF CODE	(2) MAINTENANCE CATE- GORY	(3) NOMENCLATURE	(4) NATIONAL/ NATO STOCK NUMBER	(5) TOGL NUM- BER
1	O	Tool Kit, General Mechanic's Automotive	5180-00-177-7033	
2	O	Shop Equipment, Auto- motive Maintenance and Repair: Organizational Maintenance Common No. 1	4910-00-754-0654	
3	F,H	Shop Equipment, Automotive Maintenance and Repair: Field Maintenance, Basic	4910-00-754-0705	
4	F	Dry Nitrogen Regulator	4820-00-922-0085	
5	F	Tool Kit, Service, Refrigeration Unit	5180-00-596-1474	
6	H	Shop Equipment, Automotive Maintenance and Repair: Field Maintenance, Basic Supplement No. 2	4910-00-754-0707	
7	F	Vacuum Pump	4310-00-289-5967	
8	O	Tachometer, Mechanical, Hand Held	6680-00-171-4584	
9	O	Flywheel Holder Tool, P/N 19321 Cage: 08645		
10	O	Riveter, Blind, Hand	5120-00-017-2849	
11	H	Valve Guide Tool Kit, P/N 19232 Cage: 08645		
12	H	Valve Guide Plug Gauge, P/N 19151 Cage: 08645		
13	O	Valve Seat Puller Kit, P/N 19232 Cage: 08645		
14	F-H	Recovery and Recycling Unit, Refrigerant	4130-01-338-2707	17500B (07295)

Section IV. REMARKS

REFERENCE CODE	REMARKS
A	All repair and replacement of parts performed by unit maintenance limited to authorized items listed in TM 10-4130-239-24P.
B	At Direct Support, repair of engine assembly is limited to replacement of engine base, cylinder heads and gaskets.
C	Perform compression test.

APPENDIX C
COMPONENTS OF END ITEM AND BASIC ISSUE ITEMS LISTS

Section I. INTRODUCTION

C-1. SCOPE . This appendix lists components of end item and basic issue items for the Small Mobile Water Chiller to help you inventory items required for safe and efficient operation.

C-2 . GENERAL . The Components of End Item and Basic Issue Items Lists are divided into the following sections:

a. Section II. Components of End Item. This listing is for informational purposes only, and is not authority to requisition replacements. These items-are part of the end item, but are removed and separately packaged for transportation or shipment. As part of the end item, these items must be with the end item whenever it is issued or transferred between property accounts. Illustrations are furnished to assist you in identifying the items.

b. Section III. Basic Issue Items. These are the minimum essential items required to place the Small Mobile Water Chiller in operation, to operate it, and to perform emergency repairs. Although separately packaged, basic issue items (BII) must be with the Small Mobile Water Chiller during operation and whenever it is transferred between property accounts. The illustrations will assist you in hard-to-identify items. This manual is your authority to request/requisition replacement BII, based on TOE/MTOE authorization of the end item.

C-3. EXPLANATION OF COLUMNS. The following provides an explanation of columns found in the tabular listings:

a. Column (1) - Illustration Number (Illus Number). This column indicates the number of the illustration in which the item is shown.

b. Column (2) - National Stock Number. Indicates the National stock number assigned to the item and will be used for requisitioning purposes.

c. Column (3) - Description. Indicates the Federal item name and, if required, a minimum description to identify and locate the item. The last line for each item indicates the FSCM (in parentheses) followed by the part number.

C-3 . EXPLANATION OF COLUMNS (CONT)

d. Column (4) - Unit of Measure (U/M). Indicates the measure used in performing the actual operational/maintenance function. This measure is expressed by a two-character alphabetical abbreviation (e.g., ea, in., pr).

e. Column (5) - Quantity Required (Qty Rqr). Indicates the quantity of the item authorized to be used with/on the equipment.

Section II. COMPONENTS OF END ITEM

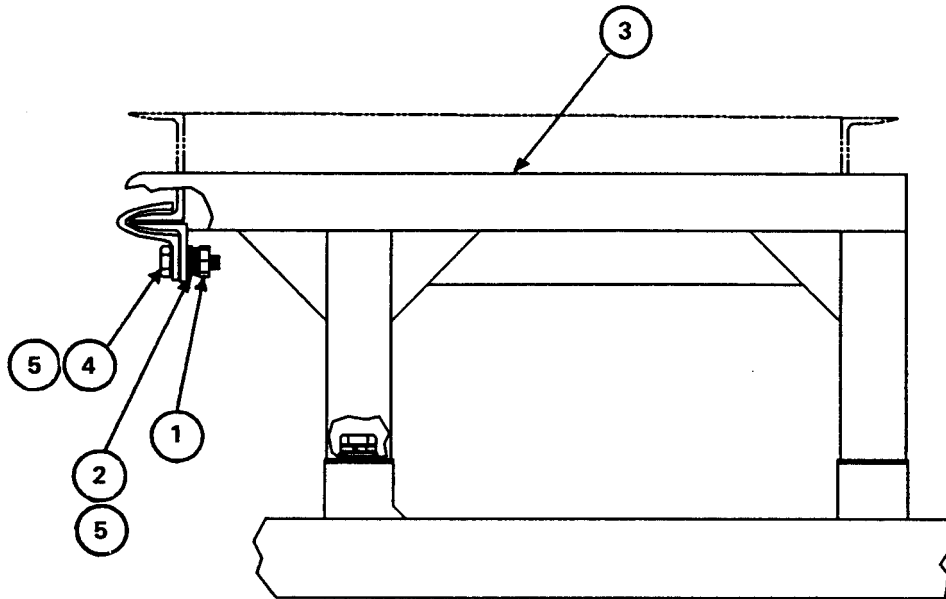

(1) Illus Number	(2) National Stock Number	(3) Description FSCM and Part Number	(4) U/M	(5) Qty Rqr
		MOUNTING KIT, TRAILER (97403) 13226E1712 Consists of the following:	EA	1
1		NUT, PLAIN, HEXAGON MS35649-2382	EA	2
2		WASHER, LOCK-SPRING MS35338-141	EA	2
3		CRADLE, WATER CHILLER (97403) 13226E1727	EA	2
4		SCREW, CAP, HEXAGON MS35307-361	EA	2
5		FLATWASHER MS15759-814	EA	4

Section II. COMPONENTS OF END ITEM (CONT)

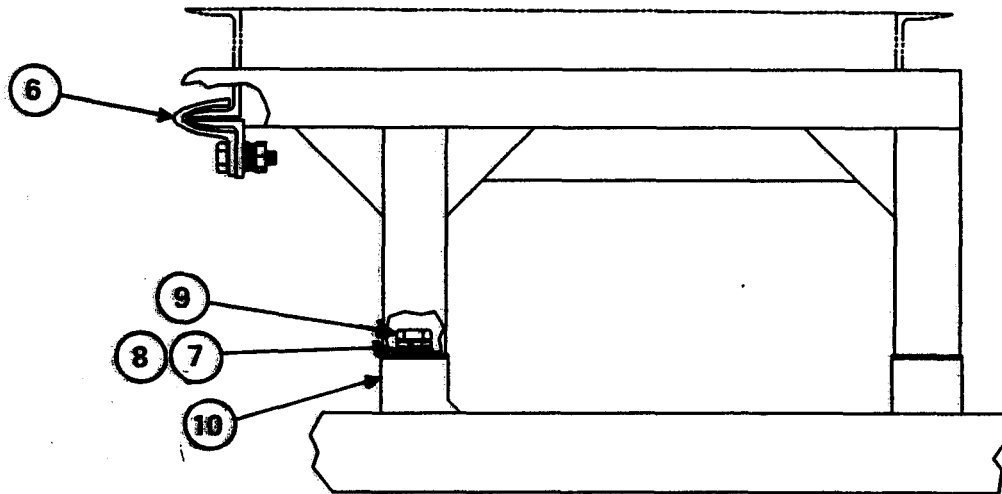

(1) Illus Number	(2) National Stock Number	(3) Description FSCM and Part Number	(4) U/M	(5) Qty Rqr
6		HOOK, GRAB (97403) 13226E1719	EA	2
7		WASHER, LOCK-SPRING MS35338-143	EA	4
8		WASHER, FLAT MS15795-818	EA	4
9		SCREW, HEX HEAD MS35307-411	EA	4
10		BLOCK, MOUNTING CRADLE (97403) 13226E1836	EA	4

Section II. COMPONENTS OF END ITEM (CONT)

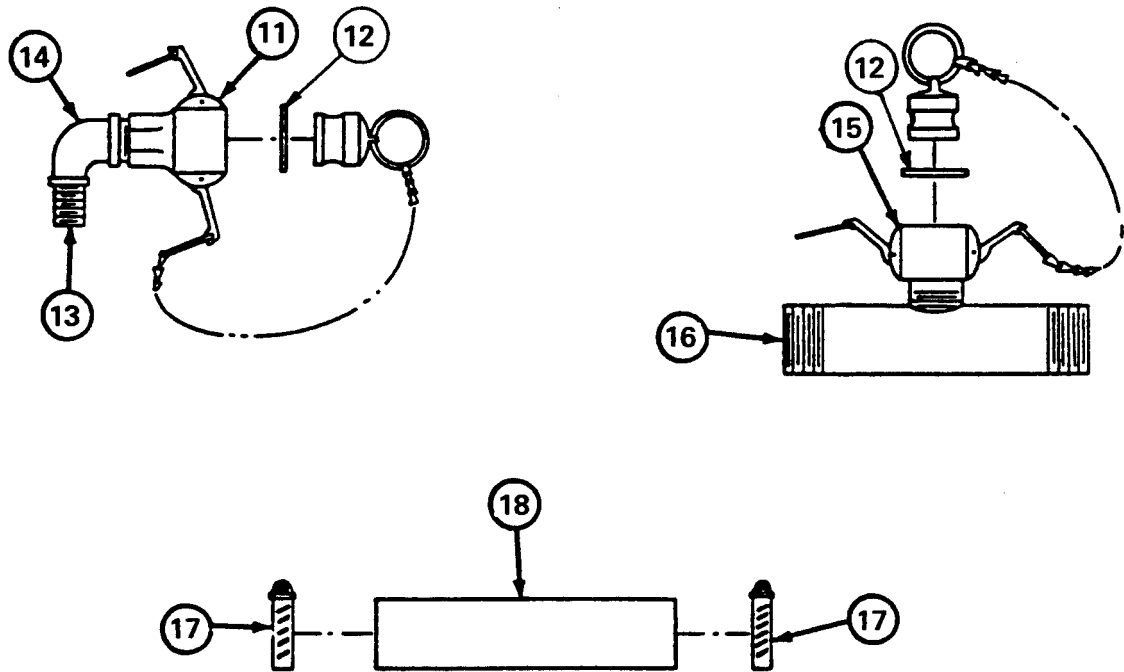

(1) Illus Number	(2) National Stock Number	(3) Description FSCM and Part Number	(4) U/M	(5) Qty Rqr
11		COUPLING HALF, FEMALE MS27026-3	EA	2
12		GASKET, COUPLING (97403) 13226E/1824-2	EA	2
13		NIPPLE, REDUCER, BRASS, HEX SAE J530, PN 130137	EA	1
14		ELBOW, BRASS, REDUCING, 90° MS14308-4	EA	1
15		COUPLING HALF, QUICK DISCONNECT, FEMALE MS27026-3	EA	1
16		NIPPLE (9403) 13226E1819	EA	1
17		CLAMP, HOSE MS35842-11	EA	2
18		HOSE, RUBBER (9403) 13226E1820	EA	1

Section II. COMPONENTS OF END ITEM (CONT)

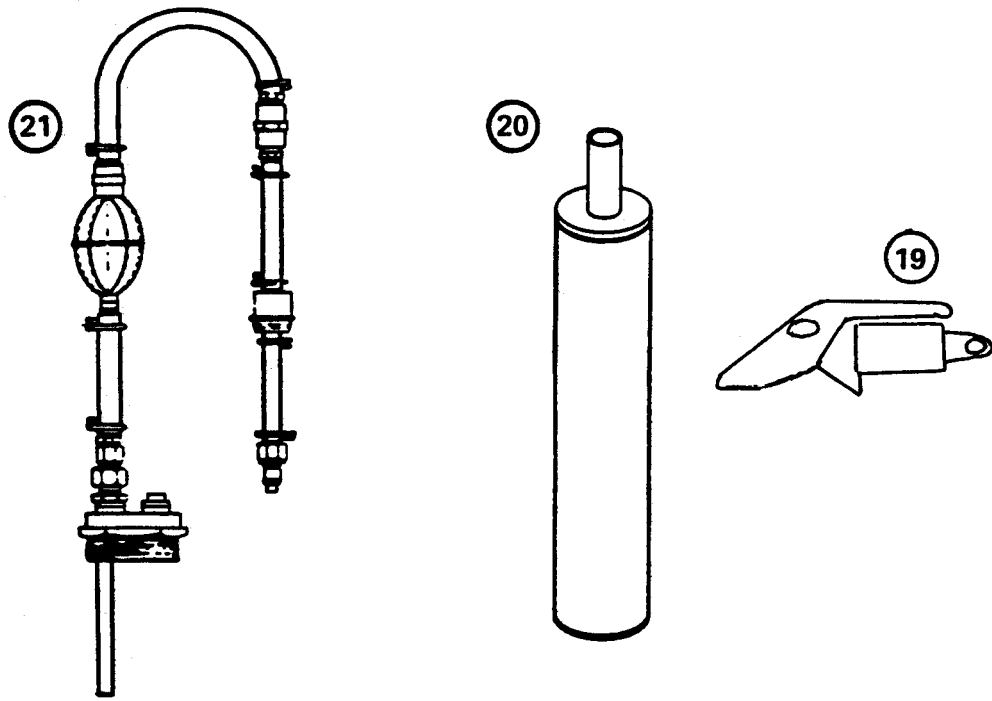

(1) Illus Number	(2) National Stock Number	(3) Description FSCM and Part Number	(4) U/M	(5) Qty Rqr
		SUPPORT KIT, WATER CHILLER (97403) 13226E1790 Consists of the following:		
19		CAP, MUFFLER (97403) 13226E1825	EA	1
20		MUFFLER (97403) 13226E1733	EA	1
21		LINE, FUEL ASSEMBLY (97403) 13226E1714	EA	1

Section II. COMPONENTS OF END ITEM (CONT)

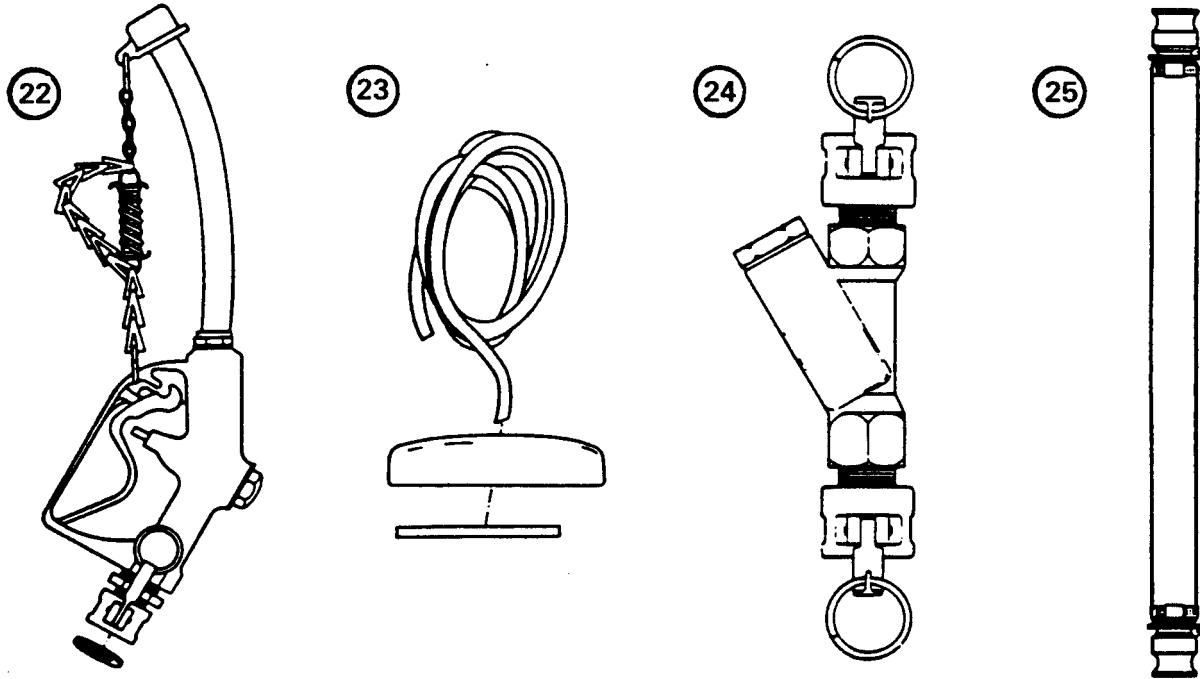

(1) Illus Number	(2) National Stock Number	(3) Description FSCM and Part Number	(4) U/M	(5) Qty Rqr
22		NOZZLE ASSEMBLY (97403) 13226E1787	EA	1
23		ROPE, STARTER (97403) 13226E1796	EA	1
24		STRAINER ASSEMBLY (97403) 13226E1738		
25		TUBE ASSEMBLY (97403) 13226E1710	EA	5

Section III. BASIC ISSUE ITEMS

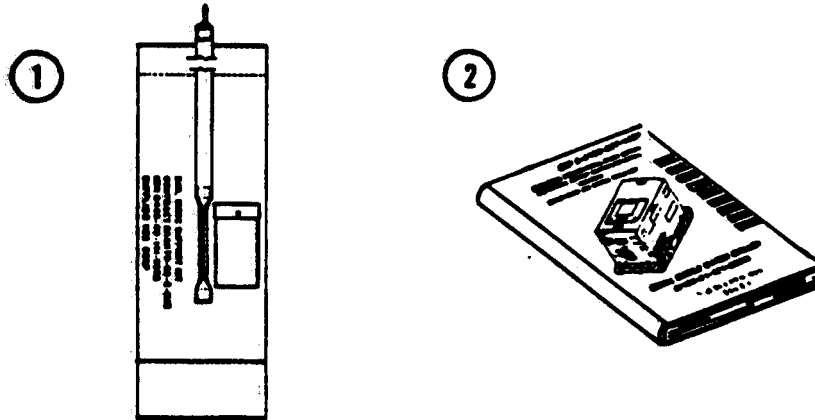

(1) Illus Number	(2) National Stock Number	(3) Description FSCM and Part Number	(4) U/M	(5) Qty Rqr
1	8465-00-141-0932	BAG, DUFFLE (97403) 13226E1802	EA	1
2		MANUAL, OPERATOR'S, UNIT, DIRECT SUPPORT AND GENERAL SUPPORT MAINTENANCE SMALL MOBILE WATER CHILLER, TM 10-4130-239-14	EA	1

APPENDIX D
 ADDITIONAL AUTHORIZATION LIST

Section I. INTRODUCTION

D-1 . **SCOPE** . This appendix lists additional items you are authorized for the support of the Small Mobile Water Chiller.

D-2 . **GENERAL** . This list identifies items that do not have to accompany the Small Mobile Water Chiller and that do not have to be turned in with it. These items are all authorized to you by CTA, MTOE, TDA, or JTA.

D-3 . **EXPLANATION OF LISTING**. National stock numbers, descriptions, and quantities are provided to help you identify and request the additional items you require to support this equipment. The items are listed in alphabetical sequence by item name under the type document (i.e., CTA, MTOE, TDA, or JTA) which authorizes the item to you .

Section II. ADDITIONAL AUTHORIZATION LIST

(1) National Stock Number	(2) Description FSCM and Part Number	(3) U/M	(4) Qty Rqr
4910-00-387-9592	PADDLE, WOODEN	EA	1
	PAIL, UTILITY, 5-GALLON	EA	4
	PAN, DRAIN, 4-GALLON	EA	1
	THERMOMETER	EA	1

APPENDIX E
EXPENDABLE/DURABLE SUPPLIES AND MATERIALS LIST

Section I. INTRODUCTION

E-1 . SCOPE . This appendix lists expendable/durable supplies and materials you will need to operate and maintenance the Small Mobile Water Chiller. This listing is for informational purposes only and is not authority to requisition the listed items. These items are authorized to you by CTA 50-970, Expendable/Durable Items (Except Medical Class V, Repair Parts, and Heraldic Items), or CTA 8-100, Army Medical Department Expendable/Durable Items.

E-2 . EXPLANATION OF COLUMNS

a. Column (1) - Item Number. This number is assigned to the entry in the listing and is referenced in the narrative instructions to identify the material (e.g., "Use cleaning compound, item 5, Appendix D.").

b. Column (2) - Level. This column identifies the lowest level of maintenance that requires the listed item.

C - Operator/crew
O - Unit maintenance
F - Direct support maintenance
H - General support maintenance

c. Column (3) - National Stock Number. This is the National stock number assigned to the item; use it to request or requisition the item.

d. Column (4) - Description. Indicates the Federal item name and, if required, a description to identify the item.

e. Column (5) - Unit of Measure (U/M). Indicates the measure used in performing the actual maintenance function. This measure is expressed by-a two-character alphabetical abbreviation (e.g., in., pr). If the unit of measure differs from the unit of issue, requisition the lowest unit of issue that will satisfy your requirements.

Section II. EXPENDABLE/DURABLE SUPPLIES AND MATERIAL LIST

(1) ITEM NUMBER	(2) LEVEL	(3) NATIONAL STOCK NUMBER	(4) DESCRIPTION	(5) U/M
1	F	5350-00-192-5047	ABRASIVE CLOTH	
2	F		ADHESIVE EPOXY, 13226E1828	
3	O		ADHESIVE-SEALANT, SILICONE, RTV, NONCORROSIVE, MIL-A-46146, TYPE III	OZ
4	O	8040-00-664-4318	ADHESIVE, TY II, MMM-A-1617	QT
5	O		ANTIFREEZE, NONTOXIC PROPYLENE-GLYCOL, PN 13226E1839	GL
6	F		BRAZING ALLOY, SILVER, BCUP-5, QQ-B-645	AR
7	F		BUBBLE, LIQUID TYPE, MIL-L-25567 OR AMS-3159B	
8	C		CALCIUM HYPOCHLORITE POWDER, O-C-114	OZ
9	H		COMPOUND, LAPPING AND GRINDING, A-A-1203	OZ
10	C		DETERGENT, LIQUID	OZ
11	F	6830-00-292-0732	DRY NITROGEN	CY
12	F	3439-00-640-3713	FLUX, BRAZING O-F-499, TY B (AWS TY 3A)	
13	F		MOLD RELEASE (CAGE: 92381) P/N: 3080	OZ
14	C	9130-00-160-1817	GASOLINE, MOGAS, TYPE 1, MIL-G-3056	GL
15	H	9150-00-935-1017	GREASE, AUTOMOTIVE AND ARTILLERY, MIL-G-10924	OZ

Section II. EXPENDABLE/DURABLE SUPPLIES AND MATERIAL LIST (CONT)

(1) ITEM NUMBER	(2) LEVEL	(3) NATIONAL STOCK NUMBER	(4) DESCRIPTION	(5) U/M
16	F	9150-00-058-2286	GREASE, NONTOXIC, GP, MINERAL OIL, CALCIUM SOAP	OZ
17	C	9150-00-186-6705	OIL, LUBRICATING, OEHD, 15W-40, MIL-L-46152	QT
18	F		OIL, LUBRICATING, REFRIGERANT COMPRESSOR, VV-L-825	OZ
19	F	5350-00-264-3485	PAPER, ABRASIVE	SH
20	F	8135-00-130-9754	POLYURETHANE FOAM, FLEXIBLE, MIL-P-26514	OZ
21	O		PRIMER COATING, ZINC CHROMATE, COMP. L. COLOR Y TT-P-1757 OR MIL-P-52192	QT
22	H	9130-00-559-2475	PROPELLANT, KEROSENE, MIL-R-25576	QT
23	O	7920-00-205-1711	RAGS, WIPING	LB
24	F		REFRIGERANT, FLUOROCARBON, TYPE 12, BB-F-1421	LB
25	F	3439-00-244-4540	RODS, WELDING, QQ-R-571	EA
26	F	8040-01-024-6988	SEALING COMPOUND, NON- CURING, POLYSULFIDE BASE, MIL-S-11030	OZ
27	F		SEALING COMPOUND MIL-S-22473, GR A	QT
28	F	8030-00-081-2325	SEALING, LOCKING, AND RETAINING COMPOUNDS, SINGLE COMPONENT, MIL-S-22473, GR HVV	OZ
29	F		SOLDER, SN96, WRAP 3, QQ-S-571, CL3	AR

Section II. EXPENDABLE/DURABLE SUPPLIES AND MATERIAL LIST (CONT)

(1) ITEM NUMBER	(2) LEVEL	(3) NATIONAL STOCK NUMBER	(4) DESCRIPTION	(5) U/M
30	O		SOLDER, ROSIN CORE, SN60, WRAP 2, QQ-S-571	AR
31	F	6850-00-664-5685	SOLVENT, DRY CLEANING	QT
32	O	9905-00-537-8954	TAGS, MARKING	EA
33	O	8030-00-889-3535	TAPE, ANTISEIZE, TETRAFLUOROETHYLENE, MIL-T-27730	RO

APPENDIX F

ILLUSTRATED LIST OF MANUFACTURED ITEMS

F-1 . SCOPE . This appendix includes complete instructions for making items authorized to be manufactured or fabricated at unit maintenance.

A part number index in alphanumeric order is provided for cross-referencing the part number of the item to be manufactured to the figure which covers fabrication criteria.

All bulk materials needed for manufacture of an item are listed by part number or specification number in a tabular list on the illustration.

F-2 . RUBBER STRIP.

PART NUMBER	RUBBER STRIP LENGTHS	LOCATION
13226E1748-23	13.0 INCHES LONG	HOUSING
13226E1748-24	14.5 INCHES LONG	HOUSING
13226E1748-25	27.5 INCHES LONG	HOUSING
13226E1748-28	22.0 INCHES LONG	HOUSING

NOTES

1. Bulk material is MIL-R-6130, TY II, 0.12 inch thick x 0.75 inch wide.
2. Cut rubber strip(s) from bulk to length for each strip needed.

F-3. WIRE.

WIRE NUMBER	WIRE LOCATION		WIRE LENGTH
	FROM	TO	
13226E1793-2	S3-6	GND 1	6.0 INCHES LONG
13226E1809-1	S3-2	E1	12.5 INCHES LONG
13226E1809-2	S3-3	S8-NO	6.0 INCHES LONG
13226E1809-3	S3-2	S3-5	4.0 INCHES LONG
13226E1809-4	S3-2	S2-RED	32.0 INCHES LONG
13226E1809-5	S3-6	S6-2	30.0 INCHES LONG
13226E1809-6	S2-RED	S1-RED	19.0 INCHES LONG
13226E1809-7	S2-BLU	S1-YEL	15.0 INCHES LONG
13226E1809-8	S1-YEL	GND- 2	20.0 INCHES LONG
13226E1809-9	S8-COM	S5-2	59.0 INCHES LONG
13226E1809-10	S5-1	GND- 2	19.0 INCHES LONG
13226E1809-11	S8-COM	S6-1	32.0 INCHES LONG

NOTES

1. Bulk material is MIL-W-5086, TY I, wire size 16 gauge.
2. Cut wire(s) from bulk as needed.

F-4. TUBING, SPRIAL WRAP.

PART NUMBER	LENGTH OF SPRIAL TUBING	LOCATION
13226E1810	67.00 INCHES LONG	WIRING HARNESS

NOTES

1. Bulk material is HT 1/4FR.
2. Cut tubing from bulk as needed.

F-5 . INSULATION, TUBE.

PART NUMBER	LENGTH OF TUBING	LOCATION
13226E1797-1	6.0 INCH LONG	EXPANSION VALVE BULB
13226E1797-2	10.0 INCH LONG	WATER LINE TO EVAPORATOR
13226E1797-3	21.0 INCH LONG	HOSE TO WATER PUMP
13.226E1797-4	5.0 INCH LONG	LINE TO EXPANSION VALVE
13226E1797-5	16.0 INCH LONG	HOSE TO WATER PUMP

NOTES

1. Bulk material is R-180-FS 1-1/8 IN. OD. X 3/8 IN. ID.
2. Cut tubing from bulk as needed.

F-6. TUBE, CLEAR PVC (WATER).

PART NUMMER	LENGTH OF TUBING	LOCATION
13226E1732-2	12.0 INCH LONG	WATER PUMP
13226E1732-3	16.0 INCH LONG	WATER PUMP

NOTES

1. Bulk material is PVTWF075 POLY WIRE, 0.75 ID. X 1.12 OD.
2. Cut tube(s) from bulk as needed.

F-7 . HOSE, FUEL 5/16 IN ID.

PART NUMBER	LENGTH OF TUBING	LOCATION
13226E1714-6	3.00 INCH LONG	FUEL PICK UP ASSEMBLY

NOTES

1. Bulk material is MIL-H-13444, 0.31 IN. ID., 0.562 NOM OD, TY I or II.
2. Cut hose(s) from bulk as needed.

F-8 . HOSE, FUEL 1/4 IN. ID.

PART NUMBER	LENGTH OF HOSE .	LOCATION
13226E1714-11	72.00 INCH LONG	FUEL PICK UP ASSEMBLY
13226E1714-12	3.00 INCH LONG	FUEL PICK UP ASSEMBLY

NOTES

1. Bulk material is MIL-H-13444, 0.25 IN. ID., 0.500 NOM OD, TY I or II.
2. Cut hose(s) from bulk as needed.

F-9 . HOSE, FUEL 1/4 IN. ID.

PART NUMBER	LENGTH OF HOSE	LOCATION
13226E1750-150	30.00 INCH LONG	SKID TO CARBURETOR

NOTES

1. Bulk material is SAE-J517, 0.25 IN. ID.
2. Cut hose(s) from bulk as needed.

F-10 . HOSE, OIL DRAIN.

PART NUMBER	LENGTH OF HOSE	LOCATION
13226E1750-68	15.00 INCH LONG	ENGINE TO SKID

NOTES

1. Bulk material is 1503-8, (Cage 01276).
2. Cut hose from bulk as needed.

INDEX

SUBJECT	PAGE
A	
Additional Authorization List	D-1
Adjustment procedures	
Armature group	4-65
Compressor drivebelt	4-31
Relief valve	4-88
Sparkplugs	4-61
Water pump drivebelt	4-29
Armature group	
Adjustment	4-65
Inspection	4-62
Installation	4-68
Removal	4-67
Replacement	4-62
Testing	4-64
Army Maintenance Management System (TAMMS), The	1-1
Assembly and preparation for use	2-16
Assembly procedures	
Cylinder block assembly	6-1
Thermostatic valve	5-62
Automatic shutdown	2-26
B	
Belts (preventive maintenance)	2-7
Brazing/Debrazing	5-8
Breather assembly	
Inspection	4-101
Installation	4-102
Removal	4-100
Replacement	4-100
C	
Carburetor	
Installation	4-46
Preventive maintenance	4-9
Removal	4-44

I N D E X

SUBJECT	Page
C	
Carrying handles	
Installation	4-97
Removal	4-96
Centrifugal clutch replacement	
Assembly	4-34
Disassembly	4-34
Inspection	4-34
Removal	4-34
Charging Refrigeration System	5-17
Checks and services, operator preventive maintenance	2-3
Checks and services, organizational preventive maintenance	4-8
Common tools and equipment	4-2
Components of end item and basic issue items lists	C-1
Compressor	
Installation	5-46
Removal	5-44
Replacement	5-43
Compressor discharge hose	
Installation	5-29
Removal	5-29
Replacement	5-28
Compressor drivebelt	
Adjustment	4-31
Inspection	4-30
Installation	4-31
Removal	4-31
Replacement	4-30
Compressor suction hose	
Installation	5-28
Removal	5-27
Replacement	5-27
Condenser	
Installation	5-36
Preventive maintenance	2-13
Removal	5-36
Replacement	5-36

INDEX

SUBJECT	Page
Connection 12/24 VOLT INPUT FOR STARTING (Preventive maintenance)	2-12
Cylinder block assembly	
Assembly	5-25
Disassembly	5-24
Replacement	5-23
Repair	6-1
Cylinder heads	
Inspection	5-22
Installation	5-22
Removal	5-21
Replacement	5-20
D	
DA Form 2404, Equipment Inspection and Maintenance Worksheet..	2-5
DA Form 2028, Recommended Changes to Publications and Blank Forms	i
DA Form 2028-2, Recommended Changes to Equipment Technical Publications	i
DA Pam 738-750, The Army Maintenance Management System (TAMMS)	1-1
Data, equipment	1-4
Debrazing	5-9
Decals and instruction plates, operating instructions on	2-29
Description and use of operator' s controls and indicators	2-1
Destruction of Army material to prevent enemy use	1-1
Dimensions, equipment	1-4
Dipstick and tube assembly	
Installation	4-71
Removal	4-70
Replacement	4-70
Disassembly procedures	
Cylinder-block assembly	6-2
Thermostatic valve	5-62

INDEX

SUBJECT	Page
Discharge Refrigerant System	5-5
Drivebelt, compressor	
Adjustment	4-31
Installation	4-31
Removal	4-31
Replacement	4-30
Drivebelt, water pump	
Adjustment	4-29
Installation	4-29
Removal	4-29
Replacement	4-28
E	
Emergency procedure.....	2-31
Engine assembly	
Installation	4-40
Removal	4-38
Testing	4-37
Equipment characteristics capabilities, and features	1-2
Equipment data	1-4
Equipment description and data	1-3
Equipment dimensions	1-4
Equipment weight	1-4
Exhaust system	
Installation	4-36
Preventive maintenance	2-6
Removal	4-35
Replacement	4-35
Expansion valve	
Installation	5-42
Removal	5-41
Replacement	5-39
Testing	5-39
Expendable/durable supplies and materials list	E-1

INDEX

SUBJECT	Page
Evacuation refrigerant system	5-14
Evaporator	
Installation	5-57
Removal	5-55
Replacement	5-54

F

Fan assembly	
Installation	4-32
Preventive maintenance	2-6
Removal	4-32
Replacement	4-32
Filter-drier	
Installation	5-51
Removal	5-50
Replacement	5-50
Flywheel and ring gear assembly	
Assembly	4-76
Disassembly	4-75
Removal	4-74
Replacement	4-73
Foam precleaned	
Cleaning	3-4
Installation	3-5
Preventive maintenance	2-11
Removal	3-4
Service	3-4
Fuel (preventive maintenance)	2-15
Fuel Hose	
Assembly	4-98
Disassembly	4-98
Fuel line	
Preventive maintenance	2-14

G

General information	1-1
General operation	1-6

INDEX

SUBJECT	Page
General support maintenance	6-1
Governor assembly	
Adjustment	4-52
Installation	4-51
Preventive maintenance	2-3
Removal	4-50

H

High pressure switch	
Installation	5-31
Removal	5-30
Replacement	5-30
Testing	4-77
High temperature thermal switch	
Installation	4-87
Removal	4-87
Replacement	4-86
Testing	4-86
Hoses	
Preventive maintenance	2-9
Housing	
Preventive maintenance	2-5
Installation	4-20
Removal	4-20
Replacement	4-21
Replacement	4-20

I

Inspection, unpacking and	4-3
Inspection	
Centrifugal clutch	4-34
Installation procedures	
Carburetor	4-43
Carrying handles	4-97
Compressor	4-34
Compressor	5-46
Compressor cylinder head	5-22
Compressor discharge hose	5-29
Compressor drivebelt	4-31
Compressor suction hose	5-28

INDEX

SUBJECT	Page
Installation procedures (cont)	
Cylinder block assembly	5-23
Cylinder heads	5-22
Dipstick and tube assembly	4-71
Engine assembly	4-40
Exhaust system	4-36
Expansion valve	5-42
Fan assembly	4-32
Filter-drier	5-51
High pressure switch	5-31
High temperature thermal switch	4-87
Housing	4-20
Intake manifold assembly	4-47
Low pressure switch	5-34
Low temperature thermal switch	5-71
Pneumatic timer switch	4-28
Pressure relief valve	5-38
Spark plugs	4-61
Start-run valve assembly	5-68
Starter	4-72
Starter panel assembly	4-58
Starting connection assembly	4-93
Thermostatic valve	5-64
Toggle switch S3	4-26
Trailer mounting kit	5-76
Water pump	4-83
Water pump drivebelt	4-29
Instructions, operating	2-1
Intake manifold assembly	
Installation	4-46
Removal	4-44
L	
Leak-testing refrigeration system	5-12
Leak-testing water system	5-52
List of abbreviations	1-2
Location and description of major components	1-3
Low pressure switch	
Installation	5-34
Removal	5-33
Replacement	5-33
Testing	4-78

INDEX

SUBJECT	Page
Low temperature thermal switch	
Installation	5-71
Removal	5-70
Replacement	5-69
Testing	4-89
Lubrication instructions	4-1

M

Maintenance Allocation Chart	
Explanation of columns.	B-3
Introduction (section I)	B-1
Maintenance Allocation Chart (section II)	B-5
Remarks (section IV)	B-4
Tool and test equipment requirements (section III)	B-4
Maintenance functions	B-1
Maintenance forms, records, and reports	1-1
Maintenance items, illustrated list of	F-1
Maintenance procedures	
Direct Support	4-2
General support	6-1
Operator	3-3
Unit	4-19
Major components, location and description of	1-3
Major systems	1-7
Mounting kit, trailer	
Installation	5-76
Preventive maintenance	2-14
Movement, preparation for	2-28

O

Oil, crankcase	
Preventive maintenance	2-10
Operating instructions on decals and instruction plates	2-29
Operating procedure	2-19

INDEX

SUBJECT	Page
Operation	
General	1-7
In unusual weather	2-31
Principles of	1-6
Under unusual conditions	2-31
Under usual conditons	2-31
Operator maintenance	3-3
Operator preventive maintenance checks and services	2-3
Operator troubleshooting	3-2
Operator's controls and indicators, description and use of . . .	2-1
P	
Paper cartridge	
Installation	3-5
Preventive maintenance	2-11
Removal . . .	3-6
Service . . .	3-5
Pneumatic timer switch	4-27
Preparation for movement	2-28
Preparation for storage or shipment	4-104
Preparation for use	2-16
Preventive Maintenance Checks and Services (PMCS)	
Operator . . .	2-3
Unit	4-8
Principles of operation . . .	1-6
Procedures for Destruction of Equipment to Prevent Enemy Use, TM 750-244-3	1-1
Purging the refrigerant system	5-7
Purging the water system . . .	2-19
Q	
Quality Deficiency Report, SF 368	1-2

INDEX

SUBJECT	Page
R	
Recommended Changes to Equipment Technical Publications, DA Form 2028-2	i
Recommended Changes to Publications and Blank Forms, DA Form 2028	i
Refrigerant Preventive maintenance	2-12
Refrigeration system	
Servicing	5-4
Charging	5-17
Discharging	5-5
Evacuation	5-14
Testing	
Leak-test	5-12
Pressure	5-18
Purging	5-7
Relief valve	
Adjustment	4-88
Assembly	5-60
Disassembly	5-59
Removal procedures	
Brazing	5-10
Carburetor	4-44
Carrying handles	4-34
Compressor	5-44
Compressor discharge hose	5-29
Compressor drivebelt	4-31
Compressor suction hose	5-27
Cylinder block assembly	5-24
Cylinder heads	5-21
Dipstick and tube assembly	4-70
Debrazing	5-9
Engine assembly	4-38
Evaporator	5-55
Exhaust system	4-35
Expansion valve	5-41
Fan assembly	4-32
Filter-drier	5-50
Foam precleaned	3-4
High pressure switch	5-30
High temperature thermal switch	4-87
Housing	4-20
Intake manifold assembly	4-44

INDEX

SUBJECT	Page
Removal procedures (cont)	
Low pressure switch	5-33
Low temperature thermal switch	5-70
Paper cartridge	3-6
Pneumatic timer switch	4-28
Pressure relief valve	5-38
Spark plugs	4-61
Starting connection assembly	4-91
Starter	4-72
Starter panel assembly	4-56
Start-run valve assembly	5-67
Thermostatic valve	5-62
Toggle switch S3	4-26
Water pump	4-80
Water pump drivebelt	4-29
Repair procedures	
Cylinder block assembly	6-1
Fuel hose	4-98
Water hose	4-99
Replacement procedures	
Armature group	4-62
Carburetor	4-44
Centrifugal clutch assembly	4-33
Compressor	5-43
Compressor discharge hose	5-28
Compressor drivebelt	4-30
Compressor suction hose	5-27
Cylinder block	5-21
Cylinder heads	5-20
Dipstick and tube assembly	4-70
Engine assembly	4-36
Evaporator	5-54
Exhaust system	4-35
Expansion valve	5-39
Filter-drier	5-50
Flywheel and ring gear assembly	4-73
High pressure switch	5-30
High temperature thermal switch	4-86
Intake manifold assembly	4-44
Low pressure switch	5-33
Low temperature thermal switch	5-69
Pneumatic timer switch	4-27
Pressure relief valve	5-37
Relief valve	5-58
Sparkplugs	4-60
Starter	4-71
Starter panel assembly	4-54

INDEX

SUBJECT	Page
Replacement procedures	
Starting connector assembly	4-90
Start-run valve assembly	4-62
Thermostatic valve	5-62
Toggle switch S3	4-24
Water pump	4-79
Water pump drivebelt	4-28
Reporting equipment improvement recommendations	1-2
Reporting errors and recommending improvements	i
S	
Scope	1-1
Servicing procedures	
Foam precleaned	3-4
Paper cartridge	3-5
Refrigeration system..	5-4
Service upon receipt	4-2
SF 368, Quality Deficiency Report	1-2
Shipment instructions	4-104
Shutdown, automatic	2-26
Shutdown (standard)	2-27
Skid	
Preventive maintenance	2-13
Repair	4-96
Installation of carrying handle	4-97
Removal of carrying handle	4-96
Spark plugs	
Adjustment	4-61
Installation	4-61
Preventive maintenance	4-13
Removal	4-61
Replacement	4-60
Test	4-61

INDEX

SUBJECT	Page
Start-run valve	
Installation	5-68
Removal	5-67
Replacement	5-66
Starter	
Installation	4-72
Preventive maintenance	4-10
Removal	4-72
Replacement	4-71
Testing	4-71
Starter panel assembly	
Installation	4-58
Removal	4-56
Replacement	4-54
Testing	4-54
Starting connection assembly	
Installation	4-93
Removal	4-91
Replacement	4-90
Storage and shipment instructions	4-104
Strainer, warm in hose (preventive maintenance)	4-14
Support kit	
Repair of fuel hose	4-98
Repair of water hose	4-99
Switches	
High pressure	4-77
Low pressure	4-78
Pneumatic timer	4-24
Systems, major	1-7
System refrigerant	
Brazing/debrazing	5-8
Charging	5-16
Discharge	5-5
Evacuation	5-13
Leak test	5-12
Operational pressure test	5-18
Purging	5-7

T

Table of contents	i
-----------------------------	---

INDEX

SUBJECT	Page
Test procedures	
Armature group	4-64
Engine assembly	4-37
High pressure switch	4-77
High temperature thermal switch	4-86
Low pressure switch	4-78
Low temperature thermal switch	4-89
Refrigeration system	
Leak	5-12
Pressure	5-18
Starter panel assembly	4-54
Wiring harness	4-24
Thermostatic valve	
Installation	5-64
Removal	5-62
Replacement	5-62
Timer, pneumatic, switch	4-27
TM 750-244-3, Destruction of Army Materiel to Prevent Enemy Use	1-1
Toggle switch S3	
Installation	4-26
Removal	4-26
Replacement	4-24
Testing	4-25
Trailer mounting kit	
Installation	5-76
Preventive maintenance	2-14
Repair	4-4
Troubleshooting	
Direct support	5-1
Operator	3-2
Unit	4-14
12/24 VOLT INPUT FOR STARTING connection	
Preventive maintenance	2-12

U

Unit maintenance	4-19
Unit preventive maintenance checks and services	4-8
Unit troubleshooting	4-14
Unpacking	4-3

INDEX

SUBJECT	Page
W	
Water control, START RUN (preventive maintenance)	2-12
Water pump	
Installation	4-83
Preventive maintenance	4-12
Removal	4-80
Replacement	4-79
Water pump drivebelt	
Adjustment	4-29
Inspect	4-29
Installation	4-29
Removal	4-29
Replacement	4-29
Water storage (preventive maintenance)	2-15
Weight, equipment	1-4
Wiring harness	
Preventive maintenance	2-8
Repair	4-23
Test	4-24

By Order of the Secretary of the Army:

Official:

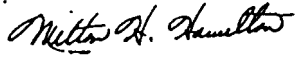

MILTON H. HAMILTON
*Administrative Assistant to the
Secretary of the Army*

GORDON R. SULLIVAN
*General, United States Army
Chief of Staff*

DISTRIBUTION:

To be distributed in accordance with DA Form 12-25E, (qty rqr block no. 2347).

RECOMMENDED CHANGES TO EQUIPMENT TECHNICAL PUBLICATIONS



THEN... JOT DOWN THE DOPE ABOUT IT ON THIS FORM, CAREFULLY TEAR IT OUT, FOLD IT AND DROP IT IN THE MAIL!

SOMETHING WRONG WITH THIS PUBLICATION?

FROM: (PRINT YOUR UNIT'S COMPLETE ADDRESS)
PFC JOHN DOE
COA, 3d ENGINEER BN
FT. LEONARD WOOD, MO 63108
 DATE SENT

PUBLICATION NUMBER TM 10-4130-239-14	PUBLICATION DATE 14 November 1991	PUBLICATION TITLE Small Mobile Water Chiller
---	--------------------------------------	---

BE EXACT... PIN-POINT WHERE IT IS				IN THIS SPACE TELL WHAT IS WRONG AND WHAT SHOULD BE DONE ABOUT IT:
PAGE NO	PARA-GRAPH	FIGURE NO	TABLE NO	
6	2-1 a			In line 6 of paragraph 2-1a the manual states the engine has <u>6</u> cylinders. The engine on my set only has <u>4</u> cylinders. Change the manual to show <u>4</u> cylinders.
B1		4-3		Callout 16 on figure 4-3 is pointing at a <u>bolt</u> . In key to figure 4-3, item 16 is called a <u>shim</u> . Please correct one or the other.
125	line	20		I ordered a gasket, item 19 on figure B-16 by NSN 2 910-00-762-3001. I got a gasket but it doesn't fit. Supply says I got what I ordered, so the NSN is wrong. Please give me a good NSN

PRINTED NAME, GRADE OR TITLE, AND TELEPHONE NUMBER JOHN DOE, PFC (268) 317-7111	SIGN HERE JOHN DOE
---	------------------------------

TEAR ALONG PERFORATED LINE

1 Nov 80

FILL IN YOUR
UNIT'S ADDRESS



FOLD BACK

DEPARTMENT OF THE ARMY



OFFICIAL BUSINESS

COMMANDER
U.S. ARMY TROOP SUPPORT COMMAND
ATTN: AMSTR-MMTS
4300 GOODFELLOW BOULEVARD
ST. LOUIS, MO 63120-1798

TEAR ALONG PERFORATED LINE

RECOMMENDED CHANGES TO EQUIPMENT TECHNICAL PUBLICATIONS



THEN... JOT DOWN THE DOPE ABOUT IT ON THIS FORM. CAREFULLY TEAR IT OUT. FOLD IT AND DROP IT IN THE MAIL!

SOMETHING WRONG WITH THIS PUBLICATION?

FROM: (PRINT YOUR UNIT'S COMPLETE ADDRESS)

DATE SENT

PUBLICATION NUMBER

TM 10-4130-239-14

PUBLICATION DATE

14 November 1991

PUBLICATION TITLE

Small Mobile Water Chiller

BE EXACT PIN-POINT WHERE IT IS

PAGE NO

PARA-GRAPH

FIGURE NO

TABLE NO

IN THIS SPACE TELL WHAT IS WRONG AND WHAT SHOULD BE DONE ABOUT IT:

TEAR ALONG PERFORATED LINE

PRINTED NAME, GRADE OR TITLE, AND TELEPHONE NUMBER

SIGN HERE

DA FORM 2028-2
1 JUL 79

PREVIOUS EDITIONS ARE OBSOLETE.
DRSTS-M Overprint 2, 1 Nov 80.

P.S.--IF YOUR OUTFIT WANTS TO KNOW ABOUT YOUR RECOMMENDATION MAKE A CARBON COPY OF THIS AND GIVE IT TO YOUR HEADQUARTERS.

FILL IN YOUR
UNIT'S ADDRESS



FOLD BACK

DEPARTMENT OF THE ARMY

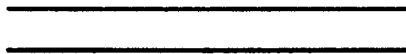

OFFICIAL BUSINESS

COMMANDER
U.S. ARMY TROOP SUPPORT COMMAND
ATTN: AMSTR-MMTS
4300 GOODFELLOW BOULEVARD
ST. LOUIS, MO 63120-1798

TEAR ALONG PERFORATED LINE

RECOMMENDED CHANGES TO EQUIPMENT TECHNICAL PUBLICATIONS

SOMETHING WRONG WITH THIS PUBLICATION?



THEN... JOT DOWN THE DOPE ABOUT IT ON THIS FORM. CAREFULLY TEAR IT OUT. FOLD IT AND DROP IT IN THE MAIL!

FROM: (PRINT YOUR UNIT'S COMPLETE ADDRESS)

DATE SENT

PUBLICATION NUMBER

TM 10-4130-239-14

PUBLICATION DATE

14 November 1991

PUBLICATION TITLE

Small Mobile Water Chiller

BE EXACT . . . PIN-POINT WHERE IT IS

PAGE NO	PARA-GRAPH	FIGURE NO	TABLE NO

IN THIS SPACE TELL WHAT IS WRONG AND WHAT SHOULD BE DONE ABOUT IT:

TEAR ALONG PERFORATED LINE

PRINTED NAME, GRADE OR TITLE, AND TELEPHONE NUMBER

SIGN HERE

DA FORM 2028-2
1 JUL 79

PREVIOUS EDITIONS ARE OBSOLETE.
DRSTS-M Overprint 2, 1 Nov 80.

P.S.--IF YOUR OUTFIT WANTS TO KNOW ABOUT YOUR RECOMMENDATION MAKE A CARBON COPY OF THIS AND GIVE IT TO YOUR HEADQUARTERS.

FILL IN YOUR
UNIT'S ADDRESS



FOLD BACK

DEPARTMENT OF THE ARMY



OFFICIAL BUSINESS

COMMANDER
U.S. ARMY TROOP SUPPORT COMMAND
ATTN: AMSTR-MMTS
4300 GOODFELLOW BOULEVARD
ST. LOUIS, MO 63120-1798

TEAR ALONG PERFORATED LINE

RECOMMENDED CHANGES TO EQUIPMENT TECHNICAL PUBLICATIONS



SOMETHING WRONG WITH THIS PUBLICATION?

THEN... JOT DOWN THE DOPE ABOUT IT ON THIS FORM. CAREFULLY TEAR IT OUT. FOLD IT AND DROP IT IN THE MAIL!

FROM: (PRINT YOUR UNIT'S COMPLETE ADDRESS)

DATE SENT

PUBLICATION NUMBER

TM 10-4130-239-14

PUBLICATION DATE

14 November 1991

PUBLICATION TITLE

Small Mobile Water Chiller

BE EXACT PIN-POINT WHERE IT IS

PAGE
NO

PARA-
GRAPH

FIGURE
NO

TABLE
NO

IN THIS SPACE TELL WHAT IS WRONG
AND WHAT SHOULD BE DONE ABOUT IT:

TEAR ALONG PERFORATED LINE

PRINTED NAME, GRADE OR TITLE, AND TELEPHONE NUMBER

SIGN HERE

DA FORM 2028-2
1 JUL 79

PREVIOUS EDITIONS
ARE OBSOLETE.
DRSTS-M Overprint 2, 1 Nov 88.

P.S.--IF YOUR OUTFIT WANTS TO KNOW ABOUT YOUR
RECOMMENDATION MAKE A CARBON COPY OF THIS
AND GIVE IT TO YOUR HEADQUARTERS.

FILL IN YOUR
UNIT'S ADDRESS



FOLD BACK

DEPARTMENT OF THE ARMY



OFFICIAL BUSINESS

COMMANDER
U.S. ARMY TROOP SUPPORT COMMAND
ATTN: AMSTR-MMTS
4300 GOODFELLOW BOULEVARD
ST. LOUIS, MO 63120-1798

TEAR A LONG PERFORATED LINE

The Metric System and Equivalents

Linear Measure

1 centimeter = 10 millimeters = .39 inch
 1 decimeter = 10 centimeters = 3.94 inches
 1 meter = 10 decimeters = 39.37 inches
 1 dekameter = 10 meters = 32.8 feet
 1 hectometer = 10 dekameters = 328.08 feet
 1 kilometer = 10 hectometers = 3,280.8 feet

Weights

1 centigram = 10 milligrams = .15 grain
 1 decigram = 10 centigrams = 1.54 grains
 1 gram = 10 decigrams = .035 ounce
 1 dekagram = 10 grams = .35 ounce
 1 hectogram = 10 dekagrams = 3.52 ounces
 1 kilogram = 10 hectograms = 2.2 pounds
 1 quintal = 100 kilograms = 220.46 pounds
 1 metric ton = 10 quintals = 1.1 short tons

Liquid Measure

1 centiliter = 10 milliliters = .34 fl. ounce
 1 deciliter = 10 centiliters = 3.38 fl. ounces
 1 liter = 10 deciliters = 33.81 fl. ounces
 1 dekaliter = 10 liters = 2.64 gallons
 1 hectoliter = 10 dekaliters = 26.42 gallons
 1 kiloliter = 10 hectoliters = 264.18 gallons

Square Measure

1 sq. centimeter = 100 sq. millimeters = .155 sq. inch
 1 sq. decimeter = 100 sq. centimeters = 15.5 sq. inches
 1 sq. meter (centare) = 100 sq. decimeters = 10.76 sq. feet
 1 sq. dekameter (are) = 100 sq. meters = 1,076.4 sq. feet
 1 sq. hectometer (hectare) = 100 sq. dekameters = 2.47 acres
 1 sq. kilometer = 100 sq. hectometers = .386 sq. mile -

Cubic Measure

1 cu. centimeter = 1000 cu. millimeters = .06 cu. inch
 1 cu. decimeter = 1000 cu. centimeters = 61.02 cu. inches
 1 cu. meter = 1000 cu. decimeters = 35.31 cu. feet

Approximate Conversion Factors

To change	To	Multiply by	To change	To	Multiply by
inches	centimeters	2.540	ounce-inches	newton-meters	.007062
feet	meters	.305	centimeters	inches	.394
yards	meters	.914	meters	feet	3.280
miles	kilometers	1.609	meters	yards	1.094
square inches	square centimeters	6.451	kilometers	miles	.621
square feet	square meters	.093	square centimeters	square inches	.155
square yards	square meters	.836	square meters	square feet	10.764
square miles	square kilometers	2.590	square meters	square yards	1.196
acres	square hectometers	.405	square kilometers	square miles	.386
cubic feet	cubic meters	.028	square hectometers	acres	2.471
cubic yards	cubic meters	.765	cubic meters	cubic feet	35.315
fluid ounces	milliliters	29.573	cubic meters	cubic yards	1.308
pints	liters	.473	milliliters	fluid ounces	.034
quarts	liters	.946	liters	pints	2.113
gallons	liters	3.785	liters	quarts	1.057
ounces	grams	28.349	liters	gallons	.264
pounds	kilograms	.454	grams	ounces	.035
short tons	metric tons	.907	kilograms	pounds	2.205
pound-feet	newton-meters	1.356	metric tons	short tons	1.102
pound-inches	newton-meters	.11296			

Temperature (Exact)

°F	Fahrenheit temperature	5/9 (after subtracting 32)	Celsius temperature	°C
----	------------------------	----------------------------	---------------------	----

